

## Effect of Entrepreneurship Education on Students' Self-Employment Intentions: The Mediating Role of Perceived Feasibility Self-Employment

<sup>1</sup>Fada, Kodun Abiah,  
<sup>2</sup>Samuel Kaku Msheliza  
& <sup>3</sup>Ekoja Benjamin Ekoja

<sup>1</sup>Department of Business  
Administration, Gombe State  
University

<sup>2</sup>Department of Insurance,  
University of Jos

<sup>3</sup>Department of Accounting and  
Finance, University of Jos

### Abstract

**D**ue to consistent findings in literature, we introduced perceived feasibility of self-employment as an intervening variable to examine its mediating effect between entrepreneurship education and self-employment intentions among students of federal universities in the north-east. The study adopted a quantitative research method with a cross-sectional survey design. A well-structured questionnaire was administered to students across all the federal universities in north-eastern Nigeria where the target population comprised of 77,565 students. A sample size of 398 was drawn using Yamane formula where a response rate of 95.2% was recorded. Data were subjected to cleaning tests and the structural equation model was used to carry out analyses. Findings show that entrepreneurship education has no significant effect on self-employment intentions but it has a significant effect on perceived feasibility of self-employment. Perceived feasibility was found to have no significant effect on self-employment intentions while we fail to reject the null hypothesis which states that Perceived feasibility has no mediating effect between entrepreneurship education and self-employment intentions. The study recommends (among others) that entrepreneurship education syllabuses should be structured with theory and practical aspects that would align students' thoughts and perceptions of self-employment as a feasible career option.

### Keywords:

Entrepreneurship  
education, Perceived  
feasibility, Self-  
employment  
intentions

Corresponding Author:

Fada, Kodun Abiah

### **Background to the Study**

Upon the recognition of the role of entrepreneurship in tackling unemployment through the creation of jobs; and upon the consideration of the power of education in developing attitudes, skills and entrepreneurial mindset, the Federal Government in 2004, through the National Universities Commission (NUC) introduced Entrepreneurship Education, which was aimed at equipping students with entrepreneurial skills, attitudes and competencies in order to be job providers and not job seekers. This supports the viewpoints of Pittaway and Cope (2007); Matlay (2008) and Fada, Aondo and Wummen (2016) who posited that entrepreneurship education refers to the purposeful intervention by an educator in the life of the learner (the student) to survive in the world of business, arguing further that entrepreneurship education develops and stimulates entrepreneurial process, providing all tools (feasibility and desirability as well as confidence in one's self) necessary for self-employment and/or starting up new ventures.

With regards to the effect of entrepreneurship education on students' self-employment intentions, literature has recorded consistent findings. For instance the studies of Muhammad (2013); Ewumi, Oyenuga and Owoyele (2012); Idogho and Ainabor (2011); Sanchez (2011); Souitaris, Zerbinati and Andreas (2007); Lee, Chang and Lim (2005); Wang and Wong (2004); Kolvereid and Moen (1997) (among others) have all reported positive effect of entrepreneurship education on self-employment intentions. These consistencies in findings necessitates the need to find a mechanism that can sustain the consistencies as observed in literature, hence the need to inject a mediating variable in the form of perceived feasibility of self-employment.

### **Statement of the Problem**

To help combat the nation's growing graduate unemployment problem, the National Universities Commission (NUC) in July 2004, organized a workshop on entrepreneurship for Nigerian Universities as a way forward. The NUC's workshop produced a draft curriculum on entrepreneurial studies for Nigerian Universities. Consequently, many Universities have initiated entrepreneurship education programmes (offered mostly in the form of general study courses-GSTs/Gens) in an attempt to reverse graduate unemployment trend by giving the needed training in entrepreneurial skills and theory to enable students to perceived self-employment as a career option. However, statistics have shown that unemployment rate in Nigeria had averaged 9.76% each year from 2006-2016. In 2017, unemployment rate rose from 14.2% to 18.8% with majority of those between the ages of 15-24 years, which is the average age of entry and graduation from university education. While this is a problem which had equally raised many questions as to the impact of entrepreneurship education in our universities, and whether despite the presence of entrepreneurship studies in Nigerian universities, students are yet to consider self-employment as a feasible career option. Consistencies in findings from literature on the impact of entrepreneurship education and self-employment intentions necessitate the need for an intervening variable in the study.

### **Objectives of the Study**

- i. To examine the effect of entrepreneurship education on students' self-employment intentions.
- ii. To examine the effect of entrepreneurship education on perceived feasibility of self-employment.
- iii. To examine the effect of perceived feasibility of self-employment on self-employment intentions
- iv. To examine the mediating effect of perceived feasibility of self-employment on entrepreneurship education and self-employment intentions.

### **Research Questions**

- i. What is the effect of entrepreneurship education on students' self-employment intentions?
- ii. What is the effect of entrepreneurship education on perceived feasibility of self-employment intentions?
- iii. What is the effect of perceived feasibility of self-employment on students' self-employment intentions?
- iv. What is the mediating effect of perceived feasibility of self-employment between entrepreneurship education and self-employment intentions?

### **Hypotheses**

- i. Entrepreneurship education has no significant positive effect on students' self-employment intentions.
- ii. Entrepreneurship education has no significant positive effect on students' perceived feasibility of self-employment intentions.
- iii. Perceived feasibility of self-employment has no significant positive effect on students' self-employment intentions.
- iv. Perceived feasibility of self-employment has no mediating effect between entrepreneurship education and self-employment intentions among students.

### **Literature Review**

This section provides a framework for the study and explored past literature relating to entrepreneurship education, perceived feasibility of self-employment and self-employment intentions. This was proceeded by theoretical and empirical reviews.

### **Conceptual Framework**

The framework tried to establish the effect of entrepreneurship education on self-employment intentions, effect of entrepreneurship education on feasibility of self-employment, effect of perceived feasibility of self-employment on self-employment intentions and the mediating effect of perceived feasibility of self-employment on entrepreneurship education and self-employment intentions. The relationships are reflected on figure 1

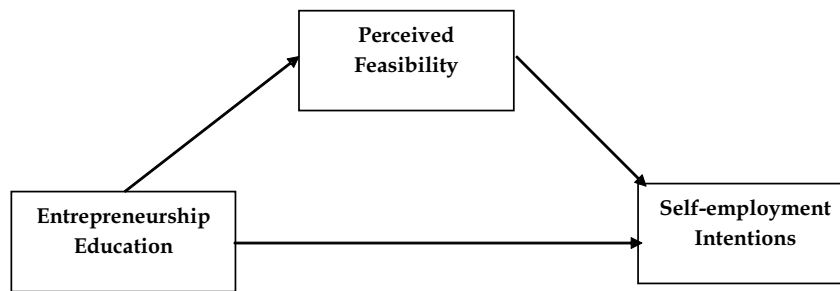

**Figure 1:** Conceptual Framework

### **Concept of Entrepreneurship Education**

Henry, Hill and Leitch (2005) viewed entrepreneurship education as the type of education which assists students to develop positive attitudes, innovation and skills for self-reliance, rather than depending on the government for employment. Solomon (2007:169) argues that “the essence of entrepreneurship is the ability to envision and chart a course for a new business venture by combining information from functional disciplines and from the external environment in the context of the extraordinary uncertainty and ambiguity, which faces a new business venture and self-employment”. This supports the positions of Nabi, Holden and Walmsley (2006); Linan (2008); Fayolle *et al.*, (2006) who argued that entrepreneurship education tries to develop in the participants the intention to perform entrepreneurial behaviours, knowledge and feasibility and desirability of the entrepreneurial activity. This paper aligns its self more with the definition of the concept of entrepreneurship education as given by Henry, Hill and Leitch (2005). The justification for this is that before an individual develops a positive attitude towards self-employment, such individual would have first of all perceived self-employment to a feasible career option.

### **Perceived Feasibility of Self-employment**

Shapero and Sokol, (1982) argued that an individual's perception of feasibility of self-employment is related to the person's perception of available resources such as financial support or knowledge (entrepreneurial education). McGrath and MacMillan (2000) maintained that the belief in the ability of an individual to pursue entrepreneurial action (perceived feasibility), is a function of entrepreneurial education. This paper supports the position of McGrath and MacMillan (2000) who argued that perceived feasibility of self-employment refers to the degree to which becoming self-employed is perceived as a feasible career option.

### **Self-Employment Intention**

Self-employment intention has been defined as the intention to start a new business (Zhao, Seibert, and Hills, 2005), the intention to own a business (Crant, 1996), or the intention to be self-employed (Douglas & Shepherd, 2002). According to Zhao, Hills, and Seibert (2005), the individual decision to choose entrepreneurship as a career is sometimes assumed to depend on personality traits. Intentions predict deliberate behaviours

because behaviour can be planned. Intention is assumed to take hold of emotional factors that influence behaviour and indicate one's effort to try to perform intentional behaviour

## **Theoretical Review**

### **Entrepreneurial Event Theory**

This paper aligns its self with the theory of entrepreneurial event. This is because an entrepreneurial event is primarily a function of perceived feasibility and desirability. While perceived desirability depends on the individual's value or attitude, and social systems in which the person is involved, the former (perceived feasibility) is associated with the abilities of the individual and his competences as well as the likelihood of any support from stake holders. These perceptions according to Shapero and Sokol (1982) often determine if an individual engages in the establishing or starting a company or venturing to becoming a self-employed person. The main focus of this paper however is on the feasibility aspect.

The Entrepreneurial Event theory assumes that an individual usually has the tendency to continue with a current behavior until such a person encounters a displacement event. A displacement is either a negative (push) event or a positive (pull) event. But the underlining fact is that a displacement usually precipitates a change in one's behaviour where the individual or decision maker seeks the optimum opportunity available from a set of other alternatives.

### **Empirical Review**

Literature has largely reported consistent findings on the effect of entrepreneurship education on self-employment intentions among students. In a study, Krueger (1993) found perceived feasibility explaining over half of the variance in self-employment intentions, with feasibility perceptions having the higher explanatory power over the variance. Several researchers have also tested the effect of perceived feasibility of self-employment intentions. For instance, Fitzsimmons and Douglas (2011) found self-employment intentions to be positively related to perceived feasibility employment intentions among students. Other studies that have reported positive effects of entrepreneurship education include Muhammad (2013); Ewumi, Oyenuga and Owoyele (2012); Idogho and Ainabor (2011); Sanchez (2011); Souitaris, Zerbinati and Andreas (2007); Lee, Chang and Lim (2005); Wang and Wong (2004); Kolvereid and Moen (1997). Given these consistencies in findings, it is therefore necessary to establish a mechanism that would sustain the findings in literature, hence the need to examine the mediating effect of perceived feasibility of self-employment.

### **Research Design**

This study adopted the quantitative research method which is inclined to cross-sectional survey. The data was sourced via primary method with structured questionnaire. The questionnaire was administered to students across Federal Universities in the North-Eastern Nigeria. The target population for this study comprises of students from 200L and above who are studying degree courses in Federal Universities with the North-East

which adds up to 77,565. A sample size of 398 was arrived at with the aid of the Yamane formular. The region (North-East) was chosen because study of this nature had never been conducted within the north-east, as such, there is need for this kind of study as it would justify the resources committed to it or provide a model for ensuring that the objective of the program is attained.

### **Variables and Measurement**

In this study, perceived feasibility has been conceptualized to mean the degree to which students in federal universities within the north-east perceive self-employment as a feasible career option (Audet, 2003). The question for perceived feasibility are adapted from Autio, Keeley, Klofsten and Ulfstedt, (1997) and modified to suit the study.

Self-employment intentions referred to entrepreneurial intentions to mean intentions to possess a venture (Basu & Virick, 2008). While entrepreneurship education is a type of education which assists students to develop positive attitudes, innovation and skills for self-reliance, rather than depending on the government for employment (Rudhumbu, Sivotwa, Munyanyiwa & Mutsau (2016). The nature of the questionnaire used for this study was a five-point Likert-scale, ranging from "strongly agree" to "strongly disagree" (5 = 'Strongly Agree', 4 = 'Agree', 3 = 'Undecided', 2 = 'Disagree' and 1 = 'Strongly Disagree') to reflect the agreement of the respondents on the issues raised. A total of 398 questionnaires was administered to the respondents (students) across all federal universities in the north-east. Only a total of 379 were returned giving a response rate of 95.2%.

The data for this study was subjected to data cleaning tests such as out of range, missing values, outliers and normality tests. All the issues relating to the data cleaning were taken care of and the data was certified and used for the final analysis.

### **Method of Analysis**

The structural equation model (SEM) is an extension of the general linear model (GLM) that enables a researcher to test a set of regression equations simultaneously. Structural Equation Modeling (SEM) consists of two types known as the Variance Based Structural Equation Modeling (VB-SEM) and the Covariance Based Structural Equation Modeling (CB-SEM) (Esposito, 2009). While the VB-SEM also known as Partial Least Square Structural Equation Modeling (PLS-SEM) requires small sample size and little or no fitness tests, the CB-SEM requires large sample size of at least 200 and produce many fitness indexes which reflect the appropriateness of a measurement model. This study adopted the Covariance Based Structural Equation Modeling (CB-SEM) given that the sample size for this study is above 200.



**Table 1:** SEM Model fit result

Indices	Benchmark	Result
Root Mean Square of Error Approximation (RMSEA)	< 0.05	Value less than 0.5 is accepted
Normed Fit Index (NFI)	≥0.95	Very close to 1 is a good fit
Tucker-Lewis Index (TLI)	≥0.95	Very close to 1 is a good fit
Comparative Fit Index (CFI)	≥0.95	Very close to 1 is a good fit
Chisq/df	> 2	between 1 and 5

Table 1 shows the indices for testing the model fit and the benchmark.

**Confirmatory Factor Analysis**

Three variables (entrepreneurship education, perceived feasibility and self-employment intentions) where used in this study. The objective is to determine the effect of entrepreneurship education on student self-employment intention with perceived feasibility as the mediating variable. A total of 27 item were initially designed to measure the model. Confirmatory factor based on the highly correlated factor from AMOS led to the dropping of 5 items altogether from the variables.

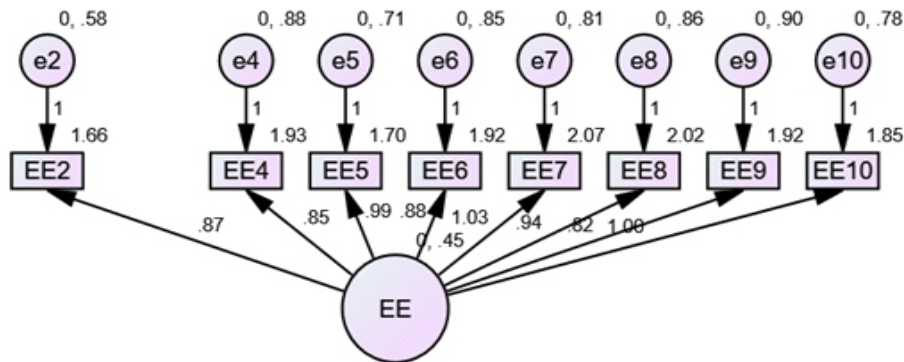

**Figure 1:** Measurement model for Entrepreneurship Education

Figure 1 shows the measurement model for Entrepreneurship education (EE) it revealed that two variables EE1 and EE3 were dropped from entrepreneurship education since the values are below 0.5. The model indicated a good fit because RMSEA is 0.058, CFI is 0.959, TLI is 0.942 and NFI is 0.929.

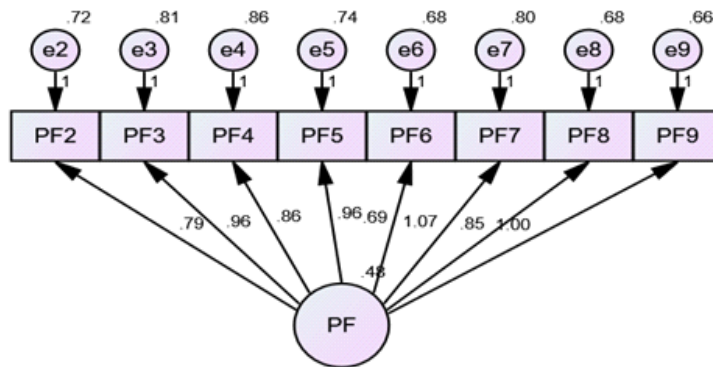

**Figure 2:** Measurement model for Perceived Feasibility (mediating Variable)

Figure 2 shows the measurement model for Perceived Feasibility (mediating Variable) (PF) it revealed that one variable PF1 was dropped from Perceived Feasibility since the value is below 0.5. The model indicated a good fit because RMSEA is 0.051, CFI is 0.970, TLI is 0.958 and NFI is 0.942.

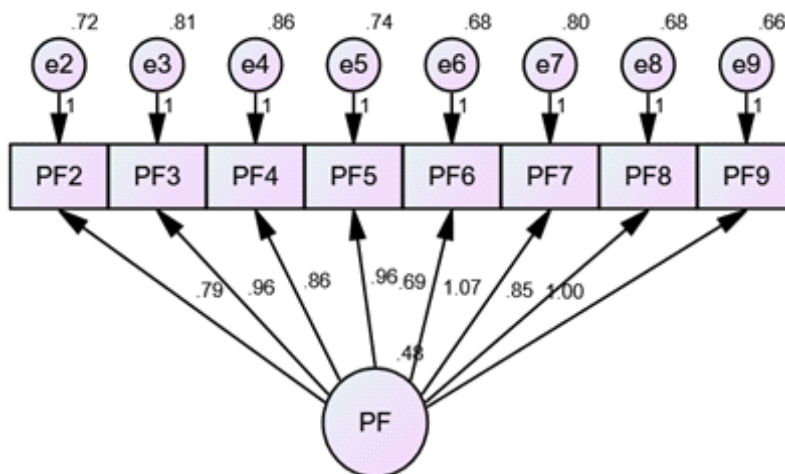

**Figure 3:** Measurement model for Self-employment intentions

Figure 3 shows the measurement model for Self-employment intentions (SEI.) it revealed that two variables SEI1 and SEI2 were dropped from Self-employment intentions since the values are below 0.5. The model indicated a good fit because RMSEA is 0.055, CFI is 0.977, TLI is 0.962 and NFI is 0.959.



**Table 2:** Factor Loading, Convergent validity, AVE and Composite Reliability

S/N	Constructs	Factor Loading
1	<b>Entrepreneurship Education - AVE= 0.57, CR= 0.793</b>	
	EE2	0.606
	EE4	0.517
	EE5	0.619
	EE6	0.537
	EE7	0.607
	EE8	0.560
	EE9	0.501
	EE10	0.603
2	<b>Perceived Feasibility - AVE= 0.58, CR= 0.803</b>	
	PF2	0.541
	PF3	0.592
	PF4	0.539
	PF5	0.607
	PF6	0.501
	PF7	0.638
	PF8	0.580
	PF9	0.649
3	<b>Self-employment Intentions - AVE= 0.59, CR= 0.766</b>	
	SEI3	0.615
	SEI4	0.654
	SEI5	0.533
	SEI6	0.613
	SEI7	0.593
	SEI8	0.555

Table 2 shows the factor loading of all items ranging 0.654 and 0.501. Also the Composite reliability values ranging between 0.766 and 0.803 and AVE ranging between 0.57 and 0.59. This indicated that convergent validity is achieved for the items, the data collection tool is reliable and the AVE was above the threshold of 0.5.

**Table 3:** Discriminant Validity

	ee	pf	sei
ee	0.57		
pf	0.527	0.58	
sei	0.3239	0.324	0.59

Table 3 shows the Discriminant validity result. Discriminant validity was assessed based on the criterion recommended by Fornell and Lacker (1981). The Criterion states that the square root of AVE for each construct must be greater than its correlation with other construct. From table 3, the bold values represented the AVE while unbold represented the correlation. Since the AVE is greater, it confirms discriminant validity.

### Structural Equation Modelling Result

Having satisfied the data cleaning conditions, the validity tests (convergent and discriminant) and the reliability test, the confirmatory analysis is presented in Figure 4. This result indicated the relationship between entrepreneurship education and self-employment intentions, entrepreneurship education and perceived feasibility, perceived feasibility and self-employment intentions. Since perceived feasibility is a mediating variable, the result was split into direct and indirect relationship which the mediating variable was tested to determine if it is an actual mediator.

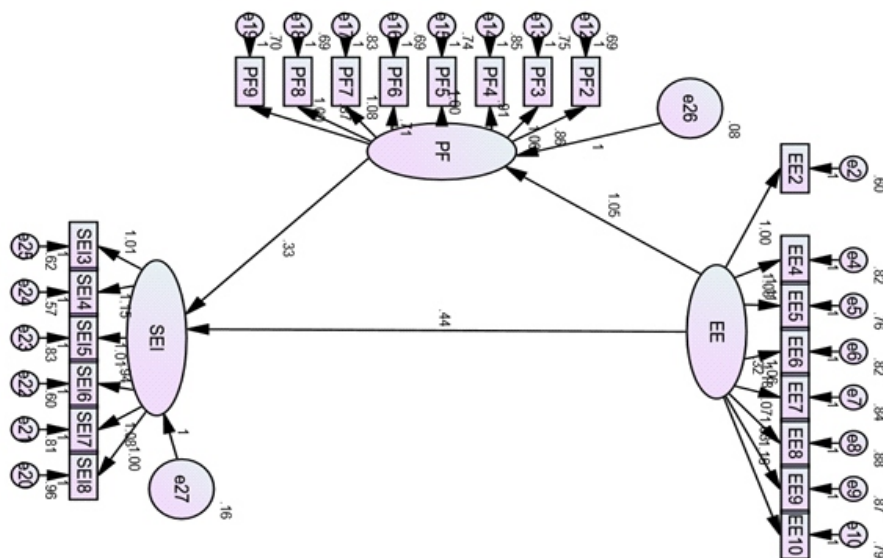

**Figure 4:** SEM result from Model

Figure 4 shows the model fit for final model of the relationship between Entrepreneurship education (EE), Perceived Feasibility (PF) and Self-employment Intention (SEI). The model indicated a good fit because RMSEA is 0.051, CFI is 0.913, TLI is 0.902 and NFI is 0.929.

## Discussion of Findings

**Table 4:** Regression estimates of direct latent constructs

Hypotheses	Construct	Direction	Construct	Standardized Estimate	S.E.	C.R.	P-value	Remark
H <sub>2</sub>	PF	<--	EE	1.054	0.116	9.115	0.000	Supported
H <sub>1</sub>	SEI	<--	EE	0.440	0.228	1.927	0.054	Not supported
H <sub>3</sub>	SEI	<--	PF	0.327	0.194	1.683	0.092	Not supported

**H<sub>01</sub>:** Entrepreneurship education has on significant effect on self-employment intentions

Table 4 shows the result of the relationship between Entrepreneurship education and perceived feasibility. Entrepreneurship education was found to have a positive effect on self-employment intentions with coefficient values of ( $\beta=0.440$ , C.R=1.927, P-value =.054). Therefore, entrepreneurship education has no significant effect on self-employment intentions. This finding contradicts those of Muhammad (2013); Ewumi, Oyenuga and Owoyele (2012); Idogho and Ainabor (2011); Sanchez (2011); Souitaris, Zerbinati and Andreas (2007); Lee, Chang and Lim (2005); Wang and Wong (2004); Kolvereid and Moen (1997) but support that of Bae, Qian, Miao and Fiet (2014).

**H<sub>02</sub>:** Entrepreneurship education has no significant effect on Perceived Feasibility

Table 4 shows the result of the relationship between Entrepreneurship education and Perceived Feasibility. Entrepreneurship education was found to have a positive effect on perceived feasibility of self-employment with coefficient values of ( $\beta=1.054$ , C.R=9.115, P-value =.000). Therefore, entrepreneurship education has a significant effect on perceived feasibility.

**H<sub>03</sub>:** Perceived feasibility has no significant effect on self-employment intentions

Table 4 shows the result of the relationship between Perceived Feasibility and Self-employment intentions. Perceived feasibility was found to have a positive effect on self-employment intentions with coefficient values of ( $\beta=0.327$ , C.R=1.683, P-value =.092). Therefore, Perceived feasibility has no significant effect on self-employment intentions. This is consistent with Douglas (2011) who found self-employment intentions to be positively related to perceived feasibility.

### Testing for Mediating (Indirect-effect) of Perceived Feasibility

Mediation effect can be called as an intervening effect. A mediator is a predictor link in the relationships between two other variables. Normally, a mediator variable can become an exogenous and endogenous variable at same time. By testing for meditational effects, a researcher can explore to examine the influences between these variables. These condition must be met:

1. The independent variable must affect the dependent variable.
2. The mediator must have effect on the dependent variable.

When these conditions for mediation proposed by Baron and Kenny (1986) were examined, it appeared that these conditions not were met. Testing mediation effect using SEM requires significant correlations between independent variable, mediating variable, and the ultimate dependent variable (Hair et al. 2006).

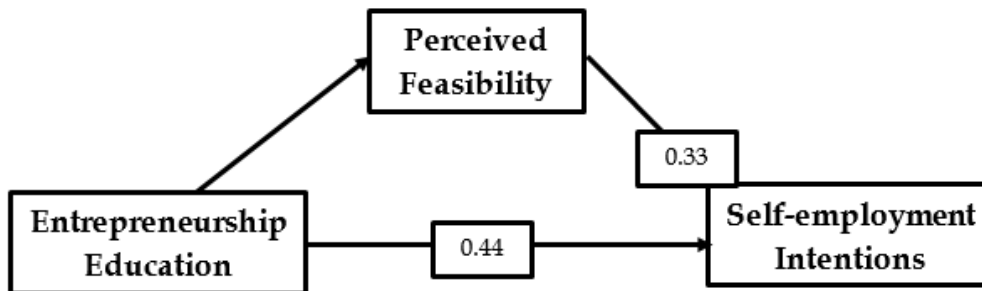

**Figure 5:** Indirect effect

**H<sub>04</sub>:** Perceived feasibility has no mediating effect between entrepreneurship education and self-employment intentions.

From Figure 5 the following assertions are made:

- a. The indirect effect =  $1.05 \times 0.33 = 0.3465$
- b. The direct effect = 0.44
- c. The indirect effect (Entrepreneurship Education) is significant and (Perceived Feasibility) is insignificant

From the above assertions:

- a. Perceived Feasibility variable does not meet the condition to be mediator variable. Since its value  $0.3465 < 0.44$
- b. The model did not indicate full mediation because all the path coefficient presented are not significant (Baron & Kenny, 1986).
- c. The type of mediation here is non-mediation since the indirect effect is insignificant

From the conclusion, we fail to reject the null hypothesis which states that Perceived feasibility has no mediating effect between entrepreneurship education and self-employment intentions.

### Conclusion and Recommendations

Stimulating entrepreneurship requires a good understanding of the reasons leading people to become self-employed. This study ventured to establish the mediating effect of perceived feasibility of self-employment on entrepreneurship education and self-

employment intentions among students of federal universities in north-eastern Nigeria using a structural equation model. The study found that entrepreneurship education has no significant effect on self-employment intentions but it has a significant effect on perceived feasibility of self-employment. Perceived feasibility was found to have no significant effect on self-employment intentions while we fail to reject the null hypothesis which states that Perceived feasibility has no mediating effect between entrepreneurship education and self-employment intentions. We therefore recommend that

- i. Entrepreneurship education in universities across the north-eastern Nigeria should be tailored more towards stimulating students' interest towards self-employment.
- ii. Given that perceived feasibility mean the degree to which self-employment is perceived as a feasible career option, entrepreneurship education syllabuses should structured with theory and practical aspects that would align students thoughts and perceptions of self-employment as a feasible career option.
- iii. The management of Federal Universities in the North-East through the Centre for Entrepreneurship Development should on sessional basis, organize exhibition programs where relevant stakeholders be invited from private and public sectors to share their experiences and to evaluate students entrepreneurial activities. This is so as to enhance the possibility of students' perception of self-employment as a feasible career option.

## References

- Bae, T. J., Qian, S., Miao, C. & Fiet, J.O. (2014). The relationship between entrepreneurship education and entrepreneurial intentions: a meta-analytic review. *Entrepreneurship Theory and Practice*, 38 (2), 217-254.
- Crant, J. M. (1996). The proactive personality scale as a predictor of entrepreneurial intentions. *Journal of Small Business Management*, 34 (3), 42-49.
- Douglas, E. J., & Shepherd, D. A. (2002). Self-employment as a career choice: attitudes, entrepreneurial intentions, and utility maximization. *Entrepreneurship Theory and Practice*, 26 (3), 81-90.
- Ewumi, A. M, Oyenuga, A. O. & Owoyale, J. W. (2012). Entrepreneurship education as panacea for youth unemployment: implication of vocational counseling for sustainable national development. *Journal of Education and Practice*, 3 (14), 73-77.
- Fada, K. A., Aondo, D. C. & Wummen, T. (2016). An assessment of the perception of entrepreneurship education among university undergraduates. *International Journal of Operational Research in Management, Social Sciences and Education*, 2 (1), 28-37.
- Fayolle, A., Gailly, B. & Lassas-Clerc, N. (2006). Assessing the impact of entrepreneurship education programmes: a new methodology. *Journal of European Industrial Training*, 30 (9), 701-720

- Fitzsimmons, J. R. & Douglas, E.J. (2011). Interaction between feasibility and desirability in the formation of entrepreneurial intentions. *Journal of Business Venturing*, 26 (4), 431-440.
- Henry, C., Hill, F. & Leitch, C. (2005). Entrepreneurship education and training: can entrepreneurship be taught? Part I. *Education Training*, 47 (2), 98-111.
- Idogho, P. O. & Ainabor, A. E. (2011). Entrepreneurship education and small scale business management skills development among students of Auchi Polytechnic. *International Journal of Business and Management*, 6 (3), 284-289.
- Kolvereid, L. & Isaksen, E. (2006). New business start-up and subsequent entry into self-employment. *Journal of Business Venturing*, 21 (1), 866-885.
- Krueger, N. F., Reilly, M.D. & Carsrud, A.L. (2000). Competing models of entrepreneurial intentions. *Journal of Business Venturing*, 15 (1), 411-32.
- Krueger, N. (1993). The impact of prior entrepreneurial exposure on perceptions of new venture feasibility and desirability. *Entrepreneurship Theory and Practice*, 18 (1) 23-27.
- Lee, S. M., Chang, D. & Lim, S. B. (2005). Impact of entrepreneurship education: a comparative study of the United States and Korea. *International Entrepreneurship and Management Journal*, 1 (1), 27-43.
- Linan, F. (2008). Skill and value perceptions: how do they affect entrepreneurial intentions? *International Entrepreneurship and Management Journal*, 4 (3), 257-272.
- Marques, C. S., Ferreira, J. J., Gomes, D. N. & Rodrigues, R. G. (2012). Entrepreneurship education: how psychological, demographic and behavioural factors predict the entrepreneurial intention. *Education Training*, 54 (9), 657-672.
- Matlay, H. (2008). The impact of entrepreneurship education on entrepreneurial outcomes. *Journal of Small Business and Enterprise Development*, 15 (2), 382-396.
- McGrath, R.G., & MacMillan, I. C. (2000). *The Entrepreneurial mindset: Strategies for continuously creating opportunity in an age of uncertainty*. Harvard Business Press
- Muhammad, I. H. (2013). Impact of business education and family background on entrepreneurial potential. *Proceedings of 3rd International Conference on Business Management*.
- Nabi, G., Holden, R. & Walmsley, A. (2006). Graduate career-making and business start-up: A literature review. *Education and Training*, 48 (5), 373-385.



- NBS.(2016). <http://www.nigerianstat.gov.ng/> Accessed 7/8/2016.
- Pittaway, L. & Cope, J. (2007). Entrepreneurship education: A systematic review of the evidence. *International Small Business Journal*, 25 (5), 479-510.
- Sanchez, J. C. (2011). University training for entrepreneurial competencies: its impact on intention of venture creation. *International Entrepreneurship Management Journal* 7 (1) 239-254.
- Shapero, A. & Sokol, L. (1982). The social dimensions of entrepreneurship: the displaced, uncomfortable entrepreneur. *Psychology Today*, 1 (1), 83-88.
- Solomon, G. (2007). An examination of entrepreneurship education in the United States. *Journal of Small Business and Enterprise Development*, 14 (2), 168-182.
- Souitaris, V., Zerbinati, S. & Andreas, A. (2007). Do entrepreneurship programmes raise entrepreneurial intention of science and engineering students? The effect of learning, inspiration and resources. *Journal of Business Venturing*, 22 (4), 566-591.
- Tegtmeir, S. (2012). Evaluating introductory lectures in entrepreneurship: empirical implications based on the theory of planned behavior. *International Review of Entrepreneurship*, 10 (1), 178-197.
- Volery, T., Muller, S., Oser, F., Naepflin, C. & Del-Rey, N. (2013). The impact of entrepreneurship education on human capital at upper-secondary level. *Journal of Small Business Management*, 51( 3), 429-446.
- Von Graevenitz, G., Harhoff, D. & Weber, R. (2010). *The effects of entrepreneurship education*. *Journal of Economic Behavior & Organization*, 76 (1), 90-112.
- Wang, C. K., & Wong, P.K. (2004). Entrepreneurial interest of university students in Singapore. *Technovation*, 24 (2), 163-172.
- Zhao, H., Seibert, S. E. & Hills, G. E. (2005). The mediating role of self-efficacy in the development of entrepreneurial intentions. *Journal of Applied Psychology*, 90 (6), 1265-1272.