

## Impact of Facts Devices (STATCOM) on Voltage Improvement and Transmission Losses Reduction on 132 KV Bida Power Transmission Systems Network

<sup>1</sup>Afolabi O. Abioye, <sup>2</sup>Nkeleme V. Obinna, <sup>3</sup>Alimi T. Adekunle & <sup>4</sup>Shallum T. Abraham

<sup>1,2,4</sup>Department of Electrical / Electronic Engineering, Federal Polytechnic Mubi

<sup>3</sup>Department of Electrical / Electronic Engineering, Federal Polytechnic Bida

### Abstract

The Nigeria power system is associated with epileptic supply, poor system stability, high losses, weak bus voltages, line overloads, inappropriate location of generating stations, long transmission lines among others. These affect the overall power quality. Every day, the power transmission and distribution systems face increasing demands for more power, with expecting for better power quality, reliability at lower cost, and as well as low environmental effect. Under these conditions, transmission networks are called upon to operate at high transmission levels, which invariably turn the system to unstable condition. An approach towards solving this problem among others will include placement of Static Synchronous Compensators (STATCOM) optimally by the use of any optimization tool. This paper attempts to solve the problem by using simple heuristic technique which involves randomly placing STATCOM until the best voltage profile and lowest power loss is attained, Bida Power Transmission Network System with 5 buses systems is presented as case study. Simulations carried out confirmed that the STATCOM is capable of minimizing power loss, improve the voltage profile of the network as well as ensure system stability during fault condition on the 132 kV Bida transmission network when compared with the base case (without STATCOM placement).

**Keywords:** *Load Flow Analysis, Facts, Matlab, PSAT, Statcom, Power Loss & Transmission Network.*

*Corresponding Author:* Afolabi O. Abioye,

### **Background to the Study**

Flexible AC Transmission Systems (FACTS) utilize high power semiconductor devices to control the reactive power flow and thus the active power flow of transmission systems so that the ac power can be transmitted across long distances efficiently (Hingoran and L. Gyugy, 1999). The conception of FACTS as a total network control philosophy was first introduced in 1988 by (Hingorani, 1988) from the Electric Power Research Institute (EPRI) in the USA, although power electronic controlled devices had been used in transmission networks for many years before that. Some of the FACTS devices include the STATic synchronous Compensator (STATCOM), Static Var Compensator (SVC), Unified Power Flow Controller (UPFC), Inter-phase Power Flow Controller (IPFC), Static Synchronous Series Controller (SSSC), Convertible Series Compensator (CSC), Thyristor Controlled Series Compensator (TCSC), Thyristor Controlled Phase Shifting Transformer (TCPST), and Super Conducting Magnetic Energy Storage (SMES). The devices may be connected so as to provide either series compensation or shunt compensation depending upon their compensating strategies. It has been proved that shunt FACTS devices give maximum benefit due to their stabilized voltage support when sited at the mid-point of the transmission line ( Ooi and e tal 1997). The STATCOM is a promising technology being extensively used as a state-of-the-art dynamic shunt compensator for reactive power control in transmission and distribution systems [Singh and e tal, 2009 ]. Therefore it has been acknowledged as the next generation reactive power controller in power systems (Venugopal and Jayalaxmi, 2014).

Load flow analysis carried out on power system networks usually involves solving equations that are non-linear in nature using iterative techniques (Gupta, 2000). In a particular power system network there could be dozens or more, depending on the size of the network, of these non-linear equations making it very difficult and extremely time consuming to carry out successful analysis without the use of a computer with a software designed for this particular purpose. An in-exhaustive list of software like MATLAB/SIMULINK (PSAT), SYMPOW, CYME, NEPLAN etc., are designed for this purpose (Nwaobasi and Nkeleme, 2018).

### **Objectives of the Study**

The primary aim of this paper is to investigate the level of stability at the use of STATCOM on the Bida 132kV transmission Network grid system.

This paper therefore focuses on achieving the following objectives;

- i. To evaluate the performance of STATCOM with respect to voltage profiles of the system buses and transmission losses when connected to the transmission network.
- ii. To optimally locate the STATCOM for voltage stability enhancement in Bida 132 kV transmission grid system using heuristic technique.

### **Fact Devices**

Power flow studies gives the steady-state operating condition of the power network, by finding the flow of active and reactive power, voltage magnitudes and phase angles at all nodes of the network. If the power flow study shows voltage magnitudes outside tolerable limit or it is beyond the power carrying capacity of the line, necessary control actions are

taken to regulate it. Flexible AC transmission system device can be defined as a power electronic based system that provide control of one or more AC transmission system parameters to enhance controllability and increase power transfer capability (Piyush, 2012). FACTS technology is simply the collection of controllers applied to regulate and control variables such as impedance, current, voltage and phase angles. FACTS controllers can be divided into four (4) groups: Series Compensators, Shunt Compensators, Series–Shunt Compensators and Series-Series Compensators.

**The benefits of STATCOM to power transmission:**

- i. Stabilized voltages in weak systems
- ii. Reduced transmission losses
- iii. Increased transmission capacity, to reduce, defer or eliminate the need for new lines
- iv. Higher transient stability limit
- v. Increased damping of minor disturbances
- vi. Greater voltage control and stability
- vii. Power oscillation damping

**Modeling of (STATCOM) a Voltage Source Converter (VSC)**

The fundamental component of Voltage Source Converter (VSC) voltage is controlled by varying the DC bus voltage. In order to vary the DC voltage and therefore the reactive power, the VSC voltage angle (alpha) which is normally kept close to zero is temporarily phase shifted. This voltage lag or lead produces a temporary flow of active power which results in an increase or decrease of capacitor voltages (Kowsalya *et al.*, 2009). STATCOM is always located on a load bus. The bus on which STATCOM is being placed is converted from PQ bus to PV bus. Thus STATCOM is considered as a synchronous generator whose real power output is 0 and its voltage is set to 1 p.u.

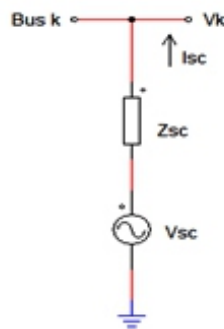

**Figure 1:** Equivalent Circuit of VSC

Figure 1 depicts a typical modeling of an equivalent circuit of a simple Voltage Source Converter (VSC).

The power injected into bus k by the VSC is given by equation (1).

$$P_{SC} = V_{SC} I_{SC} \quad (1)$$

The active power at bus k is given by equation (2).

$$P_k = V_k I_{SC}^* \quad (2)$$

Subject to the constraint

$$V_{SC\min} \leq V_{SC} \leq V_{SC\max} \quad (3)$$

Where,

$V_{SC\min}$  and  $V_{SC\max}$  are the STATCOM minimum and maximum AC voltages.

The switch-mode voltage source converter and its transformer are given by equation (4).

$$V_{SC} = V_K + Z_{SC} I_{SC} \quad (4)$$

$$Z_{SC} = (R_{SC} + X_{SC})^{1/2} \quad (5)$$

$$\text{And } Y_{SC} = \frac{1}{Z_{SC}} \quad (6)$$

$$V_{K(EQUIVALENT)} = \sum_{K=1}^N V_K \quad (7)$$

Where  $V_k$  represents voltage at bus k,  $V_{sc}$  represents the voltage source converter,  $Z_{sc}$  and  $Y_{sc}$  re the coupling transformer impedance and short-circuit admittance respectively.

Voltage magnitude and phase angle using the rectangular co-ordinate representation is given by equations (10) and (11) respectively.

$$V_k = e_k + jf_k \quad (8)$$

$$V_{sc} = e_{sc} + jf_{sc} \quad (9)$$

$$|V_{sc}| = (e_{sc}^2 + f_{sc}^2)^{1/2} \quad (10)$$

$$\delta_{sc} = \tan^{-1} \left( \frac{f_{sc}}{e_{sc}} \right)^{1/2} \quad (11)$$

Where  $|V_{sc}|$  and  $\delta_{sc}$  are the STATCOM voltage magnitude and angle respectively.  
 $e_k$  and  $f_k$  are the real and imaginary parts of the bus voltage respectively  
 $e_{sc}$  and  $f_{sc}$  are the real and imaginary parts of the STATCOM voltage respectively.

### Modeling Single-line diagram of a STATCOM and its control system block diagram

The STATCOM block used in the present study models an Insulated Gate Bipolar Transistor (IGBT) based STATCOM. However, as details of the inverter and harmonics are not represented in transient stability studies, a Gate Turn-Off type of thyristor (GTO) based model can be used.

Figure 2 shows a single-line diagram of the STATCOM and a simplified block diagram of its control system. The STATCOM control system consists of:

- i. A phase-locked loop (PLL) to synchronize the positive-sequence component of the three-phase primary voltage  $V_1$ .
- ii. The direct-axis and quadrature axis components of the a.c. three-phase voltages and currents are labeled as  $V_d$ ,  $V_q$  or  $I_d$ ,  $I_q$  and are computed using the output of the PLL.
- iii. The measurement system for measuring the d-axis and q-axis components of a.c. positive-sequence voltages and currents to be controlled and the d.c. voltage  $V_{dc}$ .
- iv. The regulation loops, namely the a.c. voltage regulator and a d.c. voltage regulator. The outputs of the a.c. voltage regulator and d.c. voltage regulator (namely  $I_{qref}$  and  $I_{dref}$ ) act as reference currents for the current regulator.
- v. An inner current regulation loop consisting of a current regulator, controls the magnitude and phase of the voltage generated by the PWM converter. The output of the PWM is then used as the input control to the voltage source converter (VSC) circuit which regulates the reactive power to the desired quantity that is needed to compensate the transmission bus system where the STATCOM is being placed (Arti, Nitin, & Manoj, 2012).

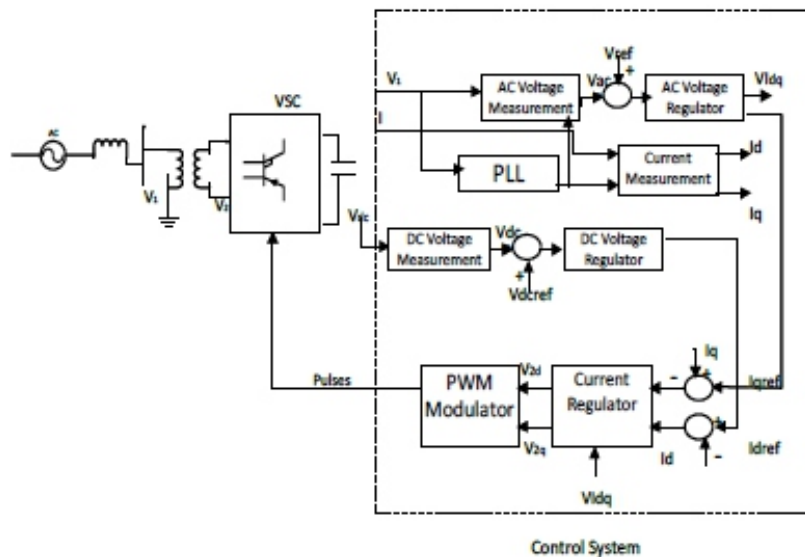

**Figure 2:** Single-line diagram of a STATCOM and its control system block diagram

### Case Study: Bida Transmission Power Network Modeling in PSAT

The Bida power transmission system is used to evaluate the ability of the STATCOM device to control power flow and to enhance transfer capability. The 5-buses system of Bida Transmission network considered was modeled on the PSAT environment to determine the power loss reduction on the network using STATCOM. The simulation of the 132kV Bida transmission network was carried out to determine the power losses of the system as well as the transient analysis with and without STATCOM. Figure 2 shows the one-line diagram of the 132kV Bida transmission network when not connected to the STATCOM to determine the voltage magnitude of the buses. Appendix 1 shows different location of the STATCOM when connected to the Buses.

### Simulation

PSAT 2.1.1.0 - mat version software was used in modeling and simulation of Bida 132 KV transmission Network system. The load system was run with STATCOM and without STATCOM placement. Results of simulations for Voltage profile and the active-reactive power flow on the 5-Bus system carried out for STATCOM unconnected and STATCOM connected on the network presented in Tables 1 and Table 2 respectively.

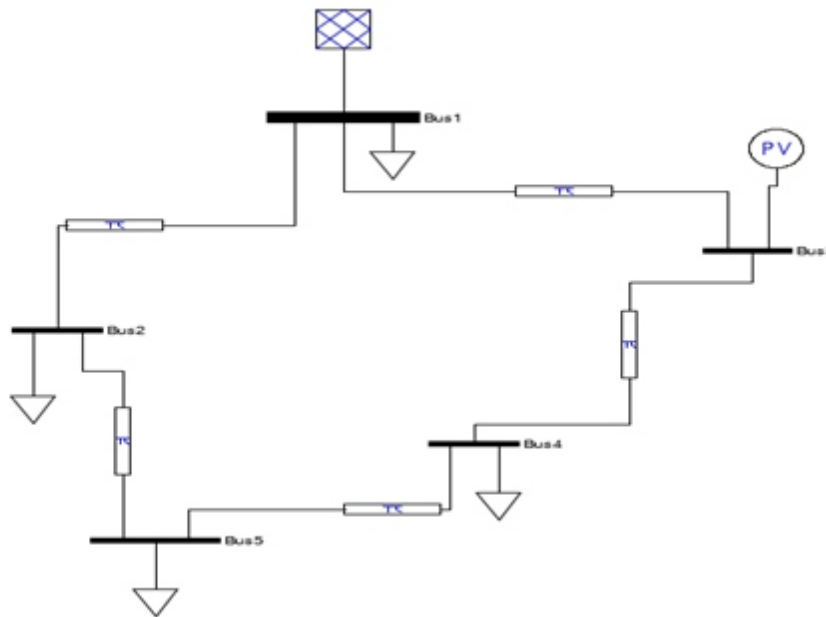

**Figure 3:** Line diagram of the 132kV Bida transmission network

### Result and Discussion

Results of simulations for the voltage profile and the active-reactive power flow on the 5-Bus system carried out for STATCOM unconnected and STATCOM connected on the network are presented in tables 1 and 2.

**Table 1:** Power flow results of the Network.

Bus No	Base Case	Bus Voltage Magnitude (p.u.)			Expected value
		STATCOM at Bus 3	STATCOM at Bus 4	STATCOM at Bus 5	
1	1.02000	1.02000	<b>1.02000</b>	1.02000	1.02000
2	1.02000	1.02000	<b>1.02000</b>	1.02000	1.02000
3	0.93914	1.00000	<b>0.97839</b>	0.95107	1.00000
4	<b>0.92247</b>	0.96052	<b>1.00000</b>	0.94585	1.00000
5	0.96673	0.97953	<b>0.99264</b>	1.00000	1.00000

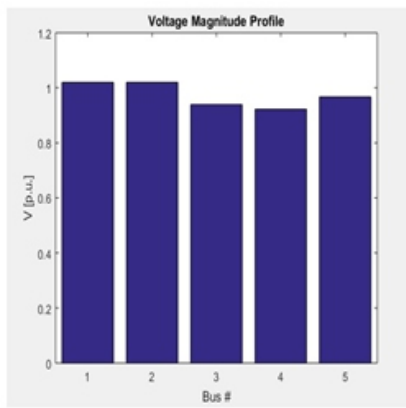

a) Base case

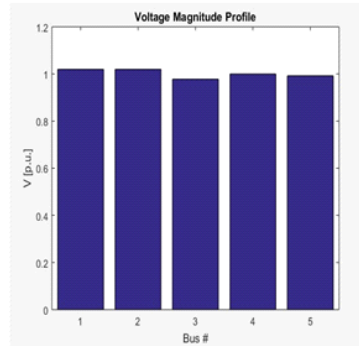

b) STATCOM at bus 3

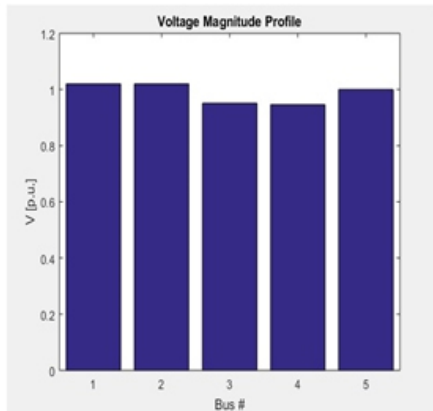

c) STATCOM at bus 4

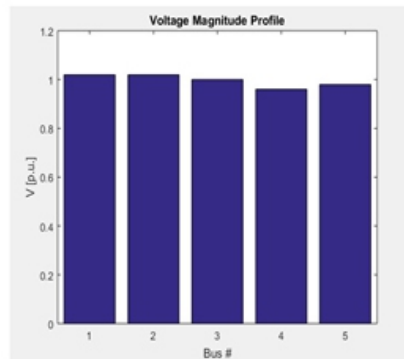

d) STATCOM at bus 5

**Figure 4:** Voltage Profile of the Network System

**Table 2:** Active and Reactive Power Loss Analysis

Bus No	Active Power Loss <b>without</b> STATCOM	Active Power Loss <b>with</b> STATCOM	Reactive Power Loss <b>without</b> STATCOM	Reactive Power Loss <b>with</b> STATCOM
<b>Bus 1</b>	1.51	0.20	-2.53	-7.21
<b>Bus 2</b>	1.16	0.31	-1.76	-5.74
<b>Bus 3</b>	0.45	0.25	-4.14	-4.67
<b>Bus 4</b>	0.54	0.31	-3.67	-4.75
<b>Bus 5</b>	1.23	0.10	0.14	0.02
<b>TOTAL</b>	<b>4.89</b>	<b>1.17</b>	<b>-11.96</b>	<b>-22.35</b>

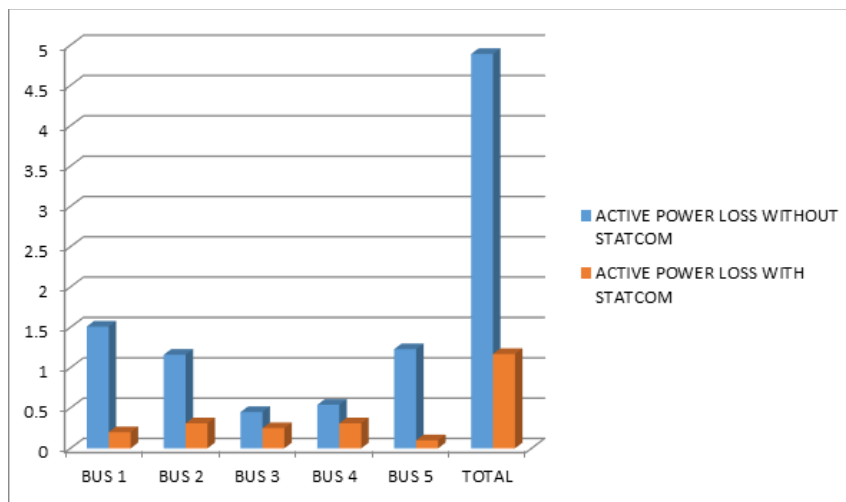

**Figure 5:** Active Power Loss **with** and **without** STATCOM

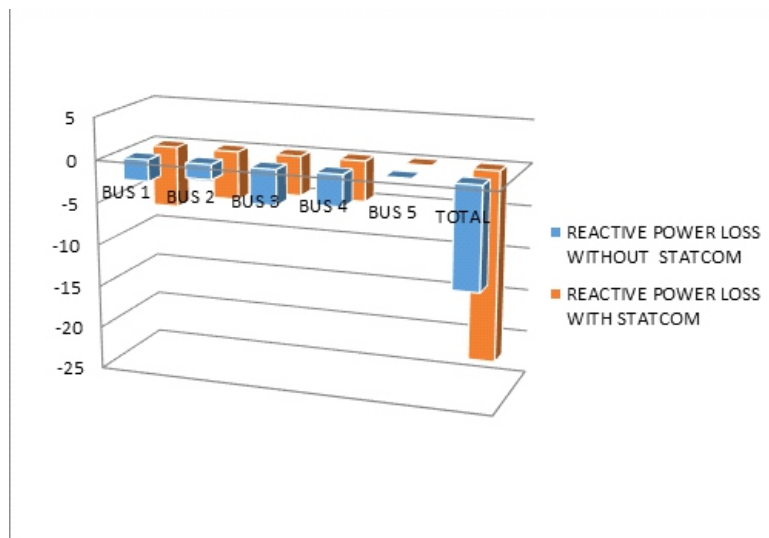

**Figure 6:** Reactive Power Loss **with** and **without** STATCOM



## **Discussion**

### **Voltage Profile**

The major contribution of STATCOM is its stabilizing effect on the voltage that aids immensely maintaining synchronism of the power network. With reference to Table 1, when the network is without STATCOM the amplitude of the bus voltages experienced voltage sag. On the other hand, the STATCOM after being placed optimally produced reactive power compensation and the voltage earlier experienced by the network is overcome and restored to the expected voltage as shown in figure 3. Therefore, it is clear that without FACTS controller (STATCOM in this case), the magnitude of the voltage level reduces with reference to the expected value hence; a decrease in the voltage profile and increased in instability.

### **Power Quality Analysis**

The active power loss measured across the various buses without STATCOM was found to be more as shown in Table 2 compared to when STATCOM is installed in the network. With reference to Table 2, it was found also that the active power loss measured on the various buses of the transmission line decreases due to the reactive power compensation offered as a result of STATCOM connected to the network. The maximum available capability of the transmission line expected for active power transfer from sending end to receiving end was also boosted in this case as depicted in figure 4. To this effect, the power quality of the network was also improved.

## **Conclusions**

The PSAT simulator for steady-state analysis of power flow confirmed the following achievements:

- i. That the 132 kV Bida Transmission power network is weak with voltage limit violations and high power losses.
- ii. That the introduction of STATCOM improved the power quality and bus voltages profile of the entire system.

## **Recommendation**

The study therefore recommends that relevant fast acting devices such as STATCOM are installed as that will help in improving the prevailing challenges in the Bida 132 kV power network, rather than considering the option of building new power network.

## References

- Acha, E., Fuerte-Esquivel, C. R., Ambriz-Perez, H. & Angeles-Camacho, C. (2004). *FACTS modelling and simulation in power networks*. Chichester: John Wiley and Sons.
- Arti, P., Nitin, S., & Manoj, T. (2012). Transfer capability enhancement of transmission line using Static Synchronous Compensator (STATCOM). *International Journal of Advanced Computer Research*, 2(4), 84-87.
- Chow, J. H., & Cheung, A. W. (1992). *A tool box for power system dynamics and control engineering education and research*. New York: Institute of Electrical and Electronic Engineers.
- Enrique, C. R., Fuerte, E., & Ambriz, I. (2004). *FACTS modeling and simulation in power network*. Perez–John Wiley & Sons Ltd .
- Gupta, B. R. (2000). *Power systems analysis and design*. New Delhi: Kataria and Sons
- Hingoran, N. G. & Gyugy, L. (1999). Understanding FACTS, concepts and technology of flexible ac transmission System. India: Wiley- IEEE press, 1 Ed.
- Hingorani, N. G. (1988). “High power electronics and flexible AC transmission system,”. *IEEE Power Engineering review*, 8.
- Kowsalya, M., Ray, K. K., & Kothari, D. P. (2009). Positioning of SVC and STATCOM in a long transmission line. *International Journal of Recent Trends in Engineering*, 2(5), 150-154.
- Nwaobasi, C. & Nkeleme, O. V. (2018). Optimal location of FACTS Devices in Simple interconnected power systems networks using heuristic Techniques, *International Journal of Engineering Technology*, 5(2), 82-90.
- Ooi, B. T., Kazerani, M. & Marceau, R. (1997). Mid-point siting of FACTS devices in transmission lines. *IEEE Trans. Power Del.*, 12(4), 1717-1722.
- Singh, R. P. Bharadwaj, S. K. & Singh, R. K. (2009). Flexible AC transmission system controllers: A state of art. *International Journal of Electronic and Electrical Engineering*, 7(8), 843-850.
- Venugopal, D. & Jayalaxmi, A. (2014). “Congestion management by optimal choice and allocation of FACTS controllers using genetic algorithm” . *International Journal of Soft Computing and Engineering (IJSCE)*, 4(3), 72-76.
- Sen, K. K., (1999), “STATCOM-static synchronous compensator theory, modelling and applications”. *IEEE PES Winter Meeting 2*, 1177-1183.

## Appendix

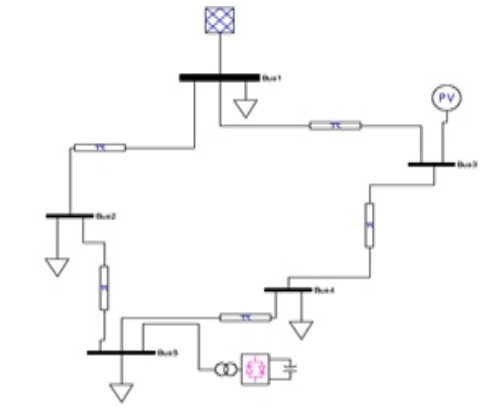

STATCOM at bus 3

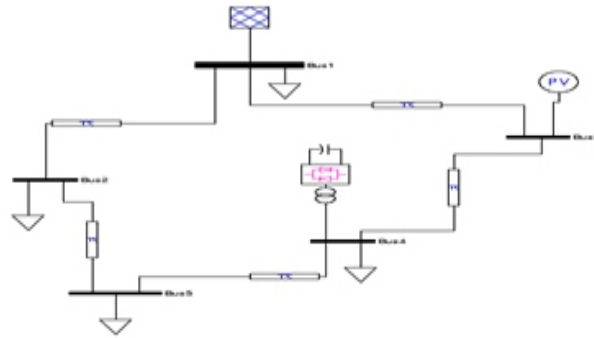

STATCOM at bus 4

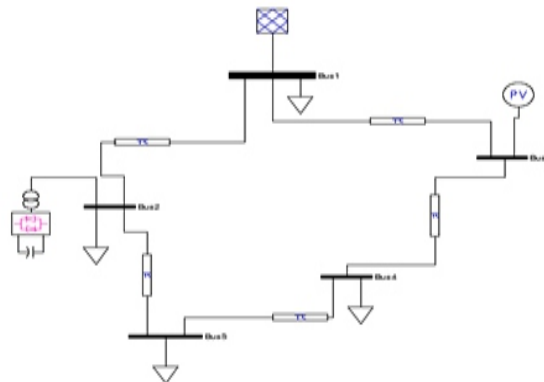

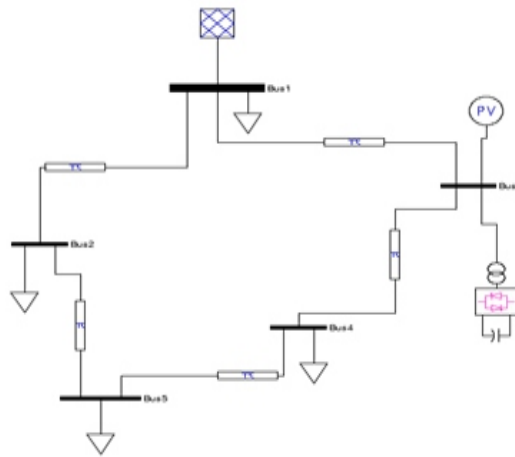

STATCOM at bus 5

**Table 2:** Transmission line data for 132KV Bida Transmission Network

LINE BUS	Bus Voltage Magnitude (p.u.)		
	R	X	B
1 -2	0.01218	<b>0.09163</b>	1.0269
2-5	0.00159	<b>0.01197</b>	0.5366
4-5	0.00480	<b>0.03606</b>	1.6165
1-3	0	<b>0.01932</b>	0
3-4	0.00987	<b>0.07419</b>	0.8315