



## **NATIONAL STRATEGIC CONFERENCE ON STATE SECURITY, INVESTMENT & ECONOMIC MANAGEMENT**

### **THEME**

Challenges of Insecurity, Governance & Economic Development in Nigeria

### **OBJECTIVE**

The National Strategic Conference aims to bring together researchers, scientists and scholar students to exchange and share their experiences, new ideas, and research results about all aspects of Security, Finance, Business, Management, Education, Technology and Economics discuss the practical challenges and evidence-based solutions for Nigeria.

**DATE:** 21st - 22nd November, 2019

**VENUE:** IBB University, Lapai - Niger State, Nigeria

**TIME:** 8:00am

### **CONFERENCE PANEL**

**Dr. Bassey Anam**

Director, IIPRDS - IDPR  
University of Calabar, Calabar

**Dr. Yeldu Yakubu**

Department of Statistics  
Waziri Umaru Federal Polytechnic, Birnin Kebbi

### **CONFERENCE CONTACT**

**Dr. Ella John**

Department of Public Administration  
IBB University, Minna - Niger State (+234) 8036007723

### **SECRETARIAT**

+234 8064426311

+234 8174380445

+234 8060601893

**ISBN: 978-051-759-6**

**Email:** [researchpolicy5@gmail.com](mailto:researchpolicy5@gmail.com)

**Website:** [www.internationalpolicybrief.org](http://www.internationalpolicybrief.org)

© International Institute for Policy Review and Development Strategies | November, 2019

All right reserved under the International Copyright Law. This Book of Abstract, its cover design and content may not be used or produced in any manner without written permission from the International Institute for Policy Review and Development Strategies | IIPRDS.



**WELCOME TO  
IBRAHIM BADAMASI BABANGIDA UNIVERSITY**

**W**elcome to Ibrahim Badamasi Babangida University, Lapai, where “LEARNING FOR SERVICE” is our watch word. Our departments, research centres and units help to foster the intense interdisciplinary approach that shall inspire much of the anticipated outstanding research achievement of the University and make IBBUL a leader in so many fields of human endeavour, both locally and internationally. Our focus is on students, teachers and researchers. We believe it is important that our students realise the full significance of critical thinking and creativity. It is an approach especially suited to confronting many of the hugely complex challenges that face us all today.

IBBUL students will be among the most talented in the nation and the world. They will bring an astounding range of interests and experience to a richly diverse and exciting undergraduate experience. They will be students who engage the examination and shaping of thought with passion and rigor. They will be students who strive to make their own mark on a more knowledgeable, productive, responsible, just and peaceful nation. IBBUL’s faculty will be a centre of great teachers and distinguished scholars, eager to involve undergraduates in their research.

Our curricula combine powerful interdisciplinary vision, in-depth pursuit of a discipline, and extraordinary opportunities for individual exploration and growth. The 21st Century requires rigorous, broad, and imaginative undergraduate training, as well as a profound understanding of what we all share as human beings. I invite you to join us at IBBU Lapai for that is why we believe that the greater we can make IBBU Lapai, the greater its contribution to the well-being of the nation, and the world you and I share.



### **About Us**

**T**he International Institute for Policy Review and Development Strategies (IIPRDS), Nigeria is a member of First Assured Brilliant Intl Limited, incorporated under the Companies & Allied Matters ACT of the Federal Republic of Nigeria. The Institute is a non-partisan organization, independent of government and other bodies. Since incorporated in 2013, IIPRDS has made significant contributions in quality research and international standard publications.

### **Vision/Mission**

To be the world's leading research and publishing Institute on policy review and development strategies. Through independent, collaborative and institutional research, review existing development policies especially in developing economies of the world, research into evidence-based strategies to advance new measures for achieving sustainable development.

### **Research Focus & Publication**

IIPRDS has organized several international research conferences and published proceedings in International multi-disciplinary journals indexed and domiciled in reputable Universities. Special issues are published in the African Development Charter series; a strategic economic and policy blueprint for Africa development.

IIPRDS international journals are published and indexed in 3 directories;

1. Science Publishing Corporation (SPC) Germany
2. International Scientific Research Consortium (ISRC) United Kingdom and
3. International Journals of Advanced Scientific Research (IJASR), Nigeria, Nairobi, Ghana and Tanzania. IJASR are online international open access peer review scholarly journals. Click this links for published Journals:

<http://www.internationalpolicybrief.org/journals>

### **Exchange of Idea Initiative (EII)**

The Institute currently operates an Exchange of Idea Initiative (EII) with other International Research Organizations and Libraries to enhance wider researcher of its journals. With this initiative, Academic Journals are published in various Countries by reputable publishers and research organizations not minding where the conference is held. This dynamism has diversified and improved the quality of the Institute Journals, enhanced International acceptance by indexing research agencies, built confidence in conferees and enhanced their disciplinary relevance.

**We conduct our work with strict independence, objectivity, and non-partisanship.**

**See website: <http://www.internationalpolicybrief.org>**

---

## Contents

	Titles/ Author(s)	Page
1.	<b>Evaluation of International Border Areas on Housing Characteristics in Ogun State, Nigeria</b> <i><sup>1</sup>Ojo Oladimeji Olusola &amp; <sup>2</sup>Oyesile Sunday Oluyinka</i>	1
2.	<b>Resilient Framing Infrastructure for Rapid Rural Development</b> <i><sup>1</sup>Ogunyinka O. I. &amp; <sup>2</sup>Taiwo, M. A.</i>	21
3.	<b>Industrial Relations Practices in Rivers State: The Views of Three Host Communities</b> <i>John Mark</i>	30
4.	<b>Perceived Legislation and E-Commerce Adoption: Evidence from Southwest Nigeria</b> <i><sup>1</sup>Taiwo, Akeem A. <sup>2</sup>Omojaro, Anthony O. &amp; <sup>3</sup>Ademola, Emmanuel A</i>	37
5.	<b>Technological Innovation and Organizational Performance</b> <i><sup>1</sup>Mukail Aremu Akinde &amp; <sup>2</sup>Yusuf Adebola Bako</i>	57
6.	<b>Socio-Cultural and Economic Challenges of Globalization on the Nigerian Social Structure and Way Forward for Sustainable Development</b> <i>Abubakar Aminu Boyi</i>	71
7.	<b>Corporate Governance and Organisational Effectiveness in the Manufacturing Industry</b> <i><sup>1</sup>Bako, Yusuf A. &amp; <sup>2</sup>Olabimtan, Rashidat O.</i>	81
8.	<b>Nature and Pattern of Computer Education Among Orphans in Orphanage Homes Nigeria</b> <i><sup>1</sup>Muhammad Haruna Rasheed, <sup>2</sup>Zuwaira Haruna Rasheed &amp; <sup>3</sup>Muhammad Isah</i>	98
9.	<b>Impact of Information Technology in Some Selected Secondary Schools in Kebbi State</b> <i>Muhammad Haruna Rasheed</i>	114

---

## Contents

Titles/ Author(s)	Page
10. <b>Technological Innovation and Organizational Performance</b> <i><sup>1</sup>Mukai Aremu Akind &amp; <sup>2</sup>Yusuf Adebola Bako</i>	124
11. <b>Participatory Policy Process as Road Map to Economic Development: A Study of Nigeria</b> <i><sup>1</sup>Mutiulla Adebayo Olasupo &amp; <sup>2</sup>Anyanwu, Christianus Izuchukwu</i>	138
12. <b>An Analysis of Selected Editorial Opinions on the Disobedience of Court Orders by the Federal Government of Nigeria</b> <i><sup>1</sup>Abati, Mobolaji Oluwaseun &amp; <sup>2</sup>Onifade, Oluwafemi Sunday</i>	154



-----

*Book of*  
*Proceedings*

---

## EVALUATION OF INTERNATIONAL BORDER AREAS ON HOUSING CHARACTERISTICS IN OGUN STATE, NIGERIA

<sup>1</sup>Ojo Oladimeji Olusola & <sup>2</sup>Oyesile Sunday Oluyinka

Urban and Regional Planning Department,  
Federal Polytechnic Ilaro, Ogun State, Nigeria



### Abstract

Settlements at international border especially those connecting developing countries exhibit unique spatial arrangement due to inhabitants sharing similar socioeconomic and cultural features. However, study linking these factors with housing development patterns at international border is limited or non-available. Hence, this provides crux of the current study. Through application of scientific method, a sample size of 361 was carefully selected among the residents in three towns at Nigeria-Benin Republic international border. Every 5<sup>th</sup> household head was systematically sampled to obtain opinions through well-structured questionnaire instrument. At initial stage of the empirical analysis, the study employed Ripley's K – Function to investigate housing formation pattern in the study area where it was discovered that housing development pattern at Nigeria-Benin Republic international border generally followed a clustered pattern. Socio-economic and cultural factors responsible for such pattern style were examined with the use of Spatial Probit Regression (SPR). From findings, it was discovered that ethnic group, income, occupation, commercial space demand, and education were significant factors as socio-economic and cultural factors that determine housing formation pattern in the study area. Therefore, the study affirmed that socio-economic and cultural factors largely determine the way housing structures are organized in neighbourhoods and, thus, have far reaching implications for sustainable housing development in international borders. Since ethnic group belonging was found as most significant factor through findings, the study recommends that there is need for government to set up joint and consultative forums for educating the predominant ethnic groups in the Nigeria-Benin Republic international border towns.

**Keywords:** Evaluation, Boarder, Housing Characteristics, Development, Ogun State



## **Introduction**

The settlements along Nigeria-Republic of Benin border experience rapid economic activities. Cross border economic activities encourage people to settle at border towns (Taylor, Banda-Thole & Mukuwa 2015 Bonchuk 2013). The assessment of socio-economic characteristics of border residents focused on the household income, marital status, income, household size, education at background and occupation (Gbakeji and Rilwani 2009). Economic growth and increase in population are inseparable elements that foster development. The international border is faced with the reality of high economic activities but shortage in supply of infrastructure facilities. It was attributed to locational problem. The problem of border area in Ogun State related to lack of industries. Therefore, the peripheral area depends on the high number of unemployed due to location of industries in the cities centre (Raubar, 1990).

The border settlements have unique spatial arrangement because the inhabitants share similar socioeconomic activities that prompt physical characteristics. The economic activities of border towns attract the diverse population; it also improves the economic growth. Increase in population creates diversion in socioeconomic activities, the residents are homogenous in nature and economic activities are related to smuggling of goods and services from neighbouring countries. According to Adeyinka (2014), the porosity of border increase smuggling activities and influx of contraband goods in to Nigeria.

The location of settlement shows the socioeconomic approach of the inhabitants; therefore, activities and resources revealed the structure of the settlements. Rudiarto (2018) emphasised that better understanding of the socioeconomic development in an area requires data relating to socioeconomic characteristics and equally be analysed. Border physical environment comprises of many structures and influenced by socioeconomic of the people (Adams & Okoampa, 2011). The issue of socioeconomic development in an area always related to available resources that expand productivity and accomplished by available infrastructure (Mustatea, 2013). This paper presents the analysis of housing and socioeconomic characteristics in international border communities in Ogun state, Nigeria. It is an important consideration towards determining the influence on the wellbeing of the inhabitants and generality of the border area.

## **Literature Review and Theoretical Framework**

Ye & Liu (2013) concluded that socioeconomic development of fringe settlements in the central region of China reconstructed the areas. Housing is very important in life of man, the component of housing requires money, and these determine types and nature of building (Aluko, 2012). The distribution of household income revealed the housing patterns. Socioeconomic status plays vital role on neighbourhood patterns (Kinzig, et.al 2005). Residents with low income may not be able to build house according to the stipulated standard.

The socioeconomic characteristic of border inhabitants undergoes a change that influences housing requirements and formation (Ekop, 2012). Housing development pattern is a complex issue, the complexity of housing development pattern, a pattern of settlement identifies socio cultural characteristics of residents, the pattern can be nuclear or clustered, even dispersed different ethnic group is identified with particular neighbourhood formation. It demonstrates choice of residing by individual (Tompking county comprehensive plan 2015). The infiltration of people into a settlement affects the size and geo-cluster of the area (Ye & Liu 2013). The border towns are strategic areas that influence by migration of people that focus on socioeconomic growth. The pattern found in international border attributed to uncontrolled migration (Pecoud & DeGuchteneine 2006).

### **Socio-Economic Model of Residential Segregation**

The theory of socioeconomic segregation is very vital to the study. The model was formulated by Hawley in 1950 to describe families with similar socio-economic characteristics located in the same neighbourhood. The major indicators in the theory focused on income, tribe and commercial activities. Fossett (2011) studied the pattern of residential segregation with ethnicity and socio-economic level, the pattern of growth and development focus on multiple conditions based on the people of similar characters. Housing composition and residential segregation do not support socio-economic interpretation (Lopez, 1982).

Sharp & Iceland (2013) emphasized the level of inequality in United States income that led to racial segregation in housing. Muhammad, Kasim, Martin, Mohammed, & Adamu (2015) evaluated factors influencing residential segregation as collective socio-economic approach and personal choice of neighbourhood thereby showing that there is a relationship between the choice of residence and occupation. Variations in patterns of land use determine the residential location within an area (Galster & Cutsinger, 2007). Hao (2015) compared residential segregation and physical patterns of housing development. The pattern of intermarriage among immigrant segregated them within the neighbourhood (Tamaru, Stromgren, Vanham & Danzer, 2016). Morais, Cruz & Oliveira (2005) investigated the relationship between residential segregation and social exclusion in Brazilian housing market and concluded that low-income group housing through self-construction results in informal settlements. Land use regulation has impact on segregation of residential areas. The diversity in economic activities of certain tribes relates to changes in the choice of housing and residential location (Garner & Bhattacharyya, 2011). The dynamics and implications of residential segregation in Nairobi rest on the socio-economic differences, inadequate infrastructures and social amenities (Akumu & Olima, 2007; French, 2008). The evolution of neighbourhood contributes to the segregation formation and influence economic composition (Yin, 2009). The residential segregation in Delhi is heterogeneous in nature both in socio-

economic patterns and in differences on setback by Town Planning and Housing Policy (Dupont, 2004).

## **Research Method**

### **Model Specification**

This current study applies socio-economic model of residential segregation as housing development theory to spatial modelling in order to empirically investigate the spatial housing development patterns in international border towns of Ogun State. The essential model of spatial dependence was formulated by Cliff and Ord (1981) and Anselin (1988) allows for spatial dependence in the dependent variable or in the error component. The use of spatial model is informed by the influence of space/location among observations in geography which the model can effectively capture (Anselin, 1988, 1995; Haining, 1990; and Stieve, 2012). There is always a factor responsible for the housing organisation in a particular area.

In this study, the spatial probit model applies to the issue of housing development patterns in international border areas of Ogun State, Nigeria. These areas include Ilara, Idiroko, and Ohunbe. This type of spatial probit model is a less restrictive form of traditional spatial models with the assumption degree of correlation for all cross-sectional units. The studies uses spatial correlation because geographic region is different and demonstrate that reducing restrictions on spatial correlation coefficients can result in significant gains in model power. In addition, the study allows spatial effects to differ between neighbouring and non-neighbouring communities. Thus, this analysis suggests significant differences and reveals that estimates from spatial models can be sensitive to the spatial structure imposed.

$$\mathbf{Log(P)} = \sum_{k=1}^N \sum_{i=1}^T \{Y_i \log[\phi [X_i\beta]] + (1 - Y_i) \log(1 - \phi[X_i\beta])\}$$

Where  $\mathbf{Log(P)}$  = likelihood of housing development pattern in the study area;  $X_i$  = vector of socio-economic and cultural factors as explanatory variables;  $\beta$  = vector of explanatory variables coefficient parameters and  $\phi$  is the cumulative distribution function (c.d.f.) of a standard normal distribution. Setting  $p=0$  or  $\lambda=0$  allows estimation of the spatial lag or spatial error lag model, respectively, and setting  $p = \lambda= 0$  gives the log-likelihood for the standard probit model., traditional probit model analysis was employed as a basis of comparison with the study model results for more robustness check in order to account for an improvement. More importantly, marginal effect analysis would be considered for the interpretation and investigation of the impact of housing development patterns in the study area.

Again, there was an application of a non-parametric technique, Kernel method (famously referred to as *Ripley's K function* -  $K(h)$  or  $K(t)$ ) to predict the kind of housing development pattern in the study area. Kernel method enables analysis of wide variety of patterns (Pisati, 2012; Shawe-Taylor and Cristianini, 2004). The use of  $K(h)$  function for a homogenous Poisson process like housing development pattern in the current research is known as Complete Spatial Randomness (CSR). The simplest use of Ripley's  $K(h)$  function is to test CSR, if the observed events are consistent with a homogeneous poisson process (Smith, 2016). The formula for  $K(h)$  function as suggested by Smith

$$K(h) = \frac{1(\lambda\pi h^2)}{\lambda} = \pi h^2$$

Where  $h$  = distance;  $\lambda$  = the density (number per unit area) of housing structures;  $\pi = \frac{22}{7}$

Distance ( $h$ ) is determined through the application of Euclidean Distance function in ArcGIS software. Euclidean Distance is used regularly as an effective function with same applications (Zhang, Xia, Shortridge, and Wu 2014). According to Zhang et al (2014), if  $q$  (a building) is the nearest point on a geographic element of interest (e.g., housing development pattern) for settlement point  $p$  (town), and the location of  $p$  and  $q$  are  $(p_1, p_2)$  and  $(q_1, q_2)$ , then the distance  $D_{(p, q)}$  is given by:

$$D_{(p, q)} = \sqrt{(p_1 - q_1)^2 + (p_2 - q_2)^2}$$

$\lambda = \frac{N}{A}$ ; where  $N$  = the observed number of points and  $A$  = the area of the study region.

$K$  - Function was applied to test CSR hypothesis. Thus, by standardizing with respect to density approach and rejecting border effects as recommended by Zhang et al (2014) the  $K$ -function reduces simply to area under the CSR Hypothesis. When  $K(h) > 0$ , this implies a mean point counts higher than would be expected under CSR, and hence indicates some degree of clustering at scale  $h$ . Similarly, a value  $K(h) < 0$  implies mean point counts reduces as expected under CSR, and hence indicates some degree of dispersion at scale  $h$ . The Monte Carlo technique was used to test CSR through Ripley's  $K$  function with 95% significance level. Monte Carlo simulation is very important to provide empirical models of uncertainty by which the statistical significance of results can be quantified (Zhang *et al*, 2014; Atkinson, Foody, Gething, Mathur, and Kelly, 2007). Large of the spatial point pattern is undertaken by Monte Carlo simulation because of the complexity of spatial point processes (Zhang *et al*, 2014; Saizen, Maekawa, and Yamamura, 2010).

### Study Areas

Ogun State is situated in the southwest region of Nigeria. It lies approximately between latitude 6.2°N and 7.8°N and longitude 3.0 °E and 5.0°E. Its land area of about 16,762 square

kilometres represent approximately 1.8 per cent of Nigeria's total land mass of 924,000 square kilometres. Ogun State is ranked as the 24th largest of the 36 States in Nigeria in terms of land mass. It is bounded to the west by the Republic of Benin, to the south by Lagos State and a 20 kilometre stretch of the Atlantic Ocean; to the east by Ondo and Osun States; and to the north by Oyo State. Geographically, the State is divided into four regions: *Yewa* to the east, the *Egbas* and *Remos* in the Central core and the *Ijebus* to the east. Ogun State has twenty (20) Local Government Areas (LGAs) but only the local government areas with international boundaries were considered for the purpose of the study. Ogun-Benin Republic international border was selected as a representative international border field because it is a large border area with a moderate growth rate and it has followed the national trends of increasing suburbanization of jobs and people which result in more commuting within border towns (OGRSP, 2015). The study results should, therefore, be fairly typical of large Nigeria border town areas. The three Local Government areas with international boundaries are Ipokia, Imeko Afon and Yewa North local government. In other words, these three local government areas form the research case study. Moreover, a total number of twelve towns are situated along the international border, four (4) from each local government: Ipokia (Idi-iroko, Ogosasa, Ibatefin, Ilashe); Yewa North (Ohunbe, Tobolo, Igbokoto, Ibayun,) and Imeko Afon (Ilara, Idofa, Oke Agbede, Iwoye), Ogun State Regional Plan (2005). Population wise, three towns were purposively selected from each of LGAs. These are Idi-iroko (25,415) Ilara, (11,905) and Ohunbe (2,935) (OSRP, 2005).

Each of the selected towns has the highest population and presence of government activities along the border within their jurisdictions. The existing base map of the settlements was generated through google earth (2019) which shows that Idi-Iroko has 4,111 buildings; Ilara with 1,905 buildings and Ohunbe housing 1,331 buildings. However, a pilot survey was conducted to identify habitable dwelling on the map and to pre-test the study schedule in order to validate the process and research instruments. In addition, pilot survey as a preliminary study was also used to re-examine study variables (Asika,2005; Fawole, Egbokhare, Itiola, Olajide & Olayinka, 2006). Therefore, the available habitable buildings were identified in the process.

The number of habitable dwelling identified in each town are Idi iroko- 3,802; Ilara - 1,480; and Ohunbe- 821 respectively. In other words, the population of the study comprises of 6,103 habitable dwelling in the three selected towns at the Ogun State international border. Moreover, the map below depicts both three local governments and three towns selected for the study, hence, study area map. First arrow signals the caving out of Ogun State map from the country map and second arrow illustrates the derivation map of the three local governments at the international border between Nigeria and Republic of Benin. The map of the study area reveals the three selected towns for the study; Ilara (blue) in Imeko-Afon Local

Government; Ohumbe (purple) in Yewa North Local Government; and Idi-Iroko (yellow) in Ipokia Local Government.

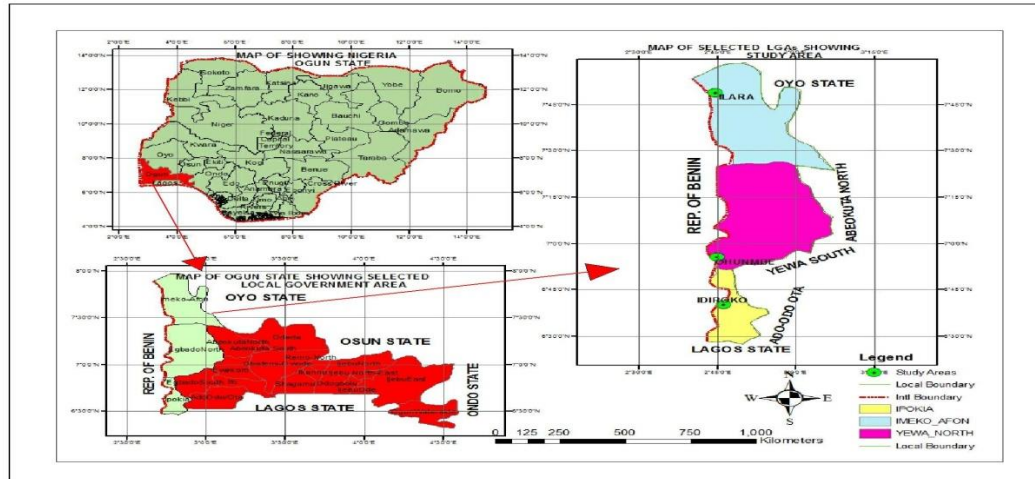

**Figure 1:** Map of Nigeria and Ogun State showing 20 local governments and Subject site, 2017

Source: Survey and Geo-Informatics Department, Federal Polytechnic, Ilaro. Ogun State.

To ensure true representation of the population and enhancing the realization of the set objectives for the study, the systematic random sampling technique was adopted, with first randomly selected and then with every fifth housing unit. The use of this random or probabilistic sampling technique guarantee the study sample to be representative of the whole population (Cochran, 1963; Kish, 1965) because it grants each element in a study area have equal chance of being selected and as such ensures true experiment (Kish, 1965). In order to determine appropriate sample size for this study, the study follows the two way statistical approaches theorised by Cochran (1977) for finite population given the study population of 6,103 habitable dwelling. The sample sizes were calculated by two stages formulae. Firstly, by formula for calculating sample size when the population is infinite this is given as thus;

$$n_0 = \frac{z^2 pq}{e^2} \dots \dots \dots (1)$$

Where,  $n_0$  is the sample size,  $z$  is the selected critical value of desired confidence level,  $p$  is the estimated proportion of an attribute that is present in the population,  $q = 1 - p$  and  $e$  is the desired level of precision (Cochran, 1977).

The study assumes the maximum variability to be 50% ( $p = 0.5$ ) and taking 95% confidence level with  $\pm 5\%$  precision, the calculation for required sample size as follows;

$p = 0.5$  and hence  $q = 1 - 0.5 = 0.5$ ;  $e = 0.05$ ;  $z = 1.96$

$$\text{So, } n_0 = \frac{(1.96)^2(0.5)(0.5)}{(0.05)^2} n_0 = 384$$

Given the fact that  $n_o$  derived is greater than 5% of the population size (6,103). This, however, brings the need to use correction formula to calculate the final sample size. The theorist, Cochran, points out that if the population is finite, then the sample size can be reduced slightly. This is due to the fact that a very large population provides proportionally more information than that of a smaller population (Cochran, 1977). He proposed a correction formula to calculate the final sample size which is given below as;

$$n = \frac{n_o}{1 + \frac{(n_o-1)}{N}} \dots \dots \dots \text{equation 2}$$

Here,  $n_o = 384$  is the sample size derived from equation (1) and  $N = 6,103$  is the population size.

By interpolation, equation (2) becomes;  $n = \frac{384}{1 + \frac{(384-1)}{6,103}} n = 361$

Therefore, in this case the representative sample size for the study is 361. This represents the number of habitable dwellings sampled through questionnaire from a sampling frame of 45 communities (being 20 from Idi-Iroko; 15 from Ilara; and 10 from Ohumbe respectively) by the residents; with housing unit as unit of analysis. Accordingly, the study employed proportional allocation method propagated by Bowley (1926) to determine sample size for each of the three towns under study. The formula is given as;

$$n_i = n \frac{N_i}{N}$$

Where  $n$  represents sample size (361),  $N_i$  represents population size of the  $i^{th}$  town (3,802 buildings in Idi-Iroko; 1,480 in Ilara; and 821 buildings in Ohunbe) and  $N$  represents the population size (6,103). Systematic sampling method was employed where every 5<sup>th</sup> observation was selected after the first observation has been randomly picked. Moreover, to further ensure fair representation of respondents, weights were attached to each selected observation in each community of the study area. The weights are determined by taking the inverse of probability of observation inclusion in the survey process; however, weight derived depends on the relative size of the town.

**Table 1:** Summary of Sample size of Residents by Towns

S/N	Local Govt. Area	Settlements/Towns	Population of buildings	Sample Size of Residents
1	Ipokia	Idi-Iroko	3,802	224
2	Imeko-Afon	Ilara	1,480	87
3	Yewa-North	Ohunbe	821	50
<b>TOTAL</b>			<b>6,103</b>	<b>361</b>

**Source:** Field Survey, 2019

Confirmatory Factor Analysis (CFA), Pearson’s Correlation, Median test and Crosstabs, are the statistical tools used for the analyses as well as the multi-variate analysis involving Structural Equation Model (SEM); Spatial Probit Regression and Traditional Probit regression.

CFA has been used to assess the multidimensionality and the factorial validity of the constructs of the theoretical model (Byrne, 2001; Alsheri, 2013). SEM is used to test theoretical models (Hair *et al.* 2006), so this technique is considered adequate for the investigation carried out by this study. SEM is a fairly new technique for testing models and theories that have already been validated, or for testing models which have a strong theoretical basis. Thus, SEM is help full as a confirmatory technique, with strong mathematical and statistical grounds (MacCallum & Austin, 2000).

**Table 2:** Breakdown Aggregate of Questionnaire Distribution and Retrieval

Town	Total Distributed Questionnaires	Total Retrieved Questionnaire	Retrieval Rate (%)
	Resident	Resident	Resident
Idi-Iroko	224	174	77.7
Ilara	87	62	71.3
Ohunbe	50	38	76.00
<b>Total</b>	<b>361</b>	<b>274</b>	<b>75.9</b>

**Source:** Field Survey, 2019

**Table 3:** Shapiro-Wilk W test for normal data (Socio-economic characteristics - SOECO)

Variable	Obs	W	V	z	Prob>z
sexres	260	0.99692	0.578	-1.277	0.00920
agres	260	0.99665	0.629	-1.081	0.00013
edres	257	0.98216	3.314	2.792	0.00262
ethni	260	0.88697	21.221	7.121	0.00000
incom	258	0.95182	8.984	5.116	0.00000
occup	260	0.97361	4.955	3.731	0.00010
migra	189	0.61794	54.262	9.163	0.00000
hosiz	257	0.96144	7.165	4.588	0.00000
wopro	256	0.69114	57.198	9.426	0.00000
comsd	240	0.99563	0.764	-0.625	0.00401
maloc	255	0.98212	3.301	2.781	0.00271
boloc	259	0.96544	6.466	4.350	0.00001

**Source:** STATA 12 Outputs, 2019



### Socio-Cultural and Economic Construct (SOECO)

The SEM diagram in Figure 2 displays the outcome of the confirmatory factor analysis conducted for socio-cultural and economic factors. From the diagram, some observed variables of SOECO construct were found to be above loadings of 0.5. However, only these factors were considered for further spatial analysis. These factors include education, ethnicity, income, occupation, migration, household size, commercial space demand, and border location. On the other hand, observed variables like sex, age, and work place proximity including market location have loadings below the p value which is 0.5 and therefore were removed. The result is diagrammatically presented as thus.

Figure 2: CFA for SOECO as a Construct

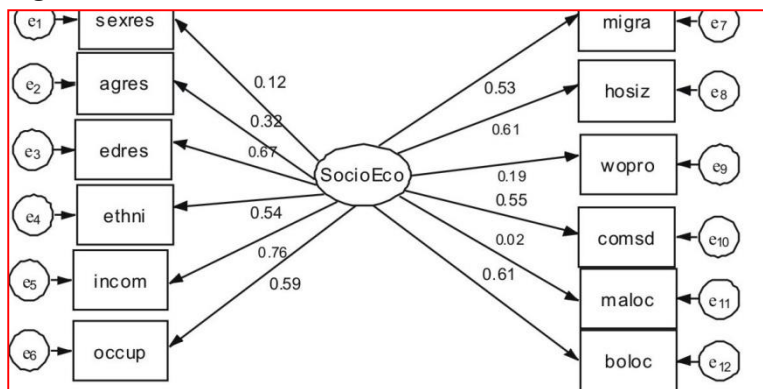

Source: STATA 12 Outputs, 2019

### Housing Formation Pattern Estimation

A Kernel density function, otherwise known as Ripley's K - Function was employed to detect housing formation patterns in the three selected towns and overall study area. Procedurally, Monte Carlo method in STATA application was used to test CSR at 95% confidence level. The approach was employed to simulate randomly generated point patterns and it was assumed that the random number generated is satisfactory. This is consistent with previous study by Besag and Diggle (1977) as observed in Zhang *et al* (2014). Accordingly, if the value for K (h) is statistically greater than zero the structure of the pattern may be determined to be significantly more clustered or otherwise dispersed if value of K (h) is less than zero (Zhang *et al*, 2014); (Besag and Diggle, 1977) . The results of Ripley's K function from STATA 12 software are presented as thus in the following table;

**Table 4:** Ripley’s K function (Monte Carlo Simulations)

Town	Ripley’s K (h)	p - value	Pattern
Idi- Iroko	0.7647	0.0000	Clustered
Ilara	0.8315	0.0000	Clustered
Ohunbe	-0.4292	0.0000	Dispersed
Overall	0.5334	0.0000	Clustered

**Source:** Computation from STATA 12 Monte Carlo Simulations, 2019

In reference to Table 1, a finding revealed that housing formation pattern in Idi-Iroko and Ilara generally followed clustered pattern while housing formation pattern in Ohunbe was predicted as a dispersed pattern. Overall, housing formation patterns in the study area generally followed a clustered pattern. More evidence from thematic maps and Plates of housing formation patterns in the three selected towns further confirmed this finding. Again, this result is consistent with previous study by OGSRP (2005).

### **Spatial Probit Regression (SPR)**

Spatial Probit Regression (SPR) analysis was used to examine the determinants of housing development patterns in the study area. Having established that there is spatial dependency through Ripley’s K - function, this was inferentially analyzed in lieu of residents' socio-cultural and economic characteristics. However, traditional probit regression analysis was initially conducted to show robustness of spatial probit regression. A binary variable taking a value of “1” or “0” was created for housing formation pattern purposely to ensure and facilitate the operation of probit regression. A clustered pattern was assigned a value of “1” while a dispersed pattern was attributed a value of “0”.

There are two important sets of tests a researcher needs to look at before deciding which spatial regression to choose. The first set of tests is between Lagrange Multiplier (LM) which tests for the presence of spatial dependence and Robust LM which tests if either lag or error spatial dependence could be at work while the second set of tests is lag or error. The researcher estimated these two tests through statistical data analysis software application(STATA 12) and the result is presented in the table 5;

**Table 5:** Estimation Results, Spatial *Probit* (Dependent Variable: PATTN)

Variable	Spatial Error Model	Traditional Probit Model
Constant	5.932 (14.24) (0.001)**	3.634 (-7.24) (0.000)**
Edres	0.163 (-0.67) (0.000)**	0.001 (0.24) (0.041)**
Ethni	-0.327 (5.38) (0.000)**	-0.821 (-0.93) (1.375) <sup>ns</sup>
Incom	0.219 (1.35) (0.000)**	0.008 (-0.17) (0.000)**
Occup	0.210 (0.62) (0.003)**	0.010 (0.27) (0.328) <sup>ns</sup>
Migra	-0.077 (4.41) (0.692) <sup>ns</sup>	-0.958 (-0.16) (2.682) <sup>ns</sup>
Hosiz	-0.064 (1.07) (0.075) <sup>ns</sup>	-0.137 (-0.24) (0.642) <sup>ns</sup>
Comsd	0.199 (2.76) (0.000)**	0.015 (0.18) (0.000)**
Boloc	0.051 (-11.69) (0.002)**	0.211 (-16.87) (0.065) <sup>ns</sup>
MF's R <sup>2</sup>	0.592	0.501
Akaike Info Criterion	-391	-371
Schwarz Criterion	-392	-365
No. of Observations	201	205
** p < .05 (significance)	ns = non-significance	

**Source:** Author's Computation from STATA 12 Outputs, 2019

The Table above presents the results of Spatial Probit Regression (SPR) and Traditional Probit Regression (TPR) analyses. In terms of both magnitude and statistical significance, the outcomes reveal that SPR is structurally more robust than TPR. The MF's (McFadden) pseudo R-squared of the Spatial Error Model went up to 0.592. So, it shows that it is a stronger model. Again, the results of model selection criteria in form of Akaike info criterion (AIC) and Schwarz criterion (BIC) also went down and thus indicate that this test is more accurate than

the Traditional Probit Model. This is informed by lowest values of AIC and BIC recorded for preferred model. More so, when the spatial weights are taken into consideration in the model (Spatial Error Model), the spatial regression becomes noticeably stronger in predicting housing development patterns than a traditional probit regression.

Furthermore, the standardized Beta coefficients from the Table reveals that ethnic group as a cultural factor was the greatest predictor of housing development pattern with (Beta = 0.327,  $p = .021$ ), followed by income (Beta = .219,  $p = .000$ ); occupation (Beta = .210,  $p = .003$ ), and commercial space demand (Beta = .199,  $p = .000$ ). However, education (Beta = .163,  $p = .000$ ) and border location (Beta = .051,  $p = .002$ ) have least significant contributions towards housing development patterns in the study area. It is important to note that negative signs of the coefficients were ignored. This practice has been recommended by Pallant (2011) and Ge (2017).

### **Discussion of Result and Implication of Findings**

This current study considered an array of factors to evaluate socio-cultural and economic determinants of housing development patterns in the international border between Nigeria and Benin-Republic in Ogun State. Hitherto, it has been discovered that housing development patterns in the three selected areas generally followed a clustered pattern. In line with this, factors such as sex, education, ethnicity, occupation, income, household size, market location, migration, work place proximity, commercial space demand, and border location were considered as predictors of housing formation patterns. A great number of researchers have considered these factors as predictors of housing development pattern e.g. Abou-Korin (2014); Amao and Ilesanmi(2013); Kasumovic and Jordan(2013); Suditu and Valceanu (2013); Omole (2010); Klapka *et al* (2010); Stasolla and Gamba (2007); Hooke (1996), and among others. However, given the outcome of factor analysis factors like education, ethnicity, occupation, income, migration, household size, and commercial space demand and border location were considered for empirical investigation. From the analysis, the current study discovered that education, ethnicity, occupation, income, commercial space demand and border location were significant factors as socio-cultural and economic variables that determine housing development pattern in the study area. In other words, this finding provides answer to research question that socio-cultural and economic factors determine housing formation pattern in international border towns. This finding illustrates the relevance of Socio-Economic Model of Residential Segregation adopted for the current study and is consistent with Taylor *et al* (2015); Iranmanesh & Imantalab (2014); Abou-korin(2014); Amao & Ilesanmi (2013); Omole (2010);Adams and Ekoampa (2011); and Omole (2010).In terms of unique contributions, the study discovered that ethnic group has largest influence as a socio-cultural factor in predicting housing development patterns in the study area. This is followed by

income of residents, occupation, commercial space demand, education of inhabitants, and border location respectively.

However, part of the finding by the current study revealed contrast result to study by Anabestani (2014). Unlike Anabestani, the current researcher found no significant association between movement of people into regional borders and housing development patterns. This might be connected with border control and management in the study area and possible down to different in studies geographical areas. Meanwhile, the current study strengthens existing literature on socio-cultural and economic factors as determinants of housing development patterns in international borders. This is by taking into account full socio-cultural and economic framework of housing development patterns in the international borders. For instance, social and cultural status of people, employment, and education factors as investigated by Iranmanesh & Imantalab (2014) and Omole (2010) were analysed with other important socio-cultural and economic features like market location, border location and commercial space demand. In addition, the use of a more sensitive specific test for screening or diagnosis (Shapiro-Wilk Test) and a robust Spatial Probit ensured objectively assessed and clinically relevant results. However, the use of just three towns has attendance effect of potential bias but this was adequately controlled for the use of large sample. The three selected towns were the most physically accessible towns in the Nigeria-Benin Republic international border in Ogun State and more importantly these have high population settlements than other remote towns.

### **Conclusion**

Housing is considered an essential necessity for existence of mankind. However, the way such housing is developed and formed is very crucial for policy formulation on housing development by government. It therefore necessitates investigating the spatial distribution of housing development in rural areas most especially international borders through socio-cultural and economic features. From the study, it was discovered that housing development patterns in the study area generally followed a clumsy pattern and are largely determined by residents' socio-cultural and economic factors. These include ethnic group, occupation, income, commercial space demand, and border location. In other words, the reason why housing development patterns in international border towns between Nigeria and Benin-Republic are clustered can be much explained by residents' socio-cultural and economic factors.

### **Recommendations**

Based on the findings of the current study, the researcher recommends that:

- i. There is need for government to set up joint and consultative forums for education of predominant ethnic groups in the international border. Since ethnic group belonging shapes

and influences locals' kind of housing structure, this will go a long way in achieving a befitting housing development pattern in the study area.

- ii. From the research study, inhabitants' occupation determines formation of housing pattern and most of these residents are self-employed. In other words, functioning government economic policies are needed to boost economic activities of people in the country.
- iii. Again, there is need for more government investment in educational development in the areas covered by the study. Private sector involvement is also needed in this aspect.

### References

- Abou-korm A. A. (2014). Small size urban settlements: proposed approach for managing urban future in developing countries of increasing technological capabilities the case of Egypt. *Ainshams Engineering journal* 5 (2) 377 - 390
- Adams, S & Okoampa, E. (2011). Settlement patterns and economic development: Case study of the Twifo-lower Tenkyira district central region of Ghana, *Journal of Arts, Science & Commerce, II* (2) retrieved from, [www.researchersworld.com](http://www.researchersworld.com), 23-08-2017
- Adeyinka, A.M. (2014). Trans-Border movement and trading activities across Nigeria- Benin Republic Border, *Mediterranean Journal of Social Sciences*, 5 (1):415-423
- Akumu, O.A.K & Olima, W.H.A. (2007). The dynamics and implications of residential segregation in Nairobi, *Habitat International* (31): 87-99
- Aluko, O. (2012). Trans - Border communities planning and the problems of arms smuggling in the West African sub-region: The case study of Nigeria - Benin border development, *International Journal of Asian Social Science*, 2 (1).71-80
- Alshehri, M. A. (2012). *Using the UTAUT model to determine factors affecting acceptance and use of e-government services in the Kingdom of Saudi Arabia*, Doctoral Thesis, Griffith University, school of information and communication technology science. retrieved from, <https://www.120.secure.griffith.edu.au>
- Amao, F. L & Ilesanmi, A.O (2013). Housing quality in the urban fringes of Ibadan, Nigeria serial: SB13 Dubai: *National Conference on Advancing the Green Agenda - Technology, Practices and Policies*, Rotterdam (Netherlands) in-house publication paper 8, retrieved from [https://www.irbnet.de/daten/iconda/CIB\\_DC26746.pdf](https://www.irbnet.de/daten/iconda/CIB_DC26746.pdf), 23-8-2017

- Anabestani, A. A. (2014). Analysis of social change effects in rural life on pattern of rural housing: Case study: Binalood County. *Journal of Research & Rural Planning*, 3(5): 57-68.
- Anselin, L. (1988). *Spatial Econometrics: methods and models*. Dordrecht: Kluwer Academic Publishers.
- Atkinson, P. M., Foody, G. M., Gething, P. W., Mathur, A. & Kelly, C.K. (2007). Investigating spatial structure in specific tree species in ancient semi-natural woodland using remote sensing and marked point pattern analysis. *Ecography* 2007, 30, 88-104.
- Besag, J., & Diggle, P.J. (1977). Simple Monte Carlo tests for spatial pattern. *Appl. Stat.* **1977**, 26, 327-333.
- Bevan, A & Conolly, A. (2006). Multiscalar approaches to settlement pattern analysis, a chapter in Lock, G and Molyneaux, B, (eds.) *Confronting Scalene archaeology: Issues of Theory and Practice*, 217---34. New York: Springer.
- Bonchuk, M. O. (2014). Nigeria – Cameroon borderland: Prospects of economic cooperation and integration, *American journal of social issues and Humanities*, 4 (2):99 – 111
- Bowley, A. L. (1926). Measurement of the Precision Attained in Sampling. *Bulletin de l'Institut International de Statistique*, 22, (1), 62-64
- Byrne, B. M. (2001). *Structural Equation Modeling with AMOS: Basic Concepts, Applications, and Programming*. Mahwah, NJ: Lawrence Erlbaum
- Cliff, A. & Ord, J. (1981). *Spatial Processes, Models, and Application*, London: Pion, 1981.
- Cochran, W. G. (1963): *Sampling Techniques*. 2<sup>nd</sup> Ed... New York: John Wiley and sons Inc.
- Cochran, W. G., (1977). *Sampling Techniques*. New York, Wiley: 428.
- Dupont, V. (2004). Socio-spatial differentiation and residential segregation in Delhi: a question of scale? *Geoforum* **35**, 157-175
- Ekop, G. (2012). An assessment of the interrelationships among housing quality variable sets in Calabar metropolis, *Journal of Geography and Regional Planning*, 5 (14):375-380

- Gbakeji, J. O & Rilwani, M. L. (2009). Residents' socio-economic characteristics and the residential mobility process in an urban space: The Example of the Warri Metropolis, Delta State, Nigeria, *Journal Human Ecology*, 27 (1):45-52
- Garner, S & Bhattacharyya, G. (2011). Poverty, Ethnicity and Place, *JRF programme paper: Poverty and ethnicity*, retrieved from, <https://www.jrf.org>. 23-08-2017
- Fossett, M. (2011). Generative models of segregation: investigating model generated patterns of residential segregation by ethnicity and socioeconomic status, *Journal of Math Sociology*, 35 (1-3): 114-145.
- French, K. N. (2008). Patterns and consequences of segregation: An analysis of ethnic residential patterns at two geographic scales (2008). *Theses and Dissertations in Geography*. Paper 2.<http://digitalcommons.unl.edu/geographsthythesis/2> 26/02/2019
- Galster, G & Cutsinger, J. (2007). Racial settlement and metropolitan land use patterns: does sprawl abet black-white segregation, *Urban Geography* 28 (6):516-553.
- Garner, S & Bhattacharyya, G. (2011). Poverty, ethnicity and place, *JRF programme paper: Poverty and ethnicity*, retrieved from, <https://www.jrf.org>. 23-08-2019
- Gbakeji, J. O & Rilwani, M. L. (2009). Residents' Socio-economic characteristics and the residential mobility process in an urban space: The example of the Warri Metropolis, Delta State, Nigeria, *Journal Human Ecology*, 27(1):45-52
- Hair, J., Black, W., Babin, B., Anderson, R., & Tatham, R. (2006). *Multivariate data analysis*(6th ed.). Upper Saddle River, NJ: Pearson Education, Inc.
- Hao, P. (2005). *Residential segregation and the spatial pattern of housing provision in post-reform Chinese Cities: A case study of Shenzhen*, retrieved <https://www.unil.ch>, 26/02/2019
- Haining, R. (1990). *Spatial data analysis in the social and environmental sciences*, Cambridge: Cambridge University Press.
- Hooke D. (1996). Changing settlement patterns and landuse in midland and Southern England in the early medieval and medieval period. *Ruralia 1, pamatky archeologicke, supplementum 5, praha*.retrieved<http://www.ruralia.cz>, 17July, 2017
- Iranmanesh, M & Imantalab, H. (2014). Designing rural housing pattern, *Journal of Applied Sciences Research*, 10 (10): 44-51.



- Jordaan, A. C., Drost, B. E., & Mokgata, M. A. (2004). Land value as a function of distance from the CBD: The case of the Eastern Suburbs of Pretoria. *Sajem* NS 7; No 3
- Kasumovic, M. M & Jordan, L.A. (2013). Social factors driving settlement and relocation decisions in a solitary and aggregative Spider, *the American naturalist*, 182, (4)
- Kinzig, A. P., P. Warren, C. Martin, D. Hope, & M. Katti. (2005). The effects of human socioeconomic status and cultural characteristics on urban patterns of biodiversity. *Ecology and Society* **10** (1): 23. [online]
- Kish, L. (1965). *Survey Sampling*. New York: John Wiley and Sons, Inc. p. 78-94
- Klapka, P. F., Halas, M & Kune, J. (2010). Spatial organization: development structure and approximation of geographical system, *Moravian Geographical Report*, 18(3):53- 65.
- Lopez, M. M. (1982). Housing characteristics and residential segregation: Mexican American in the urban South West, *Housing & Society*. 9(3): 16-28
- MacCallum, R. C., & Austin, J.T. (2000). Applications of structural equation modelling in psychological research, *Annual Review of Psychology*, 51(1), 201-226.
- Muhammad, M. S., Kasim, M., Martin, D., Mohammed, M.I & Adamu, D. (2015). Housing quality in segregated residential neighbourhoods in Bauchi metropolis, *International Journal of Scientific and Research Publications*, 5 (11):432-440
- Morais, M.P., Cruz, B.O & Oliveira, C. (2005). Residential segregation and social exclusion in Brazilian housing markets, Paper to be presented at the *3rd Urban Research Symposium Land Development, Urban Policy and Poverty Reduction*, Brasília, April 4-6,
- Mustăţea, N.M. (2013). Growth poles - an alternative to reduce regional disparities. Case study - Iasi growth pole, *Romanian review of regional studies*, IX (1), 51-60
- Omole K. F. (2010). An assessment of housing condition and socioeconomic life styles of slum dwellers in Akure, Nigeria. *Contemporary Management Research*, 6(4):272-290
- Pisati, M. (2012). *Spatialdata analysis in stata: An overview*. Italian stata user group Meeting. Bologna, September 20-21

- Ravbar, M. (1997). Slovene cities and Suburbs in transformation. *geografski zbornik*, 37, 65-109. Ljubljana. URL: [http://giam.zrc-sazu.si/zbornik/Ravbar\\_37.pdf](http://giam.zrc-sazu.si/zbornik/Ravbar_37.pdf).
- Rudiarto, I., Handayani, W., & Setyono, J. S. (2018). Spatial distribution of socioeconomic characteristics in rural's Java: A Case from Three Different Rural Areas in Central Java. *IOP Conf. Series: Earth and Environmental Science*. Doi: 10.1088/1755-1315/123/1/012024
- Saizen, I. A., Maekawa, & Yamamura, (2010). *Spatial analysis of time-series changes in livestock distribution by detection of local spatial associations in Mongolia*, *Applied Geography*. 30(4): 639-649.
- Sharp, G & Iceland, J. (2013). The residential segregation patterns of whites by socioeconomic status, 2000–2011, *Social Science Res.* 42(4): 1046–1060.
- Stasolla, M & Gamba, P. (2007). Exploiting spatial patterns for informal settlement detection in Arid Environments using optical speeborns Data photogrammetric image analysis, Munica Germany September 19-21 2007
- Stieve, T., (2012). *Moran's I and Spatial Regression*" <http://sites.tufts.edu/./Morans-I-and-Spatial-Regression.docx> Accessed 18 June 2016
- Suditua & Vâlceanu. (2013). Informal Settlements and Squatting In Romania: Socio-Spatial Patterns and Typologies, *Human Geographies – Journal of Studies and Research in Human Geography* 7(2):65–75
- Taylor, T. K., Banda-Thole, Y. & Mwanangombe, H. (2015). Characteristics of House Ownership and Tenancy Status in Informal Settlements in the City of Kitwe in Zambia. *American Journal of Sociological* 5(2): 30-44.
- Tamaru, T., Strömgren, M., Van Ham, M & Danzer, A.M. (2016). Relations Between Residential and Workplace Segregation among Newly Arrived Immigrant Men and Women, *Cities* 59, 131–138
- Tompkins county comprehensive plan 2015, Development patterns 99 – 105.
- Ravbar, M. (1999). General characteristics of boarder areas in Slovenia, *Geographica Slovenica* 31, 11-20.

- Rudiarto, I., Handayani, W., Wijaya, H. B & Insani T.D. (2018). Spatial Distribution of Socioeconomic Characteristics in Rural's Java: A Case from Three Different Rural Areas in Central Java, *IOP Conf. Series: Earth and Environmental Science* 123 (2018) 012024 doi: 10.1088/1755-1315/123/1/0120
- Ye, Y & Liu, X. (2013).. Development of Social Life circumstance of urban fringe settlements in china central region, *Canadian Social Science*, 9 (3):125-129
- Yin, L. (2009). The Dynamics of Residential Segregation in Buffalo: An Agent-based Simulation, *urban study*, 46 (13) & 2749-2770
- Zhang, Z., Xiao, R, Shortridge, A & Wu, J. (2014). Spatial Point Pattern Analysis of Human Settlements and Geographical Associations in Eastern Coastal China- A Case Study. *International Journal Environ. Res. Public Health* (11):2818-2833.

## RESILIENT FRAMING INFRASTRUCTURE FOR RAPID RURAL DEVELOPMENT

<sup>1</sup>Ogunyinka O. I. & <sup>2</sup>Taiwo, M. A.

<sup>1</sup>Department of Computer Engineering,  
Federal Polytechnic, Ilaro, Ogun State

<sup>2</sup>Department of Electrical/Electronic Engineering,  
The Federal Polytechnic, Ilaro, Ogun State



### Abstract

*The major occupation of rural settlers is farming. However, due to the primitive farming tools and irrigation methods, farm produce can hardly feed the rural areas not to talk of generating income for the needed development. Besides, the lack of development and sustenance had contributed greatly to the rural to urban migration which is gradually making the rural areas desolate. This paper presents a microcontroller-based Client/Server Irrigation System for very large scale farming. The client terminals are positioned strategically within the farm to monitor the soil moisture and send its readings to the Server terminal through an RF radio. The server terminal compares the received readings with the set threshold to determine if irrigation is required or not. For irrigation to occur, the Server terminal activates the water pump and opens the corresponding water valve that connects to the farm area monitored by the client terminal. This irrigation system is resilient as it adapts to varying weather condition since it will be positioned on the farm. It also guarantees the cultivation of very large farm areas which will ensure rapid rural development through increased income from the sales of the farm produce. Besides, this system conserves the use of scarce water resources.*

**Keywords:** *Resilient, Irrigation System, Client/Server, Rural Development and Soil Moisture.*

### Introduction

Rural dwellers are predominately farmers. The development of their society is anchored on the improvement of their wellbeing through their core competence which is farming (Hossain, 2004). With only 40% out of the available 75% arable land in Nigeria been cultivated; there exists room for farming especially within the rural areas (Ogunyinka & Olorunsogbon, 2016). However, for the development of the rural areas, there is a need for sustainable agricultural development as described by a 2012 report of European Commission (EU) on agriculture development. In the report, sustainable agriculture was described as the improvement of

quality of life in the rural areas, ensuring food supply for the present and future generation and generating sufficient income or wealth for the farmers.

Achieving this goal is beyond the primitive farming practice of the rural dwellers which involves the use of small farming tools and irrigation techniques. Rather, this calls for the development of resilient farming infrastructure that can adapt to weather conditions, conserve water, ensures the cultivation of the available vast arable land and guarantees an all-year farming practice.

### **Related Works**

Irrigation systems researches were aimed at ensuring optimum crop yield and adequate water conservation. The Smart Irrigation Decision Support (SIDS) developed by Hamouda, 2017 uses Wireless Sensor Networks (WSNs) to monitor the crop parameters by attaching Sensor Nodes (SN) to each crop to monitor its soil moisture and temperature. The final output actuators for a proper agricultural activity is activated once the sensed information reaches the server via the sink node that aggregates information passed from SN to SN using the multi-hop communication technique. In a greenhouse irrigation system using WSNs, Harun et.al, 2015 uses sensors to get pH, temperature, humidity and moisture readings and sent reading to a remote server for proper monitoring and analysis. The system triggers the pump and valves for the irrigation process once the moisture data reaches a set threshold value of Volumetric Water Content (VWC).

Programmable Logic Controller (PLC), PUNDE et.al, 2017 used a dry sensor (transistor and metal electrode) and temperature sensor (LM35) to irrigate in a poly house and greenhouse farming. The dry sensor monitors the moisture and water level ratio and sends a signal to the PLC to ON/OFF water motor and sprinkler motor. Similarly, the temperature sensor maintains a temperature value by turning ON/OFF the dc fan based on the signal received by the PLC following the set temperature range. Using IOS/ Android application, Isik et.al, 2017 to monitor and control the irrigation a PLC based irrigation system was designed. The application is used to monitor and control via mobile devices. In a drip irrigation setup, the microcontroller was used to design an irrigation system that monitors the soil moisture and temperature. Once the desired moisture level is reached the sensor signals the microcontroller to turn OFF relays which controls the valve. This irrigation system conserves water by dispersing the required water based on the preset moisture level thresholds (Ashok & Ashok, 2010).

### **Irrigation System Design**

The Client/Server irrigation system is a network of two client terminals located within the farm, connected to a server terminal via an RF Radio. For proper scheduling of the irrigation

process, an Arduino microcontroller was used as the heart of the design to coordinate the affairs of the terminal. To communicate with the Arduino, C programming language was used. Fig 1 below shows the design layout of the irrigation system while fig. 2 shows the irrigation system equipment needed for farm setup.

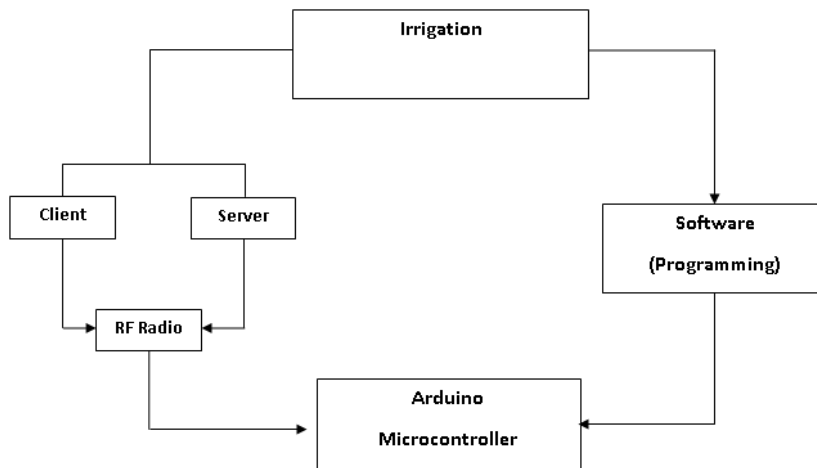

**Fig 1:** Irrigation System Overview

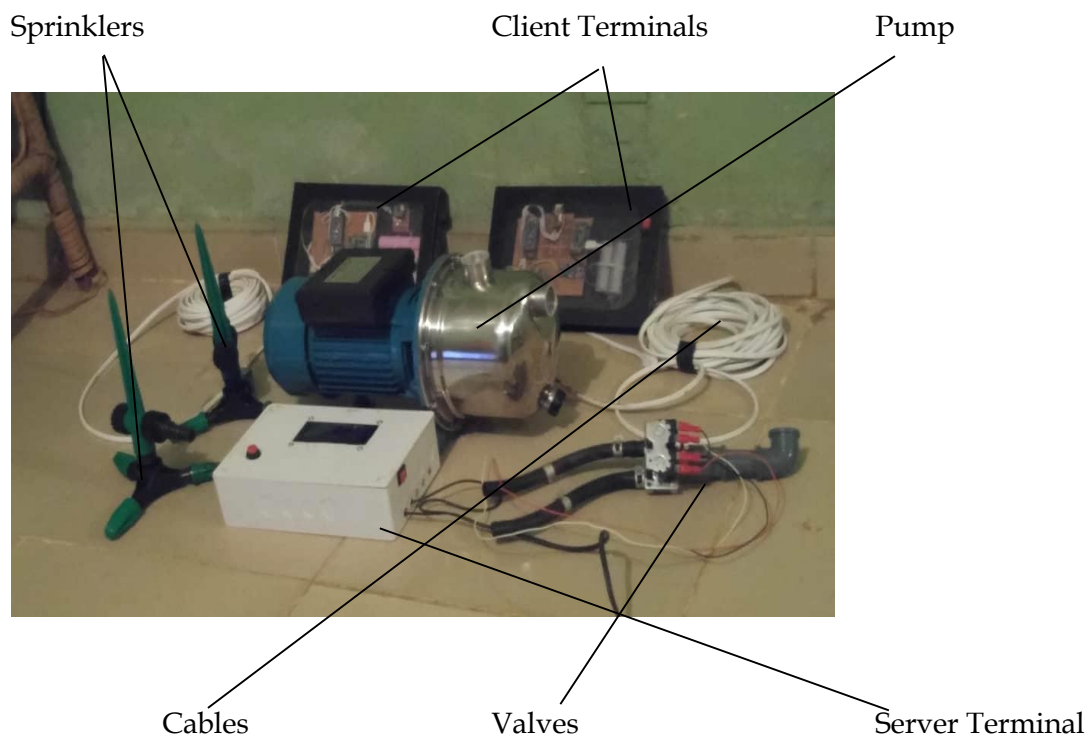

**Fig 2:** Irrigation System Setup

### The Client Terminal

The client terminal is an on-farm irrigation device. As shown in fig. 3, at the heart of the terminal is an Arduino Nano Microcontroller that is powered a rechargeable 5V DC. Soil, temperature and humidity sensors are connected to the microcontroller and their reading are sent through the microcontroller to the server terminal via the wireless radio. The wireless reading also receives command or instructions from the server terminal.

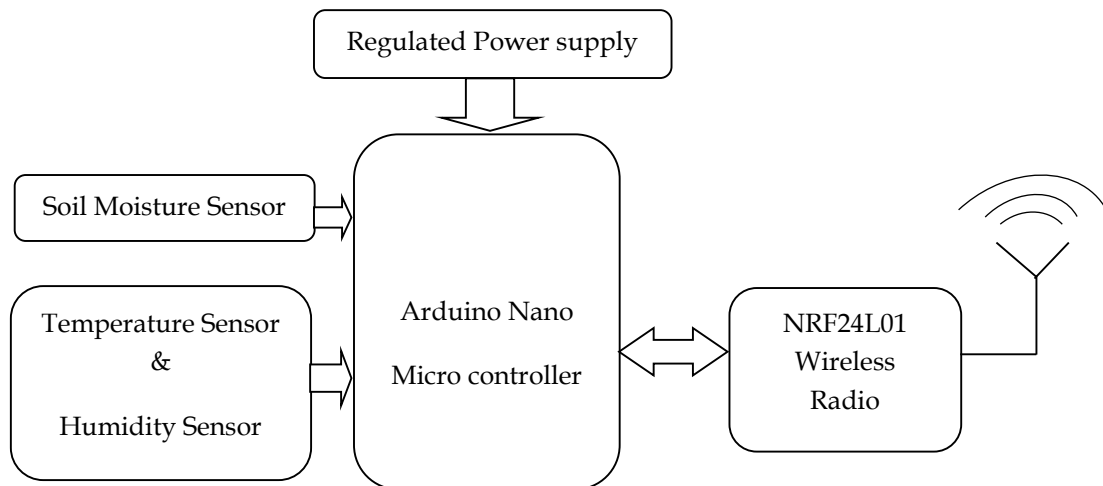
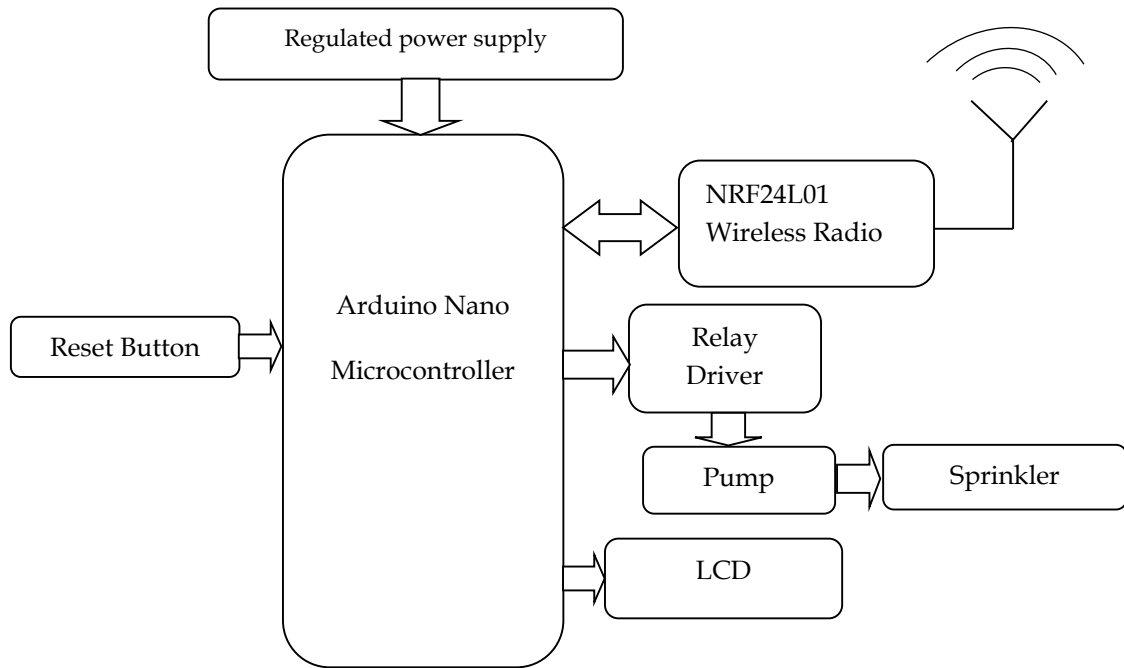

Fig 3: Irrigation System Client Terminal

### The Server Terminal

The Server Terminal is an on-farm device that does not reside within the farming area like the Client Terminal. Using the Line of Sight radio (LoS) connection technique, the radios kept within the range for adequate connections within the terminals. As shown in fig 4, once readings are received with the wireless radio, the microcontroller which is powered by a 5V rechargeable DC power compares the readings with the set thresholds to determine the action to be taken. If irrigation is required, the microcontroller sends signals to the relay driver which then turns ON the pump. Depending on which client terminal requires irrigation based on the set priority the corresponding valve is opened for water to flow to the farm area. The LCD displays the present action been taken while the reset button returns the terminal to initial conditions when the need arises.



**Fig 4:** The Server Terminal



### Operation of the Irrigation System

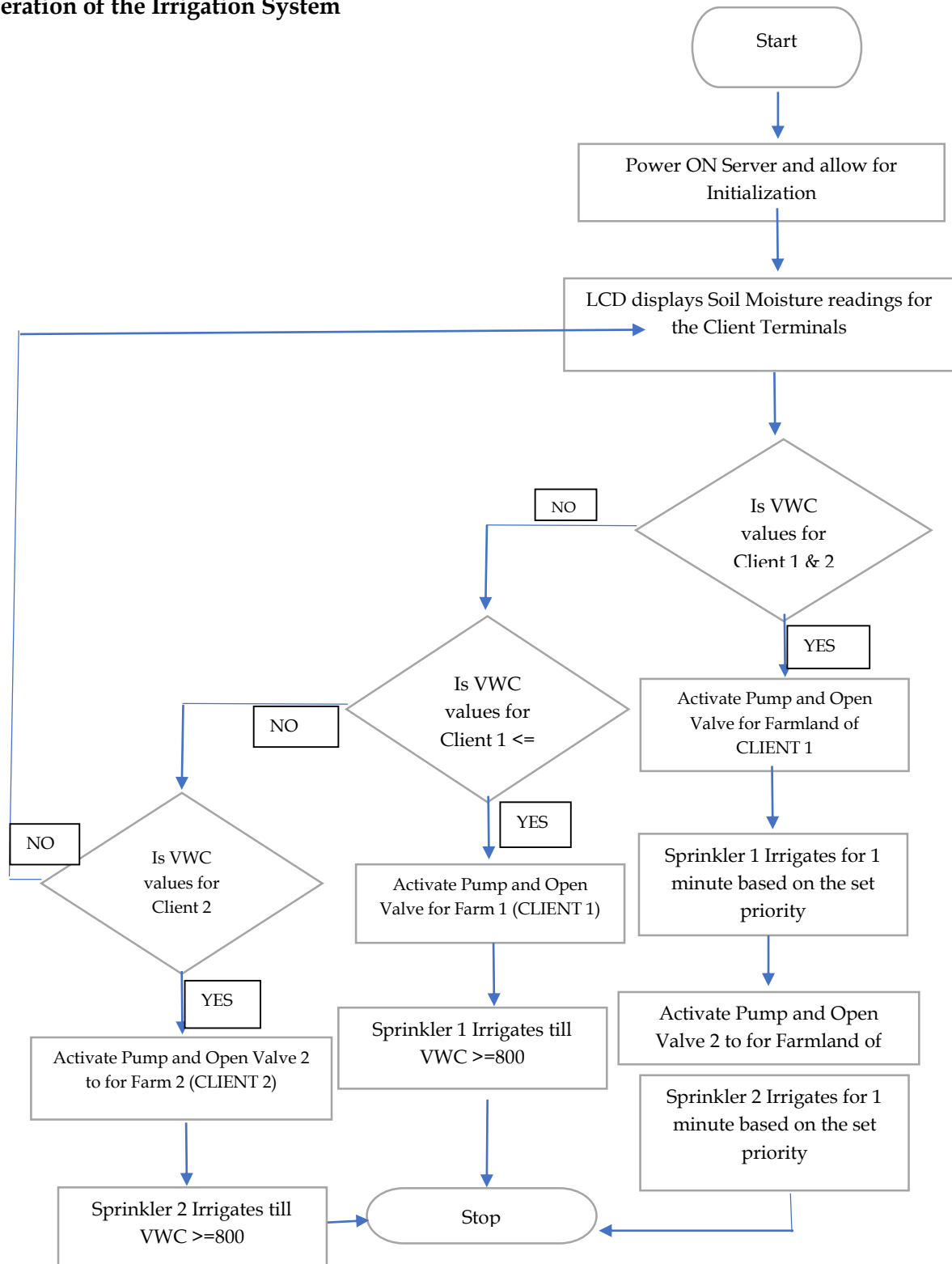

Fig. 5: Flowchart Showing the Operation of the Irrigation System.

The operation of the irrigation system requires that soil sample of the farm where the client terminal will be placed be taken for test to determine the Volumetric Water Content (VWC). The determination of VWC is needed to set the water content threshold from the moisture data that will trigger the pump ON/OFF. For discussion of the working operation of this irrigation system, a VWC of 400 and 800 thresholds was assumed. When the server is switched ON, it goes through the initialization process then the server LCD (Liquid Crystal Display) shows the soil moisture readings received from both clients situated on different sections of the farmland. At startup, as shown in fig. 5, the clients send the sensors readings to the server for analysis. As programmed, the server then checks if the values for both clients are the same and if so, the server sends a signal to the pump to activate valve 1 of the pump based on priority order assigned to the system to sprinkle water to the farmland covered by client 1 device on the farm. This will be done for one (1) minute before the server switches to the second valve to sprinkle water on farmland covered by client 2 for another minute.

If the soil moisture readings received from both clients are not the same, the server further checks if the soil moisture reading from client 1 is less than the threshold value, if so, the server sends a signal to the pump to activate valve 1 of the pump in order to sprinkle water to the farmland covered by client 1 device on the farm. However, once the VWC threshold reaches 800 the microcontroller sends a signal to turn OFF the pump. If otherwise, the server checks if the soil moisture reading from client 2 is less than the lower threshold value, if so, the server sends a signal to the pump to activate valve 2 of the pump to sprinkle water to the farmland covered by client 2 device on the farm. The pump gets a signal to turn OFF from the microcontroller once the VWC is greater than the upper threshold value. However, if the clients' readings are more than the threshold value, a command is sent back to the LCD to display the current soil moisture reading from both clients and the whole process repeats itself.

For the smooth running of the irrigation system, C language was used to develop codes for the system (client and server respectively). These codes were transferred to the irrigation system through the microcontroller which coordinates and controls the operation of the system.

#### Advantages of the Irrigation System

The Irrigation System possesses the following advantages;

1. Simplicity in design and installation
2. It finds its usage in all climatic conditions.
3. It works well in all types of soil as the determination of VWC regulates the use of water.
4. It adequately conserves water usage in irrigated farming.

5. Reduces soil erosion and nutrients leaching that may occur due to over-irrigation.
6. Good for large scale farmers whose farmland might have varying soil texture.
7. Guarantees high crop yield due to adequate and frequent supply of water.

#### Disadvantages of the Irrigation System

The disadvantages of the irrigation system are as shown;

1. Not of economic value to small scale farmers.
2. Deterioration of plastic materials used to construct the casing for the client terminal might be rapid in hot and harsh weather conditions.
3. High setup cost
4. Frequent maintenance required to ensure an efficient operation for optimal crop yield.

#### Conclusion

The microcontroller irrigation system is a real-time system that monitors the soil, humidity and temperature conditions on the farm continually via a client terminal and sends the most recent readings to the server terminal for analysis and control of the irrigation system via the RF radio link through the microcontroller. This irrigation system is highly scalable as the number of client terminals can be increased to cater for more farmland without affecting the performance of the server terminal. Also, the increase in client terminal does not require an increase in the number of pumps rather an increase in the valve and laying of water pipes to the new farm areas is required. This means that an increase in the farm coverage of this irrigation system will cost less and guarantees the cultivation of more farmland hence, an increase in food production. Also, adequate water conservation is assured as water is dispersed to the required farmland covered by the client whose VWC is less than the lowest threshold value and supply of water ends once the VWC value is above the upper threshold value. In summary, this irrigation system is resilient as it adapts favourably to all weather condition and soil types thus, ensuring regular food production all year round through farming with in turn ensures an increase in income needed for rural development.

#### Reference

- Ashok P. & K. Ashok. (2010). Microcontroller-Based Drip Irrigation System, *International Journal & Magazine of Engineering, Technology, Management and Research*. ISSN No. 2320-3706
- European Commission Report (2018). *Sustainable agriculture and rural development policy - agricultural development*, Retrieved from: [https://ec.europa.eu/europeaid/sectors/food-and-agriculture/sustainable-agriculture-and-rural-development/agricultural-development\\_en](https://ec.europa.eu/europeaid/sectors/food-and-agriculture/sustainable-agriculture-and-rural-development/agricultural-development_en) on August 21

- Hamouda, Y. E. M. (2017). Smart irrigation decision support based on fuzzy logic using wireless sensor network, *International Conference on Promising Electronic Technologies (ICPET)*. DOI:10.1109/icpet.2017.26
- Harun, A. N., Kassim, M. R. M., Mat, I., & Ramli, S. S. (2015). *Precision irrigation using wireless sensor network*, International Conference on Smart Sensors and Application (ICSSA). DOI:10.1109/icssa.2015.7322513.
- Hossain, M., (2014). *Poverty alleviation through agriculture and rural development in Bangladesh: Centre for Policy Development, Bangladesh (CPD)*. Retrieved from: <https://www.eldis.org/document/A20674> on August 21, 2018.
- Mehmet, F. I., Yusuf, S., Cemal, Y., Veysel, Ö., & Ercan, N. Y. (2017). *Precision Irrigation System (PIS) Using Sensor Network Technology Integrated with IOS/Android Application*. Applied Sciences. DOI.org/10.3390/app7090891.
- Ogunyinka, O. I. & Olorunsogbon, B. F. (2016). *ICT & Agriculture: The technical tool Required for repositioning the Nigerian economy*, 5<sup>th</sup> Academic Staff Union of Polytechnics (ASUP) National Conference. 16 – 19 October, 2016
- Punde, S. S., Vise, M. A, Sanap, M. B. Kamble. A. S. (2017). *PLC Based Irrigation System*. IOSR Journal of Electronics and Communication Engineering. e-ISSN: 2278-2834,p- ISSN: 2278-8735, PP 33-36

## INDUSTRIAL RELATIONS PRACTICES IN RIVERS STATE: THE VIEWS OF THREE HOST COMMUNITIES

**John Mark**

Department of Management  
Faculty of Management Sciences  
Rivers State University

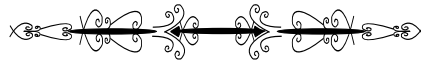

### **Abstract**

*Industrial relations practices require the demand on the part of the publicist to foresee emerging conflict, communicate same and represent existing organization's interest and as well analyze human industrial issues as required by common sense and ethics. Perpetual outbreak of conflicts, whether between the management and her internal publics or striving communities remains that the industrial relation officer is incompetent. The paper then intends to investigate into the efficiency role of industrial practice from three selected companies in Rivers State. Three communities were employed to this effect, thus Aluu, Choba and Alakahia. Result shown through the use of Linkert's scaling method, revealed that the issue of dishonesty; follow-up and availability of industrial relation officers accounts for the continual outbreak of conflict. It then remains, the paper concludes, that conflicting communities can be rid off crisis if the companies so wish, thus by strategically positioning their industrial relations offers*

**Keywords:** *Evaluation, Boarder, Housing Characteristics, Development, Ogun State*

### **Introduction**

Industrial relations practice demands the functions of a trained publicist, it ranges from that of problem identification, feed backing between an existing organization and the host community, open communication on human interest issues; representations of the organizations in litigation matters and all such issues that will require collective bargaining.

It then follows the industrial or community peace is solely the role of the industrial manager. As the name implies, he is required to mediate between the management and the employees. In Nicole (2018) this probably is why some scholars refer to it as employee-relations. For one issues with industrial relations have the tendency to affect an entire economy. What then remains is that an effective organization practice demands the impart of a well trained publicity (Adeyeye, 2001, 1995; Faj ana, 2000).

Going by this then, the continual conflicts between companies and their host communities in Rivers State, calls for the paper. For one again, if it is in the duty of the industrial relation manager to foresee conflicts and check them, it probably means that most of the companies with conflict tone are not really practicing.

The paper researched on three communities in view to seeing if the global roles of the individual relations managers are being felt by these communities. Conflict rate in most communities will be greatly checked if indeed the companies are making use of the services of industrial relations managers. For sure many of these companies have industrial relations unit, but not according to practice. As argued by Nicole (2018) organizations are productive in their host communities when the services of good industrial relations are instantly improved in cases where practitioners perform below global expertise. As well, employees' non-chalance to work can greatly reduce when good work relations exist. Employees would be encouraged as well the external publics of the company.

The paper then avers that the continual conflict between companies and their host communities and sometimes between the internal publics and the management is the cause of the industrial relations manager. The argument that the local chiefs or the youths of the communities or the employees are ingrate and could be conflict involving, is not always the case (Adeyeye, 1995 ; Fashoyin, 1980).

In a work published by Westfordadmin (2016), besides other roles of the industrial relations managers, there is most importantly the role of labour and customer relation management. The latter requires the place of honesty in transactions; availability of the manager to the issues involved and above all, the issue of follow-up. The absence of these, to a large degree, can engender conflicts. The paper then intends to inquire into the following objectives.

- i. Examine the most common problems associated with industrial relations practice in three communities in Rivers State.
- ii. To see if these problems have any correlation with the continual outbreak between existing companies and the host communities.
- iii. To determine if the continual conflicts in the communities is the function of the local chiefs, the youths or the industrial relations managers of the existing companies.

### **Research Question**

The following research questions x-ray the tone of the paper.

1. What are the most common problems associated with the practice of industrial relations in these communities?
2. To what degree do these problems have any correlation with the continual conflicts in the communities selected?

3. Is the continual conflict between existing companies and their host communities the function of the youth, the local chiefs or the industrial relations manager?

### **Statement of Problem**

A number of factors account for the continual conflicts between companies and their host communities. Most often, hand-pointing and gain-sayings are attributed to the function of the youths of the communities and sometimes too, to the local chiefs. This divergence in opinions has continually defiled a united approach to conflicts involving companies and their host communities. The paper then argues that the companies themselves: (their industrial units) are the major cause of conflicts in some host communities. What then is involved, the paper argues. is that companies begin to strengthen their industrial relations units as this will go a long way in checking conflicts between them and their work environment?

### **Significance of Study**

The functions of industrial relations managers in third world states are not readily used in the management of conflict. What this shows is that the services of industrial relations managers are not being felt, thereby paving way for market gap and a breakdown in the economy. Restoring it then will not only maximize the economy, conflicts will be reduced as policy makers and organizations will have enough data to decide their activities with the environment concerned.

### **Conceptual Issues of Industrial Relations Practice**

Positions are that industrial relations practice does not exceed that of conflict management; labour and customer relations; analyses of emerging conflicts in host communities; communication, and all such that involve peace-keeping (Nicole, 2018; Leo, 2018).

By these roles then, companies can probably keep themselves safe out of trouble from both their external and internal publics. But even at that, conflicts have continually engulfed most industrial communities. This probably stems from the nonchalance of companies: specifically, their industrial relations unit. For one, in Sharma (2000) industrial relations came as a result of the nature of human society and the businesses around. Etimologically, it is the involvement of the term industry and the relations existing between workmen and the management. Knowing the nature of humans, there can be no productivity of labour without adequate compensations. Industrial relations then wide across work related issues, such as collective bargaining; power dominance; commitment of employees; conflict resolutions; pluralism and bilateralism of labour structure etc. Kumar (1961).

What then is left over the years is that the human society is industrially inclined and the consequence is the tendency for humans to conflict themselves. The emergence of industrial relations then should be able to check this, Allan Flanders (1970), Fashoyin (1992). It then

follows that conflicts have continually defiled occupational knowledge due to nonchalance of industrial practitioners. This is mostly so in third world states where office span does not exceed the role of the general managers. In some companies too, the human resource manager acts as the industrial relations officers but without the basic information or knowledge of the office he occupies. In Nicole (2018), human resource unit is distinctive from the work of the industrial relations officer. Essentially, it does not exceed that of communication between the management and the external and inter publics. The life of communication according to (Fajana, 2015) is an applied one; which further helps industrial relations manager resolve impending conflict (Adeniji et al., 20015). In labour relations commissions code, it is stated that the industrial relations officer. primarily known as employee relations representative, is saddled with the following responsibilities.

1. Represent members effectively on relations to matters arising within the industry or establishment.
2. Participate in negotiations as established by respective customs
3. Act in accordance with existing laws and regulations of the union and the industrial relations practice.
4. Having regards for the good and operations of the industry.
5. Maintaining and keeping jobbing standards; company-rules; disciplinary conditions etc. Source: Section 42 of the Industrial Relations Act (1990).

The above duties then underscore, content wise, the role of the industrial relations manager as the gate keeper of the relations between the establishment and her workmen or the external publics. It then follows that the continuous conflict in most communities in Rivers State, especially between the communities and companies is due to incompetence on the company's industrial relations unit. It is no doubt true that the youth and the local chiefs, to some degree, contribute to ridden conflicts, but this is not exceedingly beyond the expertise of the industrial relations officer.

### **Attachment Theory**

One major theory that underscores the natural need of conflict is that of attachment theory advanced by Thomas N. Bradbury and Benjamin Kamey. Hence when people conflict they are unconsciously asking for attention, especially where their needs are in the hands of an attachment figure.

Attachment theory then argues that humans have attachment behaviour system which helps them check how close or distant they can be with another. Thus when they perceive the attachment figure to be responsive they become relaxed. They become vindictive and agitation when they feel that the attachment figure is non present and responsive to their needs.



It then follows that the continual crisis in some communities stems from the perception of the communities have about the industrial relations unit of the companies as being nonresponsive to their needs. In order to draw the attention of their attachment figure which is that of the companies, they become volatile. Socially speaking these communities are emotionally attached to their environment and to the working companies and the companies not being responsive to their needs engenders conflict.

### Methodology

Three communities in Obio/Akpor Local Government were adopted for the research. Out of the three communities, fifty youths each, were interviewed. The intention of the researcher in using only the youths was because they are the ones who mainly engage in conflict with the working companies. Furthermore, the use of Linkert's scaling method was used in the analysis of result.

### Presentation of Data Analysis

**RQ1:** What are the problems associated with the practice of industrial relations in your communities.

Item		A	U	D	SD	TOTAL	La
The problems in the industrial relations in your community range from that of dishonesty, non-availability of the industrial relations manager, absence of follow-u	5 90 450	4 30 120	3  0	2 17 34	1 13 13	15 150 607	4.0

The result from the above table holds through to the objective of the research, which was to find out the major problems associated with the practice of industrial relations in three communities in Rivers State, thus Choba, Aluu and Alakahia. Hence, the result-4.0.

**RQ2:** Do these problems in anyway contribute to the conflicts in the communities

Item	SA			D	SD	TOTAL	La
Conflicts continue in the communities because of these problems	5 135 675	4 10 40	3 1 3	2 1 2	1 3 3	15 150 732	3.0  4.9

As well the result in the above table holds through to the fact that the issue of dishonesty lacks of availability of attachment figure (industrial relations manager) to the communities and the

issue of follow-up, have continually contributed to the outbreak of conflicts between the companies and host communities.

**RQ3:** Are the youths and the local chiefs the major cause of outbreak of conflicts in the communities?

Item		A	U	D	SD	TOTAL <sup>E</sup>	La
The industrial relations managers sent to the communities are sometimes the major cause	5	4	3	2	1	15	3
of conflicts in the communities and not necessarily the youths or the local chiefs.	122	16	2	3	7	150	
	610	64	6	6	7	693	4.6

### Conclusion

The paper then concludes from the above result that, often times, the industrial relations managers constitute a greater cause of the conflict. Even if relief aids have been sent to the communities; there is need for a follow-up; honesty in negotiations and above all availability of the manager to the communities. It then follows that existing companies must adopt these li fZ • styles in order to be conflict free, at least to some degree.

### References

- Adeyeye, J.O. (1995). Conflict and conflict resolution in work organization. *African Journal of Labour Studies*, 3 (1), 25-34
- Adeyeye, J. O. (2001). Industrial relations: Economic development and democracy, *Nigerian Journal of Industrial Education and Labour Relations*, 3 (1), 3 1-43
- Bradbury, T.N., Benjamin, R.K., *intimate relationships* [www.wwnorton.com](http://www.wwnorton.com)
- Cede of Practice (1993). *Labour relations commissions and industrial relations H.Ct of 1990 on employee representatives*
- Fajana, S. (1995). *Industrial relations in Nigeria: Theory and practice*, Lagos: Labotin Co. pp. 121-126
- Fajana, S. (2000). *Industrial relations in Nigeria: Theory and features*, Lagos: Longman Group. Ltd
- Fashoyin, T. (1980). *Industrial relations in Nigeria*, Longman Group Ltd

Fashoyin, T. (1992). *Industrial relations in Nigeria: Development and practice*, Lagos: Longman, Nigeria, P.C. 219-233

Four pillars of employee-relations, [small business.chron.com](http://smallbusiness.chron.com)

Imafidon, J. (1996). *Industrial relations*

Leo, I. (2018). *What is industrial relations? Small business*. [Chron.com](http://Chron.com)

Management Study, Ho: *Causes of industrial disputes*. [small business.chron.com](http://small business.chron.com)

Nicole, F. (2018). *Managing employees work schedule small business*. [small business.chron.com](http://small business.chron.com)

What is employee-relations? *Small business*, [chron.com](http://chron.com)

## PERCEIVED LEGISLATION AND E-COMMERCE ADOPTION: EVIDENCE FROM SOUTHWEST NIGERIA

<sup>1</sup>Taiwo, Akeem A. <sup>2</sup>Omojaro, Anthony O. & <sup>3</sup>Ademola, Emmanuel A

<sup>1&2</sup>Department of Business Administration and Management,  
Federal Polytechnic, Ilaro, Ogun State, Nigeria

<sup>3</sup>Department of Accountancy,  
Federal Polytechnic, Ilaro, Ogun State, Nigeria



### Abstract

*Business organizations are now moving from the traditional and limiting way of transacting to the modernized and unlimited way of exchanging goods and service without much physical contact between both parties which is the underlying principle behind e-commerce. However, one of the major and prolonged concern that restricts its adoption by customers and organizations is perceived legislation which regulates activities on the internet. The study explored the resultant effect of perceived legislation on e-commerce adoption by customers in South West Nigeria. The study adopted mixed methods using structured questionnaire and in-depth interview. Six hundred and sixty-six (666) copies of questionnaire were administered on the customers of four top e-commerce organization in Southwest Nigeria. Six-hundred and twenty-one (621) were retrieved while six-hundred and ten (610) were used for analysis. Quantitative data analysis was carried out through descriptive statistics, Confirmatory Factor Analysis (CFA) and Structural Equation Modelling (SEM) using (STATA 12) and the hypothesis was tested with the use of regression analysis. The findings revealed that the implementation of proper legal and regulatory issues as regards internet will have great effects on the adoption of e-commerce in Southwest Nigeria. Based on the findings, the study recommends that government should take the role of leadership by giving priority to consumer protection, enacting and implementing regulatory guidelines for e-commerce transactions that will keep cyber-crime in check.*

**Keywords:** *Internet Security, Perceived Legislation, E-commerce; E-commerce adoption, E-commerce acceptance, E-commerce use*

### Introduction

It is generally conceded that it is critical for organizations to accept e-commerce and adopt internet innovations by creating a framework that will support the practice of e-commerce (Kaur and Kaur, 2015). There is development in the quantity of internet clients around the

globe and this development has given the power and the odds for worldwide e-commerce (Lawrence and Tar, 2010). The innovations in e-commerce include items, services and data seeking, publicizing, purchasing, offering and making payments for items and additional benefits (Allen, Bresnahan, Childers, Foster, Kandaswamy, Kettimuthu, Kordas, Link, Martin, Pickett and Tuecke, 2012). Haseeb, Arshad, Ali and Yasin (2011) characterize e-commerce as an extensive variety of online business exercises for items and services.

Lawrence and Tar (2010) stresses that it has been anticipated that online business will be another driver of monetary development for developing nations. The difficulties poised by internet advancement which is basic for e-commerce have driven a lot of people to recognize that e-commerce will grow rapidly and help developing countries to beat their reality of economy dismissal issues and change in their participation terms (Odedra-Straub, 2003). Jebur, Gheysari and Roghanian (2012) portrays internet and e-commerce as a basic piece of the procedure of improvement of business transactions. In any case, legislations have made a huge difference in the adoption, use, development and clients' loyalty to e-commerce in developing nations (Agwu, 2015).

Agwu and Murray (2014) opined that customers recognize what dangers are present and challenges which are outcomes that are common such as identity theft or information, accordingly, they have a sentiment towards doubt and dread. In this situation, organizations are relied upon to protect the information and almost all the clients need more confirmation that data is safe and secure (Rawabdeh Zeglat and Atzawahreh 2012). Nonetheless, e-commerce is still in its young stage in various developing economies around the world. Numerous researchers like Agwu (2015), Chemeke, Elowekpaefe, Okpo and Irhebhude (2014), Ahmed and Hasan (2016), contended that this is because of numerous components that still stand up to and challenge e-commerce adoption especially legislation guiding the conduct of business transactions online. Satisfactory enactments and legislations regulating the use of internet by clients and organizations is one of the many factors that mitigates against the successful adoption of e-commerce.

Ackerman and Davis (2008), learned that government in developed economies like United State of America (USA) and United Kingdom (UK) have made different attempts whether by law or by declaration keeping in mind the end goal to manage e-commerce exercises in the interest of their residents. This include rising legitimate points of reference and case law to oversee protection on the internet. In any case, control attempts have been restricting and befuddling. For example, the European Commission (EC) chose to blend information security control spreading over European Union members and proposed the rule on the protection of people as regard to the handling of individual information and on the free use of such

information. All individuals from the European Union join this enactment with their domestic law in 1998.

Smith and Shao (2007) found that in light of this enactment, individual information can be exchanged with non EU nations, if satisfactory level of security can be ensured. Nonetheless, numerous developing economies like Nigeria has not set up satisfactory legislation so as to secure individual information of clients which has decreased sufficient ease of use and adoption of e-commerce business by customers in the country. It is for this reason that this research set out to examine the impact of perceived legislation on the use of e-commerce in Southwest Nigeria.

## **Literature Review**

### **Perceived Legislation**

Legislations and regulations incorporate the different endeavors by government either by law or pronouncement, keeping in mind the end goal to give appropriate controls to the e-commerce business condition for their citizens (Ackerman and Davis, 2008). This is essential because of the way that the foundation and adoption of a dependable approach and administrative structure would energize quick advancement of e-commerce with the related advantages for the economies and residents (Maaruf and Abdulkadir, 2012). Kinuthia and Akinnusi (2014) opine that legislature must set up clear laws, principles and control, make arrangements of important specialized training to the administrative expert to allow them to uphold the laws satisfactorily. The enactment should likewise include the rising lawful points of reference and case law that oversee security in the internet.

Rehman and Alam (2016) explain that a current study conducted among Brazilian shoppers found that the low level of e-commerce adoption was because of government controls like tension about privacy and security, absence of business laws for e-commerce, insufficient lawful insurance for internet buys and internet tax assessment concern. Similarly in china, noteworthy obstructions to e-commerce acceptance are absence of 'value-based and institutional trust which is the result of frail tenets and laws' (Efendioglu and Yip, 2004).

Be that as it may, there is requirement for parties at the core of e-commerce to shape substantial and legitimately restricting contracts on the internet. Basic inquiry is the means by which contracts on internet can be framed, performed and implemented as paper records by parties included. Another worry about enactment is the means by which digital debate between e-commerce accomplices are unravelled and as indicated by which laws and where. Laws of different nations ought to be examined and there ought to be adoption of worldwide standard approaches (Kraft and Kakar, 2009). The non-accessibility of lawful online business enactment in the developing economies give a chance to governments to kick-start the procedure by setting up model for e-commerce legislation that can be executed without a wide

harmonization battles that will be required if legislation is required in other developing economies (Maaruf and Abdulkadir, 2012).

Moreover, Kaur (2005) states that security help and draft laws on e-computerized mark can endeavor to handle violations in computer data zone. Clients and organization will be forestalled in the selection of internet business by nations that are not worried on the computer wrongdoing or online exchange's security.

### **E-Commerce**

E-commerce or internet business is viewed as an extensive variety of e-commerce exercises for products and enterprises. It can likewise be alluded to as any type of business movement in which the interaction between parties is electronically as opposed to physical trade or direct physical contact (Adewale, Ayo-Oyebiyi and Adebayo, 2013). Turban, Lee, King, McKay, Lee and Viehland (2008) consider e-commerce as the methodology which incorporates acquiring, offering, trading or exchanging items, services and furthermore information through computer frameworks, including the web. E-commerce has been touted as a road to achieve worldwide clients by picking up pieces of the overall industry with brings down cost (Agwu, 2012). This is anyway accomplished by streamlining a vast scope of business procedures and innovation for upper hand utilizing media transmission and relationship change systems (Agwu and Murray, 2014). Turban *et al.* (2008), distinguish between internet and non-internet e-commerce. The non-internet e-commerce includes for example to purchase and pay services on merchandise with smart cards by utilizing candy machines or potentially exchanges undertaking through system like Local Area Network (LAN), by the utilization of intranets or even single automated machines.

Different authors categorized e-commerce diversely in various settings (Agwu and Murray, 2014). Chaffey, Ellis-Chadwic, Mayer and Johnson (2009) sorted internet business into:

- 1) **Customer to Customer (C2C):** Where buyers execute specifically with different shoppers on the internet. Additionally, Hoffman and Novak (1996) portrayed C2C communications as an imperative model in internet based exchanges and proposed the requirement for organizations to put that advancement into thought in their endeavors towards advertise arrangement. This insistence is shown by the improvement of online networking system sites as of late, for example, Instagram, Twitter, Facebook and so on. Illustration incorporates individual to person.
- 2) **Business to Customer (B2C):** Where the clients find out about merchandise or services by means of electronic publishing, and buy them by the utilization of electronic money and secure payment frameworks and have the products conveyed electronically or through physical channel (Vaithianathan, 2010). Illustration includes Konga and individual.

- 3) **Business to Business (B2B):** is an electronic market trade in which business, governments and distinctive organizations depend upon PC to PC correspondences as a fast, proficient and a trustworthy technique to coordinate business trades. Example includes Konga and Union Bank.
- 4) **Customer to Business (C2B):** is the sort of online transactions where shoppers start exchanging with organizations—these are generally providers. Example includes Individual and Nigeria Breweries.
- 5) **Customer to Government (C2G):** is a sort of online connection where feedback is given to government through pressure group or individual webpage. Illustration includes Civil Society of Nigeria (CSN) and Ogun state government.
- 6) **Business to Government (B2G):** is a sort of online transaction where feedback is given to government and non-government organizations from businesses. Illustration includes Cadbury Nigeria Plc. also, Lagos State Government.
- 7) **Government to Citizen (G2C):** is a kind of online transaction through which government offer national exchanges, for example, local government services, national government data, and tax data. Illustration includes First Inland Revenue Service (FIRS) and Nigeria nationals.

By and large, the main dynamic type of e-commerce in Nigeria are (B2B) Business to Business and (B2C) Business to Customer. Different models, for example, G2C, C2G and B2G have not been very much developed. In light of this, the investigation will center around the effect of perceived legislation on B2B and B2C adoption of internet business by clients in Nigeria.

## **Theoretical Review**

### **Diffusion of Innovation Theory**

The Diffusion of Innovation (DOI) theory was selected as a directing hypothetical framework for this research which is striking in the innovation adoption writing and used to get understanding into the level of e-commerce diffusion and adoption by customers. DOI was created by Rogers (1995) to depict the procedure by which an innovation is imparted through specific passages over time in the midst of individuals from a social framework.

In accordance with different past scientists, Rogers (1995) has found that people in a social framework do not at a similar period receive an innovation. Rogers (1995), distinguishes profound attributes of innovations as perceived by people. These are critical as they are presented such that potential adopters may see the advancement.



Fig. 1: Diffusion of Innovation

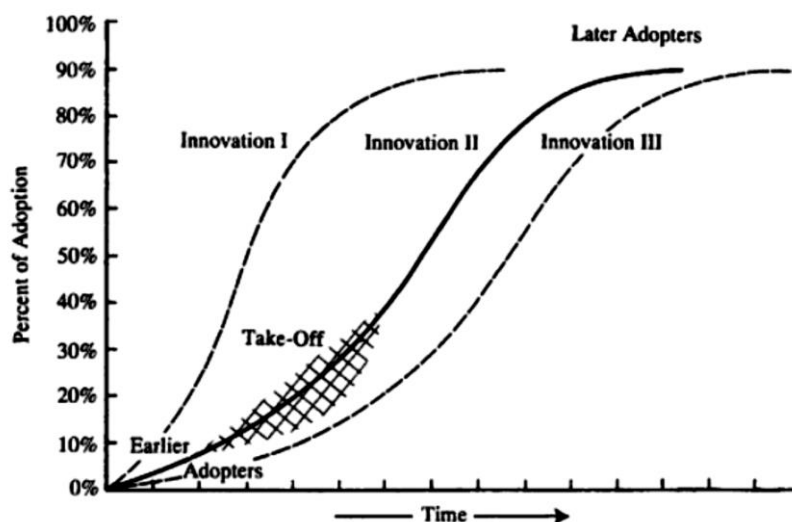

Source: Rogers, (1995)

The features that creates the base for what is regarded as perceived attributes of Innovation Diffusion according to Oluyinka, Shamsuddin, Wahab, Ajagba and Enegbuna (2013) includes:

- i. **Relative Advantage:** This is delineated as how much good position of adopting e-commerce is viewed as better than not embracing it. Relative advantage position requests the buyers to survey the favorable circumstances and obstructions of using the e-commerce innovation, which can be imparted in a social, financial and other ways.
- ii. **Compatibility:** This is how much an advancement apparently is unsurprising with the esteem that has been in existence, past encounters and necessities for potential adopters. The social estimations of potential e-commerce adopters are assessed in connection with the characteristics and trust system, formal displayed considerations and necessities of buyer for the innovation.
- iii. **Complexity:** This is the degree to which an innovation is viewed as difficult in comprehension and utilization. Multifaceted nature considers the level of physical or mental undertakings required to use an e-commerce innovation for day by day business exercises.
- iv. **Trialability:** This is the level to which a development can be placed in try inside restricted base. It allows the adopter to have preparatory appraisal of an innovation in order to offer importance to the adopter.
- v. **Observability:** This is the level at which the results of an innovation are reasonable to others. The earlier it is to see the result of innovation by potential adopters, the more

likely for them to receive it. The more the advancement can be noticeable and be conveyed by others, the more prominent the observability (Rogers, 1995).

Another essential thought in the adoption of an innovation are the attributes of the potential adopters. Rogers (1995) certifies that this characteristic includes societal position, educational level, level of cosmopolitanism and measure of ingenuity. Abrahamson and Rosenkopf (1993) offers a slight diverse position on adoption which they alluded to as 'bandwagon effect'. They demonstrate that occasionally when innovation is adopted by individuals or organizations, it is not a direct result of specialized properties but because of the sheer number of others that have effectively embraced it. The band wagon impact would appear to be identified with 'perceptibility' qualities of an innovation talked about previously. A portion of the qualities of DOI are reasonable for this study. It has been utilized as a part of different past investigations at the levels of individual and firm. Moreover, its elements help with understanding the bearing of the decision makers towards executing the new systems in working environment, particularly the information technology components like e-commerce (Oluyinka *et al.* 2013). For instance, countless undertakings in Nigeria operate in the informal sector of the nation, and relatively noteworthy number of abroad based firms were detached from whatever is left of the economy (Abdel-Nasser, 2012).

Researchers on innovation diffusion are limited in developing nations and all-inclusive frameworks are not all around associated with neighborhood substances, particularly to the requirements and chances of labour market. This study considers a brighter comprehension of what is implied by innovation in developing nations as a vital factor that advance e-commerce adoption. Laws and regulations are affected by innovation diffusion theory and therefore are pivotal in deciding adoption and acceptance level of e-commerce in developing nations.

### **Empirical Review**

Chimeke, Elowekpaefe, Okpo and Irhebhude (2014) take note of that perceived legislation is a basic hindrance to the adoption of e-commerce by clients. They went further to state that if legitimate enactments and directions are set up, clients will complete e-commerce exchanges. However, Mittal (2013) contends that media transmission and computer network headway are fundamental parts of the economic infrastructure. The study noticed that a few factors, for example, financial, social, political, legal and supernatural foundations are the worldwide powers that influence the adoption of e-commerce and its structures in developing nations.

Dan (2014) turned out with different factors about adoption of E-commerce by SMEs all around. One of this is individual variables which has to do with the executives of the firm staff and clients that transacts business with the firm. These are the group that are affected

broadly by e-commerce adoption. He went further to express that mindfulness and training of people are amazingly critical previously, in the midst of and after the execution of E-commerce. Another factor mitigating the adoption of e-commerce by SMEs as affirmed by Dan (2014) is organizational.

This clarifies the nature and highlights of the organization, this continually influence the organization to have an upper hand. These elements include security, trust, privacy concerns, financial ability and cost implications, size of business, perceived ICT benefits and organizational culture. Other factors noted are environmental, that identifies with competitiveness pressure, government rules and regulations among others. The technical factors as noted include the absence of internet security which is viewed as a noteworthy barrier to the adoption of E-commerce by the SMEs. The study presume that absence of fundamental financial, legal and physical infrastructure for e-commerce in developing nations affects e-commerce adoption in the developing nations. The study however is limited as it fails to identify other major determinants of e-commerce adoption regarding trust, risk concerns amongst others.

The adoption and dispersion of e-commerce in developing economies is impacted by political and legal issues which includes government policies and support lawful condition and practices (Efendioglu *et al.*, 2003). The legal and political atmosphere of a nation can significantly affect the development of e-commerce where there is no sufficient cooperation from the government (Mbarika, Okoli, Byrd and Datta, 2005). The study is limited in its findings as it did not identify other security factors as determining factors of e-commerce use.

Oluyinka *et al.*, (2013) considered e-commerce adoption factors in Nigeria using Nigerian post graduate students in Malaysia as case study. The population targeted was chosen since e-commerce exchanges requires high internet education and that section of populace knows about online exchanges particularly online banking. The study analyzed different obstructions upsetting the adoption of e-commerce in Nigeria.

The first recognized is infrastructural barrier that needs to do with media transmission interfacing with the internet which is not accessible in view of poor phone organizations and epileptic power supply. Others are social components which include absence of trust between parties associated with the exchange, financial barriers like economic state of a nation is additionally a thwarting element and political and legislative obstructions, for example, government policies on information technology and other communication pose noteworthy difficulties to the adoption of e-commerce in Nigeria. The investigation gave a standard to imperative thought to enhance e-commerce selection focused on innovation framework and answer for inconsistent power supply. As revealing as the study is, it didn't highlight the

relevance of other security factors such as perceived trust, risk, privacy concerns as well as internet experience as determinants of e-commerce adoption.

Ma'aruf and Abdulkadir (2012) considered the execution of e-commerce in developed and developing nation using United States (US) and Nigeria. The study recognized a different component that contributes to e-commerce implementation success. The research went further to compare the adoption of e-commerce in both US and Nigeria. The research uncovered that there is fast development of e-commerce in developed nations because of the accessibility of e-commerce infrastructure when contrasted with developing countries. Likewise, there is increasing awareness with the benefits and opportunities presented by e-commerce among developed nations. There is also constant development of e-commerce because of high level of improvement in telecommunication services.

The developing nations on the other hand do not have the required financial, legal and physical facilities to develop e-commerce. In addition, countries as a rule have distinctive cultures and business methods of insight that put a limit to the relevance and transferability of the e-commerce models structured by western countries. The study noted that absence of overall policy framework that covers technical, economic and political policy consideration are the reasons behind slow development of e-commerce in developing countries. The study recommended that for e-commerce to succeed with regards to developing nations, there ought to be a legal framework conducive to e-commerce and the high cost of equipment, integration and connectivity should be addressed.

### **Methodology**

To pursue the objective of this study, the following was synthesized:

**H<sub>01</sub>:** Perceived Legislation does not significantly affect the use of e-commerce by customers in Nigeria.

For the purpose of this study, the researcher employed concurrent research design to suit the study mixed methods research approach. Concurrent research design is characterized by the collection and analysis of quantitative data in a first phase of research followed by the collection and analysis of qualitative data in a second phase that builds on the results of the initial quantitative results (Creswell, 2009).

The population for this study comprises of total population of e-commerce users of the e-service provider in South-West, Nigeria. These people have shopped at one time or the other. This is made by the researcher given the difficulty in determination of total e-commerce users in the study area. In other words, the population figure stands at 27,722,522 people as revealed by National Population Commission (NPC, 2010). However, the study population is

considered to be infinite as figure exceeds 50,000. With regard to the targeted population, the study focus on the four main pillars of e-commerce service providers in Nigeria which are Jumia, Konga, Payporte, and Yudala; as identified by Central Bank of Nigeria (CBN) Bulletin, (2017). The targeted population are e-commerce customers in South-West Nigeria that utilized the services of these e-services providers. Given the fact that literacy level of 69.1% in the geopolitical zone is higher than the National level of 57.9% (National Bureau of Statistics, 2010), the outcome of this study would not draw a total and comprehensive picture about e-commerce services in the South-West if the targeted population is not completely considered.

### **Sample and sampling technique**

The study utilized a sample determination formula by Cochran (1977) for infinite population to determine a representative sample for the study. Accordingly, the formula is given as thus;

$$n_0 = \frac{z^2 pq}{e^2}$$

Where,  $n_0$  is the sample size,  $z$  is the selected critical value of desired confidence level,  $p$  is the estimated proportion of an attribute that is present in the population,  $q = 1 - p$  and  $e$  is the desired level of precision (Cochran, 1977).

The study assumes the maximum variability to be 50% ( $p = 0.5$ ) and taking 99% confidence level with  $\pm 5\%$  precision, the calculation for required sample size will be as follows;

$p = 0.5$  and hence  $q = 1 - 0.5 = 0.5$ ;  $e = 0.05$ ;  $z = 2.58$

So,

$$n_0 = \frac{(2.58)^2 (0.5)(0.5)}{(0.05)^2}$$
$$n_0 = 665.64 = 666$$

Given the fact that  $n_0$  derived is less than 5% of the population size. This, however, brings no need to use correction formula as suggested by Cochran (1977) and as such the figure (666) represents final sample size.

Table 1 below reveals the sample frame chosen for this study.

**Table 1:** List of Monthly come-to-claim Customers of selected e-Commerce Providers in South-West, Nigeria for 11 months (January – November, 2017)

S/N	South-West States	State Capital	Number of come-to-claim customers of selected e-commerce Providers in South-West, Nigeria				Total
			<i>Jumia</i>	<i>Konga</i>	<i>Payporte</i>	<i>Yudala</i>	
1	Lagos	Ikeja	4,860	4,658	3,340	2,447	15,305
2	Ogun	Abeokuta	2,320	1,985	996	552	5,853
3	Oyo	Ibadan	3,680	3,064	1,638	998	9,330
4	Osun	Osogbo	1,800	1,710	715	519	4,744
5	Ondo	Akure	1,886	1,520	607	328	4,341
6	Ekiti	Ado-Ekiti	1,795	1,415	184	265	3,659
	<b>Total</b>		<b>16,341</b>	<b>14,352</b>	<b>7,430</b>	<b>5,109</b>	<b>43,232</b>

In selecting e-commerce samples from each e-commerce provider and from each state upon which copies of questionnaire were administered to explore required responses, the study adopted multi-stage sampling techniques. This comprises of purposive, stratified and accidental sampling techniques.

The study utilized a well-developed structured questionnaire and semi-structured interview to obtain data from e-commerce users on the perception of internet security and e-commerce adoption in South-West Nigeria.

The quantitative data analysis of the study was done using STATA version 12. Descriptive statistics was conducted on the demographics variables as a means of describing the respondents' characteristics using percentages and frequency distribution. The qualitative data was analyzed to support the quantitative findings using procedures such as transcribing all interviewee's initial discussions.

Table 2 below reveals the ultimate sample size selected for the study.

**Table 2:** Sample Size Distribution

S/ N	South -West States	State Capital	State Population (million)	Sample selecte d for each State	Sample Size Distribution among e- commerce Providers based on proportion to Sample Frame				<b>Total</b>
					Jumia	Konga	Payport	Yudala	
1	Lagos	Ikeja	9,113,605	219	70	66	48	35	219
2	Ogun	Abeokuta	3,751,140	90	36	31	15	8	90
3	Oyo	Ibadan	5,580,984	134	53	44	23	14	134
4	Osun	Osogbo	3,416,959	82	31	30	12	9	82
5	Ondo	Akure	3,460,877	83	36	29	12	6	83
6	Ekiti	Ado-Ekiti	2,398,957	58	29	22	3	4	58
	<b>Total</b>		<b>27,722,522</b>	<b>666</b>	<b>252</b>	<b>222</b>	<b>113</b>	<b>76</b>	<b>666</b>

### Validity and Reliability test

The research utilized content validity, internal validity and constructs validity techniques to validate the instruments and the information. Content validity was done through non-statistical specialists' judgments where research instruments and the information were evaluated by the specialists in the field of research, including researcher's supervisors. Internal validity was accomplished through triangulation where information were gathered by means in excess of one source: questionnaire and interview and field observations. Construct validity was analyzed and assessed through a progression of strategies by applying the exploratory factor (EFA) and confirmatory (CFA) techniques of Factor Analysis.

Table 3 below reveals the result of the validity test for the research instruments used.

**Table 3:** Convergent Validity for the Constructs

Construct	Composite Reliability	Average Variance Extracted
Perceived Legislation	0.79	0.84
e-Commerce Use	0.84	0.79

As regards reliability, Cronbach's alpha coefficient was employed to examine constructs internal consistency reliabilities.

Table 4 below reveals the result of the reliability test conducted on the research instruments used.

**Table 4:** Cronbach’s Alpha Reliability Test

Constructs	No. of Items	Cronbach’s Alpha ( $\alpha$ )	Comments
Perceived Legislation (PELE)	8	0.83	High Reliability
e-Commerce Use (EUSE)	6	0.85	High Reliability

**Data presentation and results**

**Table 5:** Breakdown Aggregate of Questionnaire Distribution and Retrieval

S/ N	South- West States, Nigeria	Total Distributed	Number of Retrieved Questionnaire				Total Retrieved	% Total Retrieved
			Jumia	Konga	Payport	Yudala		
1	Lagos	219	68	64	42	32	206	94.0
2	Ogun	90	33	28	14	8	83	92.2
3	Oyo	134	49	40	21	12	122	91.0
4	Osun	82	28	29	12	7	76	92.6
5	Ondo	83	35	26	11	6	78	93.9
6	Ekiti	58	28	21	3	4	56	96.5
	Total	666	241	208	103	69	621	93.2

All the data obtained from the six states were harmonized and subsequently analyzed for the purpose of the current research study.

Table 6 below reveals the descriptive statistics of the responses on perceived legislation.



**Table 6:** Descriptive Statistics of Responses on Perceived Legislation

S/N	ITEMS	Mean(Standard Deviation)
1.	Absence of legal and regulatory systems will affect e-commerce adoption	4.318 (.4660)
2.	Change in regulations with each government will affect e-commerce adoption	5.000 (.4270)
3.	Economic and political instability will affect E-commerce adoption	4.763 (.4250)
4.	Lack of government leadership will affect e-commerce adoption	3.100 (.4564)
5.	Insufficient procedures to ensure compliance with applicable laws and regulations will affect e-commerce adoption	4.459 (.4987)
6.	Lack of policy that adequately address the collection and use of customer personal information as it relates to privacy	4.239 (.4270)
7.	Non provision of comprehensive privacy disclosure to all on-line users will affect e-commerce adoption	4.078 (.2694)
8.	Lack of policies and procedures to describe methods utilized to validate transactions, e-mails and other contractual obligations relating to e-commerce will affect e-commerce adoption	4.378 (.4854)

It is revealed from the table above that the respondents agreed that; absence of legal and regulatory systems will affect e-commerce adoption; economic and political instability will affect e-commerce adoption.

**Table 7:** Descriptive Statistics of Responses on Ecommerce Use

S/N	ITEMS	Mean (Standard Deviation)
1.	There will be continuous use of ecommerce if the organization provides better way of completing ecommerce transaction.	4.442 (.4971)
2.	Current habits of people in Nigeria do not suit online transaction.	2.140 (1.0330)
3.	Ecommerce will be used for transaction if there is adequate protection of customers' information.	4.842 (.3644)
4.	Ecommerce will be used for transactions if the website provides relevant products/services information	5.000 (.4384)
5.	Ecommerce will be used if information is used for the original purpose.	5.000 (.4260)
6.	Ecommerce will be used if there is full knowledge of party that can have access to customers' personal information on the website.	5.000 (.9004)

From the above table, respondents strongly agreed on average with most of the items measuring e-commerce use among the users.

### Test of Hypothesis

**H<sub>01</sub>:** Perceived legislation does not significantly affect the use of e-commerce by customers in Nigeria.

**Table 8:** Hierarchical Regression Result (PELE)

Model	Predictor	Coefficient	Std. Error	P>  t	P-value	R <sup>2</sup>
1 - Item Level	<i>F- Stat</i>				0.0000	0.69
	Pele1	.4982818	.0388395	0.000		
	Pele4	.600907	.0463036	0.000		
	Pele5	.7000958	.0758787	0.000		
	Pele7	1.682522	.065464	0.000		
	Pele8	1.099189	.0652403	0.000		
	_cons	3.662132	.1696141	0.000		
	AIC	104.0663				
	BIC	130.547				
	Breusch-Pagan	230.58			0.1930	
2 - Aggregate Level	<i>F- Stat</i>				0.0000	0.20
	Pelemean	.6042745	.0498776	0.000		
	_cons	6.796403	.2135136	0.000		
	AIC	686.7133				
	BIC	695.5403				
	Breusch-Pagan	112.21			0.3108	

The result in table above revealed that at aggregate level, users' perceived legislation of e-commerce significantly increase the adoption of e-commerce in South-West Nigeria. The R-square of the aggregate model shows less variation (20%) compared to item data level model, however, the aggregate data significantly fit the overall model and as such considered good and adequate. In other words, the result confirms the rejection of the null hypothesis. Lastly, the principle of parsimony suggests that model one is preferred given its better estimates compared to model two although the outcomes of the two models exhibit better fits.

Moreover, SEM was further conducted to be more accurate about impact of user' perceived legislation on acceptance of e-commerce platforms in the study area. SEM has been adjudged

to provide more reliable statistical estimate in measuring cause-effect analysis between two or more complex variables (Hair, Black, Babin, Anderson and Tatham 2006). In other words, the information in Figure 2 reveals the outcome of SEM conducted through STATA to this effect. Contrary to result obtained from regression analysis. Figure 2 reveals that items pele1, pele4, pele7 and pele8 as legislation variables were found significant in explaining e-commerce use in the study area. This may be due to SEM power of estimation characteristics over regression technique.

**Figure 2:** Standardized Coefficients for LEGISLATION Items

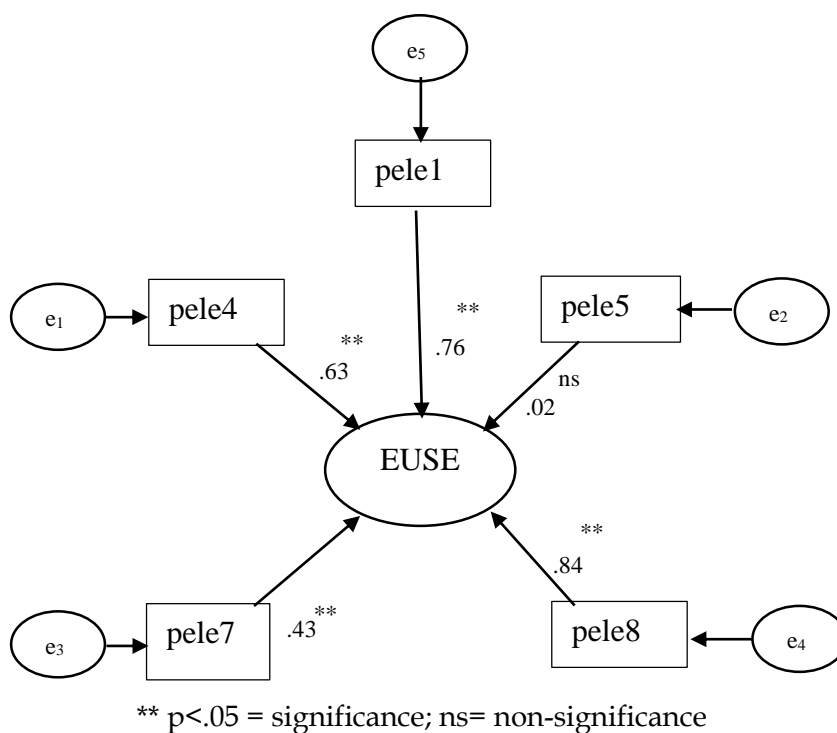

**Conclusion**

The main objective of this study was to determine the role of perceived legislation on the adoption of e-commerce in the South West Nigeria with focus on e-commerce customers in the six states of the South West geo-political zone of Nigeria. From the result of the findings, it is evident that perceived legislation has an important role to play in the adoption and use of e-commerce by customers in Southwest Nigeria.

Lack of government policies and support are major obstacle to the adoption of e-commerce by customers. Government therefore should provide policies and procedures to describe the

techniques utilized to validate transactions, e-mails and other contractual obligations with the view to improving the acceptance and the use of e-commerce.

### **Recommendation**

Based on the findings of the study, the following recommendations are put forward:

- i] There is need for government to formulate friendly policies and maintain stable political environment that will foster e-commerce adoption.
- ii] Similarly, Government should take the role of leadership by helping to create a rather enabling environment in order to develop e-commerce by making the adoption of information and communication technology (ICT) a national priority.

### **References**

- Abdel-Nasser, H. Z. (2012). Barriers to e-commerce adoption in Egyptian SMEs, *International Journal of Information Engineering and Electronic Business* 3 (1) 9-18.
- Abrahamson, E., & Rosenkopf, L. (1993). Institutional and competitive bandwagons: Using mathematical modeling as a tool to explore innovation diffusion, *Academy of Management Review*. 18 (1) 487-517.
- Ackerman, M. S., & Davis, D. T. (2008). *Privacy and Security Issues in e-commerce*. In Jones (ed.) Reviewed Chapter for the New Economy Handbook.
- Adewale, G., Ayo-Oyebiyi, G. T., & Adebayo, S. A. (2013). An Empirical Study of Factors That Influence the Adoption of e-Commerce in Nigerian Business Organizations. *International Journal of Business and Management Invention*, 2 (9) 28-33.
- Agwu, M. E. (2015). Analysis of Obstacles to Uptake of Internet Banking Services in Nigeria, *Research Journal of Business Management*, 2 (1) 99-114.
- Agwu, M. E., & Murray, J. P. (2014). Drivers and Inhibitors to e-Commerce Adoption among SMEs in Nigeria, *Journal of Emerging Trends in Computing and Information Sciences*, 5 (3) 192-198.
- Agwu, M. E. (2012). Generations X and Y's adoption of internet and internet banking in Nigeria: a qualitative study, *International Journal of Online Marketing*. 2 (4) 68-81.
- Ahmed, J. U., & Hasan, H. (2016). Barriers to e-commerce adoption in Syria: An empirical Detection, *World Journal of Business and Management*. 2 (1) 41-56.

- Allen, B., Bresnahan, J., Childers, L., Foster, I., Kandaswamy, G., Kettimuthu, R., Kordas, J., Link, M., Martin, S., Pickett, K., & Tuecke, S. (2012). Software as a service for data scientists, *Communications of the ACM*, 55, 81-88.
- Chaffey, D., Ellis-Chadwick, F., Mayer, R. & Johnston, K. (2009). *Internet marketing, strategy, implementation and practice*, 4th ed. Essex: Pearson Education.
- Chemeke, S.C., Elowekpaefe, A.E., Okpo, J.A. & Irhebhude, M.E. (2014). A framework for electronic commerce adoption: A study in Kaduna State, Nigeria. *Science World Journal*, 9 (3) 23-29.
- Cochran, W.G., (1977). *Sampling techniques*, New York, Wiley: 428.
- Creswell, J. (2009). Editorial: Mapping the field of mixed methods research. *Journal of Mixed Methods Research*, 3 (2) 95-108.
- Dan, O. (2014) Influence of School Feeding Program on Academic Performance of Pre-School Children in Kayole Zone in Nairobi County (Undergraduate Project, University of Nairobi). Retrieved from [https://cees.uonbi.ac.ke/danproject\\_0/2018/1/30](https://cees.uonbi.ac.ke/danproject_0/2018/1/30).
- Efendioglu, A. M., & Yip, V. F. (2004). Chinese Culture and E-commerce: An exploratory study. *Interacting with Computers*, 16(1): 45-62.
- Hair, J., Black, W., Babin, B., Anderson, R., & Tatham, R. (2006). *Multivariate Data Analysis* (6th ed.). Upper Saddle River, NJ: Pearson Education, Inc.
- Haseeb, K., Arshad, M., Ali, S., & Yasin, S. (2011). Secure E-commerce protocol. *International Journal of Computer Science and Security*. 5(1): 742-751.
- Hoffman, D. & Novak, T. (1998). *A New Marketing Paradigm for Electronic Commerce*. The Information Society. 13.
- Jebur, H., Gheysari, H., & Roghanian, P. (2012). E-commerce Reality and Controversial Issue. *International Journal of Fundamental Psychology and Social Sciences*, 2(4): 74-79.
- Kaur, K. (2005). Consumer protection in e-commerce in Malaysia: an overview. *Journal of the UNE Asia Centre*. 10(1): 1-14.

- Kaur, H. & Kaur, D. (2015). E-commerce in India- Challenges and Prospects. *International Journal of Engineering and Techniques*, 1(2): 1-5.
- Kinuthia, J. N., & Akinnusi, D. M. (2014). The magnitude of barriers facing e-commerce businesses in Kenya. *Journal of Internet and Information Systems*, 4(1): 12-27.
- Kraft, T.A., & Kakar, R. (2009). E-commerce security. EDSIG. Washington DC. 1-11.
- Lawrence, J. E. & Tar, U. A. (2010). Barriers to e-commerce in developing countries. *Information Society and Justice*, 3(1): 23-35.
- Maaruf, L. M., & Abdulkadir, K. (2012). An Overview of e-Commerce Implementation in Developed and Developing Country: A Case Study of United States and Nigeria. *International Journal of Modern Engineering Research*, 2(5): 3068-3080.
- Mbarika, V. W., Okoli, C., Byrd, T. A., & Datta, P. (2005). The Neglected Continent of IS Research: A Research Agenda for Sub-Saharan Africa. *Journal of the Association for Information Systems*, 6(5): 130-170.
- Mittal, A. (2013) E-commerce: It's Impact on Consumer Behaviour. *Global Journal of Management and Business Studies*, 3(2): 131-138.
- Odedra-Straub, M. (2003). E-commerce and development: Whose development? *Electronic Journal on Information Systems in Developing Countries*. 11(2): 1-5.
- Oluyinka, S., Shamsuddin, A., Wahab, E., Ajagbe, M. A. & Enegbuna, W. I. (2013). A study of Electronic Commerce Adoption Factors in Nigeria. *International Journal of Information Systems and Change Management*, 6(4): 293-315.
- Rawabdeh, W., Zeglat, D., and Alzawahreh, A. (2012). The importance of trust and security issues in e-commerce adoption in the Arab world. *European Journal of Economics, Finance and Administrative Sciences*. 1(52): 1-7.
- Rehman, S. U., and Alam, R. (2016). A Study of Barriers to e-Commerce Adoption among SMEs in Malaysia. *Modern Science Journal*, 1(1): 45-58.
- Rogers, E. M. (1995). *Diffusion of Innovation*. Free press, New York, NY.
- Smith, R. and Shao, J. (2007). Privacy and E-commerce: a consumer-centric perspective. *Electron Commerce Res.* 7(1): 89-116.

Turban, E., King, D., McKay, J., Lee, J. and Viehland, D. (2008). *Electronic commerce: A managerial perspective*. Prentice Hall. (5th edition).

Vaithanathan, S. (2010). A review of e-commerce literature on India and research agenda for the future. *Electronic Commerce Research*. 10(1):83-97.

## TECHNOLOGICAL INNOVATION AND ORGANIZATIONAL PERFORMANCE

<sup>1</sup>Mukai Aremu Akinde & <sup>2</sup>Yusuf Adebola Bako

<sup>1</sup>Department of Taxation, Federal Polytechnic, Ilaro, Ogun State, Nigeria

<sup>2</sup>Department of Business Administration and Management,  
Federal Polytechnic, Ilaro, Ogun State, Nigeria



### Abstract

*For any organization to succeed, it should be able to compete within its market, and attempt to rub shoulders with other competitors in the international frontiers. The study seeks to investigate the effect of technological innovation of organizational performance of Dangote Plc, Ibesse Plant, Ogun State. The objective of the study was decomposed to find out the impact of Strategic planning capability & Marketing Planning Capability on Organizational Performance. A descriptive survey design was adopted for this study. A sample size of 96 employees in the study area were conveniently selected by the researcher to aid effective result. A structured questionnaire was utilised to collect the needed data from the respondents. The collected data was analysed using simple percentage statistics while the hypotheses were tested using linear regression analysis. The finding of the study revealed that strategic planning capability and marketing capability have positive relationship with organizational performance ( $p= 0.000$ ). Following the findings of the study, it was recommended that there should be pragmatic strategic planning capability in order to deliver superior performance and ultimately sustained competitive advantage.*

**Keywords:** *Innovation, Marketing Planning, Organizational performance, Strategic Planning, Technology*

### Introduction

Technological innovation is more and more important for an organization in a competitive and dynamic environment. Technology, as an intangible asset, is becoming a critical factor for the survival and competition among companies. Zahra & Bogner (2000) suggest that technological innovation may have an impact on the industry's structure or competitive advantage, as well as being an important edge for a company willing to challenge a well-established competitor. Therefore, the widespread application of technology can be an important factor in structuring an industry, technological innovation can provide a competitive advantage for a company or even increase the profitability of all the companies within the industry.



For any organization to succeed, it should be able to compete within its market, and attempt to rub shoulders with other competitors in the international frontiers. The organization must imbibe the culture of innovation because of its importance as confirmed in many studies (Daniels, 2002; Gelende & Fuente, 2003).

Unfortunately, Nigerian manufacturers find it difficult to stand against its competitors from foreign countries. The local companies cannot compete with the foreign counterparts in terms of product quality and other areas of marketing capabilities.

The foreign firms have strategic plan as a tool-kit for achieving their feet, which is also lacking among the domestic manufacturers. The resultant effect is while the local industries performance is on the decline, the multinationals are booming. The broad objective of the study is to evaluate the impact of technological innovation on Organization performance.

In order to pursue the broad objective of this study, the following hypothetical statements are put forward to give a direction to this study:

**H<sub>01</sub>:** Information technology does not have any effect on strategic planning capability

**H<sub>02</sub>:** Product innovation does not have an effect on marketing capabilities.

## **Literature Review**

### **Conceptual Framework**

#### **Technological Innovation Concept and Innovation Process**

Technological innovation is underdetermined – there is no single “best solution”. To state that technological innovation is underdetermined is to say that “technical principles are insufficient by themselves to determine design” Feenberg, (1995). The research traditions mentioned above subscribe to the view that the “natural attributes” of technology are not sufficient to explain technological innovation, though they differ in the importance they attach to this belief. For the social shaping of technology theorists, the belief that technological innovation does not unfold according to some predetermined technical logic is critical (Williams & Edge, 1996). The particular path that technological innovation takes is something to be explained, rather than simply adjusted to. Studies of the management of innovation, and innovation adoption, acknowledge that the seemingly “best” technology does not always become the most widely accepted Utterback, (1994).

While the economists of innovation believe that technological “trajectories” make some innovation paths more likely than others (Dosi, 2005), the complex interplay between technological supply and market demand cannot be captured strictly with reference to the characteristics of technology. Even in the literature on technology and organization structure, which has argued for the strongest links between the nature of technology and organizational

forms, there is a recognition that technological change serves as an occasion for restructuring Barley, (2000), and the same technology can occasion quite different organizational outcomes.

Technological innovation cycles between periods of stability and change. A wide range of technological innovation research suggests that the innovation process fluctuates between periods of relative stability and periods of relative change. Research on innovation and business strategy in particular has argued that the nature of innovation changes over time. Periods of more incremental innovation, in which technology appears to develop along well understood paths, are then abruptly followed by periods of more radical innovation, in which the certainties of the past era are abandoned Utterback, (1994); Tushman & Rosenkopf, (2002).

### **The Meaning and Scope of Organization**

Organization is defined in a number of ways. In the study of management, it can refer to the structure of relationships among individuals. A less static approach defines organization as a process or an element of management concerned with change or growth of the structure. So, organization can be defined as a collection of people working together in a division of labour to achieve a common purpose.

The aim of any organization is to produce a good or service. Large and small businesses produce consumer goods and services such as automobiles, appliances, gourmet dining, and accommodations. Non-profit organizations produce services with public benefits such as health care, education and judicial processing. A clear statement of aim is important to guide the activities of an organization and its members.

To achieve its aims, organizations depend on the activities and collective effort of many people. At this respect, people are the main human resources of organizations - the individuals and groups whose performance contributions make it possible for the organization to serve a particular purpose. However, organizations need more than people if they are to achieve their aims, to survive and prosper. They also need material resources including physical equipment and facilities, technology, information, raw materials and money. Organizations require all of these resources in order to produce some useful goods and services.

### **Organizational Performance**

Measuring organizational performance is difficult (Hubbard, 2009). Numerous literatures exist on organizational performance. The earliest research on this topic developed what was known as the shareholder's theory. They viewed firms as belonging to shareholders and as such, they concluded that organizational performance can be measured only in terms of shareholders' returns. This theory agrees with the belief of Prof Milton Friedman who stated that 'the business of firms is to make profit' (Porter, 1980; Owen, 2006; Brown & Fraser, 2006).

Organization performance has been defined as the capability of firm to accomplish its goals and objectives with the help of talented administration, good governance and have a constant rededication to accomplish business objectives Mahapatro, (2013). Organizational performance is a sign which deal how well a business complete its goals. Organizational performance is one of the most key constructs in the research of management (Ho, 2008).

Owen (2006), in agreeing with the shareholders' theory believes that organizational performance encompasses three specific areas of firm outcome: (a) Financial Performance (profits, return on assets, return on investment etc), (b) Product Market Performance (sales, market share etc.) and (c) Shareholders Returns (total shareholders return, economic value added etc.)

The 1990s saw the emergence of the Stakeholders theory (Hobbar, 2009). This theory sees the firm as responsible not only to shareholders, but also to a wider group which includes employees, representatives, customers, suppliers, government, industries, bodies, local communities etc. As such, its performance must be measured by how much it is able to satisfy these stakeholders (Freeman, 1984; Reich, 1998; Post, Preston, & Sach, (2002); Brown & Fraser, 2006; Steuer, 2006). The stakeholder theory assesses organization performance against the expectation of a variety of stakeholder groups that have particular interest in the effects of the organization's activities. Its perspective of organizational performance incorporates stakeholder value, but recognizes that shareholders are just one group of stakeholder and only relevant to those organizations that issue shares (Hubbard, 2009).

Another concept of organizational performance based on the stakeholders' perspective is the Balanced Score Card (BSC). This incorporates financial, customer/market, short term efficiency and long-term learning and development factors into the measurement of organizational performance.

## **Theoretical Framework**

### **Unified Theory of Acceptance and Use of Technology (UTAUT)**

This study is anchored on the Unified Theory of Acceptance and Use of Technology (UTAUT) posited by Vankatesh, Morris, Davis & Davis (2003). The UTAUT model intends to explain technology acceptance and it is based on eight technology acceptance theories or models. Particularly, the UTAUT extracts from the Theory of Reasoned Action (TRA), the Technology Acceptance Model (TAM), the Motivational Model, the Theory of Planned Behaviour (TPB), the combination of TAM and TPB, the model of Personal Computer Utilization, the Innovation Diffusion Theory and the Social Cognitive Theory (Vankateshet *al.*, 2003). Centrally, the UTAUT model uses behavioural intention as a predictor of the technology use behaviour. The

behavioural intention predictors that are included are based on the components of the eight technology adoption models reviewed.

Adding to behavioural intention and use behaviour, the UTAUT model comprise of four constructs which are performance expectancy, effort expectancy, social factors and facilitating conditions. The model also includes four moderating variables: age, gender, education and voluntaries of use. In the model, performance expectancy and effort expectancy and social factors directly affects behavioural intention which along with facilitating directly affects use behaviour.

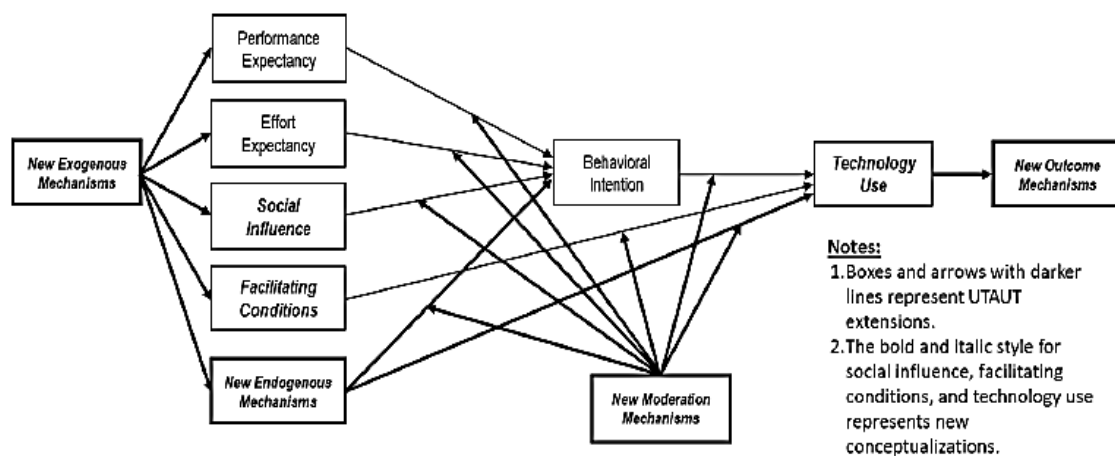

**Source:** Venkatesh et al. (2003)

### Empirical Framework

Empirical evidence which connects innovation with organizational outcomes such as financial performance abounds in literature. In the study of a business operating in Istanbul, Turkey, Gokmen and Hamsioglu (2011) discovered the existence of a relationship between innovation and organizational performance. Lim, Schultmann and Ofori (2010) studied the effect of innovation on performance of construction firms using data statistical data across 18 Organization for Economic Cooperation and Development (OECD) countries and expert interviews in Singapore. They discovered that due to the fact that construction projects are awarded by clients based on lowest cost, innovation appears to be an unfeasible competitive strategy. However, their study revealed that construction firms can develop their competitive advantage through manipulating innovations that consumers are willing to pay for and innovations that would reduce construction costs. They also recommended that construction firms first utilize quality improvements to exploit consumers' willingness to pay for innovative products. This initiative would enable construction firms to improve their finances for innovation and develop their "brand" in construction products. Sustainable competitive

advantage could then be firmly established when construction firms engage in productivity improvements that lead to lower construction costs and/or faster completion times.

Yam, Guan, Pun and Tang (2004) state that technological innovation is the skill involved in realizing and supporting a company's technological innovation strategy. As such, it is a specific asset or resource which includes technology, products, expenditures, processes, knowledge and experience. In their study, they also propose seven dimensions for measuring technological innovation which are: technological learning, R and D, resource allocation, manufacturing ability, marketing skill, organizational skill, and strategic and scale related ability. Archibugi & Coco (2005) point out that technological innovation is the ability to access and digest external knowledge into some unique skill or knowledge, then using it in a dynamic way to improve or develop a new product and launch it successfully. Therefore, it includes capability in product, process and personnel technology.

### **Methodology**

The study adopted a survey research design which measured two variables, dependent and independent variables. The independent variable is technological innovation which was measured by sub-variables information technology and product innovation while the dependent variable organizational performance was measured by strategic planning capability and marketing capability.

The population of the study is the management staff of Dangote Plc (Ibese branch) which consists of 448 staffs which include the top management staff, senior staff and junior staff.

The sample size was calculated using the sample size determination for research activity by Taro Yamane. In estimating the sample size, a 5% margin of error (confidence interval) was used. The sample size for the study therefore is ninety six (96). The next question borders on how the researcher will select 96 management staff out of the population. This question leads us to sample selection method appropriate for this study with respect to selecting the management staff. In this study the probability (or random) sample shall be used because we want every unit (that is management staff) of the study population to be given an equal chance and known probability of being represented in the sample.

The data for the study were collected using both primary and secondary source of data. Primary source of data involve the use of questionnaire, some secondary sources data which include textbooks, journals and online article were also consulted during the literature review. The copies of the questionnaire were distributed to the management staff and the information so collected formed the thrust of the data analysis. Content validity was used for the current study. Cronbach's alpha method of reliability is used for measuring the reliability of this research work. Descriptive statistics which involves the collection, presentation and

characterization of a set of data in order to properly describe the various features of that set of data was employed. Hence extensive use of percentages was made.

Also, simple linear and multiple regression analysis in respect to the study hypothesis were used to measure the degree of effects of independent variables on the dependent or outcome variables. After distributing the questionnaire, data would be collected, coded and analyzed through the use of the Statistical Package for Social Science (SPSS). Regression analysis and descriptive statistics would be used to validate the data.

## Results and Discussion

**Table 1:** Reliability Statistics

Cronbach's Alpha	N of Items
.738	18

**Source:** Researcher's Compilation from SPSS

The Cronbach alpha reliability test shows the result of the reliability test of the responses of the respondents to the returned questionnaire, the result shows the Cronbach alpha value of 0.738 which indicates that the respondents responses is highly reliable.

**Table 2:** Model Summary<sup>b</sup>

Model	R	R Square	Adjusted R Square	Std. Error of the Estimate	Durbin-Watson
1	.400 <sup>a</sup>	.160	.142	.67309	1.911

a. Predictors: (Constant), Product Innovation, Information Technology

b. Dependent Variable: Organizational Performance

**Source:** Researcher's Compilation from SPSS

The table above shows the R square with the value of .160% which indicates that 16.0% variation in organizational performance is caused by the explanatory variables which include Product innovation and Information technology. Also, the adjusted R square indicates that after adjusting the degree of freedom, the explanatory variables can still explain 14.2% variation in the organizational performance. However, the table further reveals the Durbin Watson statistic with the value of 1.911 which indicates that there is no serial auto correlation among the variables.

**Table 3:** ANOVA<sup>a</sup>

Model		Sum of Squares	Df	Mean Square	F	Sig.
1	Regression	8.022	2	4.011	8.854	.000 <sup>b</sup>
	Residual	42.134	93	.453		
	Total	50.156	95			

a. Dependent Variable: Organizational Performance

b. Predictors: (Constant), Product Innovation, Information Technology

**Source:** Researcher's Compilation from SPSS

The F statistic table reveals the overall significance of the model, the probability value of 0.000 which is below the level of significance indicate that we reject null hypothesis and conclude that technological innovation has significant impact on organizational performance

**Table 4:** Coefficients<sup>a</sup>

Model		Unstandardized Coefficients		Standardized Coefficients	T	Sig.
		B	Std. Error	Beta		
1	(Constant)	1.115	.300		3.713	.000
	Information Technology	.405	.097	.399	4.190	.000
	Product Innovation	.050	.093	.051	.540	.591

a. Dependent Variable: Organizational Performance

**Source:** Researcher's Compilation from SPSS

The coefficient table reveals the relationship between the variables which shows that the variables have a positive relationship with organizational performance with 0.405 and 0.050. The table further reveals the significance of the explanatory variables which was however used to test the hypotheses of the study. However, the table reveals that information technology is statistically significant with probability value of 0.000 while product innovation is not significant with probability value of 0.591 with organizational performance at 5% level of significance.

**Table 5: Coefficients<sup>a</sup>**

Model	Unstandardized Coefficients		Standardized Coefficients	T	Sig.
	B	Std. Error	Beta		
1 (Constant)	1.549	.275		5.634	.000
Information Technology	.195	.121	.164	1.607	.111

a. Dependent Variable: Strategic Capability

**Source:** Researcher's Compilation from SPSS

The table above reveals the significant of the variable as well as the relationship between the dependent variable and the predictor. The coefficient result shows that information technology has a positive relationship with strategic capability with the value of 0.195. The significance value of information technology at 0.111 corroborates the conclusion that information technology does not have a significant effect on strategic planning capability employed by organizations.

**Table 6: Coefficients<sup>a</sup>**

Model	Unstandardized Coefficients		Standardized Coefficients	t	Sig.
	B	Std. Error	Beta		
1 (Constant)	1.457	.234		6.231	.000
Product Innovation	.314	.104	.298	3.024	.003

a. Dependent Variable: Marketing Capability

**Source:** Researcher's Compilation from SPSS

The table above reveals the significant of the variable as well as the relationship between the dependent variable and the predictor. The coefficient result shows that product innovation has a positive relationship with marketing capability with the value of 0.314. The significance value of product innovation at 0.003 corroborates the conclusion that product innovation has a significant effect on marketing capability employed by organizations.



**Table 7: Correlations**

		Information Technology	Marketing Capability	Product Innovation	Strategic Capability
Information Technology	Pearson Correlation	1	.302**	-.037	.164
	Sig. (2-tailed)		.003	.720	.111
	N	96	96	96	96
Marketing Capability	Pearson Correlation	.302**	1	.298**	.242*
	Sig. (2-tailed)	.003		.003	.017
	N	96	96	96	96
Product Innovation	Pearson Correlation	-.037	.298**	1	-.094
	Sig. (2-tailed)	.720	.003		.365
	N	96	96	96	96
Strategic Capability	Pearson Correlation	.164	.242*	-.094	1
	Sig. (2-tailed)	.111	.017	.365	
	N	96	96	96	96

\*\* . Correlation is significant at the 0.01 level (2-tailed).

\* . Correlation is significant at the 0.05 level (2-tailed).

**Source:** Researcher's Compilation from SPSS

The correlation table shows the relationship between the variables. However, the table shows that information technology has a positive correlation with marketing capability and also statistically significant at 0.05 level of significance. Also, the table reveals that information technology with 0.037 has a negative relationship with product innovation and not statistically significant at 0.05 level of significance. The table further reveals that information technology has a positive but low correlation with strategic planning capability and also not statistically significant at 5% level of significance. Also, marketing capability has a positive relationship with product innovation and also statistically significant with probability value of 0.003. Furthermore, marketing capability has a positive relationship with strategic capability but not statistically significant. Finally, the table shows that product innovation has a weak negative relationship with strategic capability and also not statistically significant with significance value of 0.365.

## **Test of Hypotheses**

### **Hypothesis I:**

H<sub>0</sub>: Information technology does not have any effect on strategic planning capability

**Decision Rule:** The coefficient table shows that strategic capability and marketing capability with probability value of 0.111 is not statistically significant which denote that we accept null hypothesis and conclude that Information technology does not have any significant effect on strategic planning capability.

### **Hypothesis II:**

H<sub>0</sub>: Product innovation does not have an effect on marketing capabilities.

**Decision Rule:** Product innovation with probability value of 0.003 is statistically significant which means that we reject null hypothesis and conclude that product innovation has a significant effect on marketing capabilities.

## **Conclusion**

This research work examined the extent to which technological innovation affect organizational performance in manufacturing industries with particular focus on Dangote Cement Plc. The findings of the study revealed that the explanatory variables which include information technology and product innovation have positive relationship with organizational performance. The research conclude that there is need for high usage of information technology in order to increase the performance of an organization. Similarly, product innovation has to be increased in an organization in order to enhance performance.

Finally, the explanatory variables which include information technology and product innovation used to measure technological innovation while strategic planning capability and marketing capability which was used to measure organizational performance reveals that there is positive relationship among the variables at a significance level of 0.05. Thus, the study corroborates the assertion that there is need for technological innovation (which serves as a driving force) in an organization.

## **Recommendations**

Based on the above findings, the following recommendations are discernible:

- i. Manufacturers should be innovative about their technology so that they can be competitive in the market.
- ii. Organizations should train and re-train their employees so that they can master new innovation in order to be more productive, which will lead to better performance.
- iii. There should be pragmatic strategic planning capability in order to deliver superior performance and ultimately sustained competitive advantage.

- iv. The management of Dangote Plc should embrace marketing capability that can help in the effective and efficient management of marketing mix.

### References

- Archibugi, D., & Coco, A. (2005). Measuring technological capabilities at the country level: A survey and a menu for choice. *Research Policy*, 34, 175-194.
- Barley, S. R. (2000). The alignment of technology and structure through roles and networks. *Administrative Science Quarterly*, (35), 61-103.
- Brown, J., & Fraser, M., (2006). approaches and perspectives in environmental accounting: An overview of the Conceptual Landscape. *Business Strategy and the Environment* (15), 103 - 117.
- Daniels, E (2002). The dynamic of product innovation and firm competences, *Strategic Management Journal*, 23, 1095-1125.
- Dosi, G. (2005). technological paradigms and technological trajectories: A suggested interpretation of the determinants and directions of technical change. *Research Policy*, 11, 147-162.
- Feenberg, A. (1995). *Alternative modernity: The technical turn in philosophy and social theory*. University of California Press, Berkeley, CA.
- Freeman, A. (1984). *Strategic management: A stakeholder approach*. Pitman: Bolton, M. A.
- Galende, J., & Fuente J.M. (2003). Internal factors determining a firm's innovative behaviour, *Research Policy*, (32), 715-736.
- Gokman, A. & Hansioglu, A. B. (2011). Tacit knowledge and its correlation to innovation and performance in obtaining competitive advantage: A Study in a business operating in the Textile Industry, *International Journal of Economics and Administrative Studies*. 4 (7), 19 - 34.
- Ho, L.A. (2008). What affects organizational performance? The linking of learning and knowledge management. *Industrial Management & Data Systems*, 108 (9), 1234 - 1254.
- Hubbard, G. (2009). Measuring Organisational Performance: Beyond the Triple Bottom-line. *Business Strategy and the Environment* .(18), 177 - 191.

- Lim, J.N, Schultmann, F. & Ofori, G. (2010) Tailoring Competitive Advantage Derived from the Needs of Construction Firms. *Journal of Construction Engineering and Management*. 568 – 580.
- Mahapatro, B. B. (2013). Organizational performance. *Human Resource Management*, 272- 279.
- Owen, D. (2006). Emerging Issues in Sustainable Reporting, *Business Strategy and the Environment* (15), 241 – 218.
- Porter, M. (1980). *Competitive Strategy*, Freeman Press, New York .
- Post, J., Preston, C., & Sach, S. (2002). *Redefining the corporation: Stakeholder Management and Organisational Wealth*. Stanford University Press, Pato Alto.
- Reich, R. (1998). The new meaning of corporate fiscal responsibility, *California Management Review* 40 (2), 8 – 17.
- Steuer, R. (2006). Mapping Stakeholder theory Anew: From the stakeholder theory of the firm to three perspectives of business-society relation. *Business Strategy and the Environment* 32 (15), 55 – 59.
- Tushman, M.L., & Rosenkopf, L. (2002). Organizational determinants of technological change: Towards a Sociology of Technological Evolution. *Research in Organizational Behavior*.6 (14), 311-347.
- Utterback, J. M., (1994). *Mastering the dynamics of innovation*, Harvard Business School Press, Boston, MA.
- Venkatesh, V., Thong, Y., & Xu, X. (2012). Consumer acceptance and use of information technology: extending the Unified Theory of Acceptance and Use of Technology (UTAUT). *MIS Quarterly*, 36 (1).157-178.
- Williams, R. E., (1996). *The Social Shaping of Technology"*, in Dutton, W (3<sup>rd</sup>eds), *Information and Communication Technologies: Visions and Realities*. Oxford University Press, New York, NY.
- Yam, C. M., Guan, J. C., Pun, K. F., & Tan, P. Y. (2004). An audit of technological innovation capabilities in Chinese firms: Some empirical finding in Beijing, China. *Res. Policy*, 21(33), 1123-1140.

Zahra, S. A., & Bogner, W. C. (2000). Technology strategy and new venture performance: Examining the moderating role of the firm's competitive environment. *J. Bus. Venture*, 6 (15), 135-173.

## SOCIO-CULTURAL AND ECONOMIC CHALLENGES OF GLOBALIZATION ON THE NIGERIAN SOCIAL STRUCTURE AND WAY FORWARD FOR SUSTAINABLE DEVELOPMENT

**Abubakar Aminu Boyi**

*Department of Sociology*

*Usmanu Danfodiyo University, Sokoto - Nigeria*



### **Abstract**

*The article which is on the Socio-Cultural and Economic Challenges of Globalization on the Nigerian Social Structure attempts to make an x-ray analysis on a number of factors which are considered as hindrances to the attainment of sustainable in Nigeria. To begin with, the concepts of globalization, sustainable development and the dimensions of globalization have been elucidated in the article. The article also identified the socio-cultural and economic challenges of globalization on the Nigerian social structure. Some of the challenges discussed were widening the gap between Nigeria and advanced nations, marginalization, dependence on raw materials, privatization, the removal of subsidy, the reduction of sovereignty, change in the norms and values, the change in the nature of food, the language and also the change in the mode of dressing. Furthermore, the article suggested a possible scenario for the attainment of sustainable development. It was recommended that the government in Nigeria should intensify more research on science and technology, more workshops on the importance of the Nigerian indigenous cultures should be organized, the government should intensify the application of managerial know-how, the government should also be risk bearing and make effective utilization of the country's natural resources. Lastly, there should be a political stability in Nigeria so that sustainable development can be attained.*

**Keywords:** *Globalization, Sustainable Development, Socio-Cultural and Economic Challenges, Nigerian Social Structure, Recommendations.*

### **Introduction**

As the world is now continuously becoming a global village which is looked at as a single community that is connected by highly sophisticated electronic communications systems, more and more nations and countries are assiduously and adequately preparing to maintain strong socio cultural, political and economic ties for their development. This also vividly indicates that the globalization process easily and smoothly operates all around the world. It can be clearly understood that both the developed (industrialized) and the developing (third

world) countries are now working harmoniously together in order to maintain mutual relationships which as a result of that, the developing countries such as Nigeria, for example, are seriously at disadvantaged due to low technical knowhow and managerial skills. This also implies that the level of scientific and technological development is considerably low in the country and in addition, the managerial knowledge to be utilized in other activities most particularly in the international scene cannot adequately assist Nigeria to prosper and develop.

Basically, there are some factors responsible for global. Interdependence, but within the context of this article the factors are the information technology and trade. The information, technology connotes the sharing of ideas or interactions among different countries or nations of the world and it involves the utilization of different electronic means of communication which comprise the internet, radios, televisions, GSM phones etc. According to Olarinsola (2007), communication is interaction in one form or the other either by visual or auditory symbols. This is further buttressed by the fact that numerous people are now continually interacting with themselves and with their environments by talking to their friends, watching television, listening to radios, reading printing text calling or sending away domestic or other animals (Onasanya, Fakomoghon, Shehuand Sodan, 2010). It should therefore be understood here that, the people find it easy to interact or communicate or do their business transactions in different parts of the world and they also do that with the help of information technology. The second factor responsible for global interdependence of countries or nations of the world is the trade. The trade simply refers to the buying and selling of goods and services and it adequately provides an opportunity for global integration of business transactions and capital flows in different parts of the world. This also entails that the role of financial markets in the process of globalization is fundamentally important because the financial markets means gains for private capital which can now flow around the world in search of highest returns (kwanashie, 1998). It is pertinent to note that the developed and developing countries of the world play prominent roles in the business transactions and the developed countries here include England, France, Germany, Italy, USA, Japan, China and the rest while the developing countries are mainly the African, Asian and Latin American countries (Ogunbameru and Rotimi, 2006).

### **Conceptual Framework**

To simply gain a clearer understanding of this paper, there are some concepts which are very significant and they need to be conceptualized for clarifications.

### **Concept of Globalization**

There used to be several definitions given by scholars from different perspectives with regard to the concept of globalization. Globalization can be literally defined as the intensification of worldwide social relations, which link distant localities in such a way that local happenings

are shaped by events occurring many miles away and vice versa (Giddens, 1997). The concept of globalization can also be referred to all those processes through which the peoples of the world are incorporated into a single society – a global society (Albow, 1990). Globalization can be perceived as a process of integrating economic decisions making such as the consumption, investment and saving process all across the world (Ogunbameru and Rotimi, 2006). However, any process of creating a global market place in which increasingly all nations are forced to participate can also be referred to as a globalization (Olayode, 2006). It should be noted that the key elements of this process are the interconnection of sovereign nations, through which trade and capital flows, harmonization of the economic rules that govern relationships between these sovereign nations, creating a structure to support and facilitate dependence and interconnection and creation of a global market place (McGrew, 1992).

From the foregoing it can therefore be asserted that globalization is all about the various kinds of socio cultural, political, economic as well as even the religious relationships take place among numerous nations and countries of the world for easy understanding, progress and development. The relationships are also between the developed and developing nations of the world.

### **Concept of Sustainable Development**

The concept of sustainable development has been defined by the Brundtland commission (1987) as the “development that meets the needs of the present without compromising the ability of the future generations to meet their own needs”. Sustainable Development was also defined by Munasinghe (2004) as the process of improving the range of opportunities that will enable individual humans and communities to achieve their aspiration and full potentials over sustained period of time while maintaining resilience of economic, social and environmental systems. It is therefore, worthy of note that the rationale behind the maintenance of solid socio cultural, political and economic relationships among the various nations and countries of the world is purposely for the attainment of an indispensable sustainable development that is capable of eradicating or minimizing, substantially the challenges of development.

### **Dimensions of globalization**

According to Giddens (1997), there are basically four (4) fundamental dimensions of globalization which make up the world system and give it its basic institutional shape. The following are the dimensions of globalization.

#### **Nation states**

A nation is a group of people with the same language, culture and history who live in a particular area under one government. Nigeria, for example, is a nation. Numerous nation states are now participating in the process of global political order and the states are the principal actors within the global political order and the large business companies are the



dominant agents within the world economy. The business of their activities depends on the profit for profit and the states derive their power from sovereign capabilities (Morgenthau, 1960). However, they do not operate as economic machines, but as actors who are jealous of their territorial rights, concerned with fostering of national cultures and having strategic geo-political involvement with other state or alliances of states.

### **World Capitalist Economy**

A capitalist economy normally is an economy whereby the means of production such as land, labour and capital are owned and controlled by the private individuals and the global interdependence of countries is operated under the capitalist system. The main centers of power in the world economy are the capitalist states, that is the states in which the capitalist economic enterprise is the chief form and international economic policies of these states involve many forms of regulations of economic activity, but as noted their institutional organization maintains on insulation of the economic from the political (Ogunbameru and Rotimi, 2006).

### **World Military Power**

This is the third dimension of globalization. It has been noted that the global interdependence of countries or the nation states ginger them to gain the military power which is fundamentally important in giving them protection. The globalization of the military power is obviously between the armed forces of different states; it also concerns war itself where the participants are drawn from virtually all regions of the world so that they can ensure the maintenance of peace, stability, progress and development.

### **International Division of Labour**

This is the fourth dimensions of globalization. Researchers indicated that there is now the expansion of global division of labour between more and less industrialized areas in the world and the international division of labour is also concerned with the industrial production where different kinds of goods and service are produced. However, as a result of that, more employment or job opportunities are adequately created to the people (Riggs, 2010, Scholte, 2000).

### **Socio Cultural and Economic Challenges of Globalization on the Nigerian Social Structure**

The Nigerian social structure is characterized by some socio cultural and economic challenges which are adversely posing threats to the future Sustainable Development of the country and the following are the challenges:

### **Globalization Widens Gap between Nigeria and Rich Nations**

Many researchers indicated that the globalization processes have deeply widened the gap between the haves and have not that is to indicate the rich nations which are popularly referred to as the scientifically and technologically or the industrially advanced nations and also the countries such as Nigeria which are the developing or the less industrially developed nations of the world (Hurrell and Wood, 1996). As a result of the intense gap between Nigeria and western countries such as USA, England, France, Germany etc., many challenges are occurring in the country such as corruption, unemployment the decay of the local industries and other socio-cultural and economic challenges of Sustainable Development (Olayode, 2000)

### **Marginalization**

As a result of the global interdependence and relationships of Nigeria and the industrially advanced countries, the country is adversely suffering from marginalization which seriously occurs due to some factors. The first factor is poor technological development which implies that the level of scientific and technological advancement in Nigeria is extremely very low considering the fact that the country is not capable of producing heavy capital goods such as machineries that could be adequately utilized for industrial development. The second factor is poor managerial knowhow. Nigeria is abundantly blessed with numerous intellectual resources such as the engineering talents, the technocrats and others but the poor managerial knowhow has become a clog in the wheels of attaining a prosperous industrial development in the country (Anao, 2002)

### **Nigeria's Dependence On Raw Materials**

In the global international market, Nigeria is a producer of raw materials from her agricultural and the solid mineral resources e.g cocoa, cotton, palm oil, crude oil etc. but the challenge is that the country does not substantially benefit in the exportation of all those raw materials and as a result of that, Nigeria cannot adequately develop an independent, self reliant and self sustaining economy that can boost socio-cultural and economic opportunities of sustainable development (Ogude, 2000). It should be noted that most of the challenges of social security that the country is facing today are as a result of the inability of developing a self reliant and self sustaining economy.

### **The Global Impact of Privatization In Nigeria**

Numerous literatures indicated that the privatization of public enterprises in Nigeria such as NEPA, NITEL, NIPOST etc. had contributed in no small measure in bringing about huge losses of jobs which made numerous masses to be redundant in the country. The situation also made the Nigerians to lose their jobs leading to notorious criminal activities. However, Adewumi (2001) opined that the globalization constitutes the most potent threat to the well being of developing countries in general and the working people in particular.

### **Removal of Subsidy as a Challenge**

The removal of subsidy is also one of the challenges of globalization and it hinders the attainment of sustainable development in the country. According to Man (2003), the removal of subsidy in Nigeria created two major challenges which were poverty and high cost of living which all made the lives of the masses deplorable. There are millions of Nigerians that are living in object poverty because they could not cater for their needs to sustain food, shelter and clothing and also lack the accessibility to education which is a weapon of liberation from ignorance, poverty and diseases and also a tool for sustainable development. However, as a result of globalization, the removal of subsidy resulted in the high cost of food and accommodation in most of the Nigerian towns and cities where the unemployment and other social problems are very prevalent. This is further buttressed by Ilo (2003) that the continuous trade and capital liberalization led to growth of informal sector which engaged workers under wrong employment practices like the casual contract employment and deplorable working conditions and environment. Furthermore, the inability of labour to flow/migrate to another part of the world for improved standard of living as part of components of globalization has further worsened the labour situation.

### **Reduction of the Sovereignty of Nigeria**

Within the context of this article, the concept of sovereignty refers to the state or condition of being politically independent. Sovereignty is also one of the features of a state because there is no geographical area or territory that can be considered as a state without being sovereign. As a result of the global interdependence and interaction, the sovereignty of most of the states particularly Nigeria has been eroded by the multi functional companies of the world. It should be noted that the incapability of Nigeria to substantially gain from global internationalization is limited by some factors such as poor domestic management of the economy, the inherent structural contradictions of the economy and some policies of the western industrial countries coupled with the state of technological backwardness which made Nigeria to vulnerably rely on the foreign supply of industrial inputs capital equipment, raw materials, spare parts and other intermediate materials (Sivandan, 1999).

### **Change in the Nigerian Norms and Values**

The norms and values simply refer to the rules and regulations of a society which all the members are anticipated to comply so that social control and conformity can be ascertained. As a result of globalization, the norms and values of Nigeria are currently changing in a negative manner. The values are now daily defined and sold to the Third World via media like internet and satellite television where the Nigerian family responsibilities and care are considerably reduced to the consumption of Junk food Mr. Bigg's chicken George etc. and in addition, there is also the buying of videos cassettes and C.D plates which has all become the order of the day in different nooks and crannies of the country (Alubo, 2002)

### **Changing Nature of Food in Nigeria**

This is also part of the challenges of globalization on the Nigerian social structure. Researches indicated that the Nigerian diets which are, rich in fiber and other natural ingredients have been replaced by the fast foods which are now sold in the expensive food and snacks stores by the hawkers in the traffic and also the food are served complete with coca cola and other forms of soft drinks in the towns and cities. In addition, there are the deluxe restaurants where various kinds of imported drinks such as the Five Alive juices are served with the meals which as a result of that, there are many Nigerians that begin to forget about their traditional food such as Amala, Eba and others (Alubo, 2002) (Lar, 2001)

### **Language**

Language is one of the challenges of globalization on the Nigerian social structure and this is in view of the fact that it has now been discovered that the slangs and the languages of the "Ghettos" are very fast becoming popular most particularly among the youth and the students in most of the Nigerian university campuses, a behavior which is considered very unpleasant as it becomes a cultural erosion. The globalized language is also complicated with the confusion of many Nigerian youth who do not have the capacity of speaking their indigenous languages very fluently (Alubo, 2002) , (Abdullahi, 2004)

### **Mode of Dressing**

This is also another factor which constitutes a serious challenge of globalization on the Nigerian social structure. As a result of globalization, many Nigerian youth and students are now dressing in a manner that is not socially approved and recognized by the society and some of the indecent dressings used by the youth are the Jeans, T-shirts, and Designer Shoes which are also given different names as Kelvin, Versace, St. Micheals and the others. However, the indecent dressings which are used by the Nigerian youth especially the girls and women exposed them to different forms of sexual harassment which are also social problems that deter the progress and development of the Nigerian societies (Alubo, 2002)

### **Conclusion**

It can be clearly understood that the contemporary era of globalization produces numerous socio cultural and economic challenges on the Nigerian social structure and the challenges also adversely hinder the attainment of sustainable development in the country. The paper vividly highlighted on the challenges such as widening the gap between Nigeria and the industrially advanced countries of the world, the marginalization of Nigeria in the global international system, the Nigeria's dependence on raw materials, the global impact of privatization in Nigeria and also the removal of the subsidy as a challenge. However, the other challenges elucidated in the article were the reduction sovereignty of Nigeria, the change in the Nigerian norms and values, the changing nature of food in Nigeria, the languages and finally the mode of dressing as challenges of globalization on the Nigerian social structure.

Therefore, the only way out is for the Nigerian leaders and followers to devote their times, energies and also sink all their religious and ethnic differences in the struggle of the attainment of socio economic independence and sustainable development.

### **Recommendations for Sustainable Development in Nigeria**

Based on all the findings and discussions of the article, the following are some of the recommendations for the attainment of sustainable development in the country:

1. There is the need for the intensification of research on science and technology in Nigeria and this means the Federal Government should adequately mobilize resources in order to support the universities and other scientific research institutes so that they can sufficiently contribute their own quota. With that, the sustainable development can be prosperously attained.
2. The government should continue to organize workshops or public enlightenment campaigns on the importance or preference of the Nigerian indigenous cultures and here, the sociologists, anthropologists and other personalities with the knowledge of culture can contribute in no small measure in mobilizing the masses towards the attainment of sustainable development in Nigeria.
3. In Nigeria, the application of managerial know-how is something that is fundamentally significant. The government should therefore, continue to adequately inject more funds on the acquisition of managerial skills by its citizenry so that the potential managers and technocrats can be produced in such a manner that they can contribute to the attainment of sustainable development in the country.
4. In the contemporary globalization era, there is the need for risk bearing in Nigeria. This means that the government should never relent on the pursuance of its laudable and potential national capital projects in the attainment of sustainable development.
5. Another interesting issue is the efficient and effective utilization of natural resources of Nigeria. The government, therefore, should put much emphasis on the proper utilization of the abundant natural resources of Nigeria such as the human, agricultural, solid mineral water and atmospheric resources towards the attainment of sustainable industrial development of the country.
6. However, there is also the need for political stability in Nigeria. It should be noted that all the challenges of globalization on the Nigerian social structure highlighted in the article can only be rectified when there is political stability and for this reason, the government should put in place adequate security measures on Nigerian democracy so that sustainable development can be attained.

## References

- Abdullahi, Y. Z. (2004). Economic and social impacts of globalization on development countries" in Chika U.A. and Abubakar A.S. (2004). *Issues in Economics* Vol.1 UDU, Sokoto: University Press
- Adewumi, F. (2001). *African trade unions and the challenges of globalization*, Discussion Paper for Trade Union, Labour Studies and Human Rights Education Centre, Akure.
- Albrow, M. (1990). *Globalization, knowledge and society*, An Introduction in Albrow, M. and King (eds) London: Sage.
- Alubo, O. (2002). *The social impact of globalization* A Paper presented at 2002 Damina School organized by Centre for Research and Documentation (CRD). August
- Anao, A. R. (2002). Positioning Nigeria for effective response to the challenges of emerging technology and globalization, *Vanguard*, December, 11.
- Bruntdland Commission* (1987). *Development report*, New York: London
- Giddens, A. (1997). *The consequences of modernity*, Cambridge: Polity Press.
- Hurrell and Wood (1995). Globalization and inefficacy" In *Millenium Journal of International Relations* 24 (3)
- Kwanashie, M. (1998). *The concept and process of globalization* CBN Economic and financial Review 36 No. 4 December 1998 pp. 340.
- Lari S. (2001). *Globalization and developing world. the case of Nigeria*, Class News Letter 8(2). *Man Economic Review*, 2001, 2002.
- McGrew, A. (1992). The third word in the new global order" in Tin Allen and Allen Thomas (eds). *Poverty and Development in the 1990s*: Oxford University Press.
- Morgenthau H.J. (1960). *Politics among Nations*. New York: Knopt
- Munasinghe, S. (2004). *Effective instruction through dynamic discipline*, Charles E. Merrill, Ohio,
- Ogude, J.A. (2000). *The Myth of the global village*, The Comet Newspaper, February 2.

Ogunbameru K. A., & Rotimi R.W. (2006). *Man and His Social Environment*. A textbook of Sociology. Ibadan: Spectrum Books.

Olarinsola, E.O. (2007). *Information technology: A Tool for Effective Management in Nigerian Universities*. Edu Focus 1 (1)8087

Olayode, K.O. (2000). Concepts and Issues of globalization in education" and Fadipe, J.O. and Oluchukwu, E.E. (eds). *Educational Planning and Administration in the 21<sup>st</sup> Century*-Ibadan: Daily Graphs.

Onasanya, O. Fakomogbon, A. Shehu, Y. Onasanya, Z. (2010). *Globalization Processes in Nigeria-Ibadan*: Heineman.

Riggs, F. N. (2000). Globalization: Key Concept <http://nawanea/rear/groom.num>

Scholte, J. A. (2000). *Globalization Issues: Globalization - some definitions* [http://www.mred.org.bibuop.org/bibrop/denning.globalization - num](http://www.mred.org.bibuop.org/bibrop/denning.globalization-num)

Sivandan, A. (1999). Globalization and Left" in *Race and Culture* 40 (21).

## CORPORATE GOVERNANCE AND ORGANISATIONAL EFFECTIVENESS IN THE MANUFACTURING INDUSTRY

<sup>1</sup>Bako, Yusuf A. & <sup>2</sup>Olabimtan, Rashidat O.

<sup>1&2</sup>Department of Business Administration and Management,  
Federal Polytechnic, Ilaro, Ogun State



### Abstract

*Corporate governance is a matter of vital concern for all corporations, large or small, publicly traded or privately held. It is a combination of corporate policies and best practices adopted by the corporate bodies to achieve their objectives in relation to their stakeholders. The objective of the study was to investigate the effect of corporate governance on organizational effectiveness. The study adopted a survey research design where data was collected using a structured questionnaire. The study population comprises of 500 of Sona Agro Allied Foods Ltd, Sango Ota, Ogun State. The sample size of 119 respondents was chosen for the study. Data was analyzed through SPSS using Ordinary Least Square (OLS) while the hypotheses were tested using Multiple Regression Analysis. The findings of the study revealed there is a weak positive relationship between all the variables of corporate governance (board size, board composition, governance structure, management compensation structure) and organizational effectiveness. The study recommended that organizations should see corporate governance as a business opportunity that is profitable in the long run, which will give a clearer view of the ultimate goal of organizational success.*

**Keywords:** *Corporate Governance, Organisational Effectiveness, Board Size, Board Composition, Management Compensation Program.*

### Introduction

It has become a worldwide dictum that the quality of corporate governance makes an important difference to the effectiveness and ineffectiveness of organizations. Corporate governance is defined as the way in which companies are directed and controlled in the interest of shareholders and other stakeholders (Agyei-Mensah, 2016). The term corporate governance describes the system by which companies are directed, controlled and made accountable to shareholders and other stakeholders. Broadly speaking corporate governance refers to the organizational governance of a corporation (McGrath & Whitty, 2015), thus, effective corporate governance practice incorporates transparency, openness, accurate reporting and compliance with statutory regulations among others. Historically, antecedents indicate that financial crisis is a direct consequence of lack of good corporate governance in



organizations; invariably one of the sources of instability in the Manufacturing sector is inadequate practice of corporate governance.

### **Statement of Problem**

The challenging task facing policy makers is to design corporate governance frameworks that are secure, of benefit to all shareholders at large and as effective monitor of management whilst preventing them from extracting excessive private benefits of control (Amer, 2014). Mismanagement, bureaucracy, wastage, pilferage incompetence and irresponsibility by directors and employees are the main problems that make organizations fail to achieve their objectives (Adekunle & Aghedo, 2014). Corporate governance has assumed a central place in the continued effort to sanitize corporate reporting and shore up public confidence in achieving stated objectives of organizations around the world. The issue seems to revolve around putting the right rules, regulations and incentives in place to ensure confidentiality and accountability in the management of the affairs of corporate entities. However, organizations plan to improve on the mechanism of corporate governance which will help increase the effectiveness of the organization. This interest appears more appropriate at this time, when business executives and auditors are continually being held to higher standards of accountability. Corporate governance is viewed as an indispensable element of market discipline and this is fueling demands for strong corporate governance mechanisms by investors and other financial market participants (Abdulazeez, Ndibe & Mercy, 2016).

### **Objectives of the Study**

The main objective of this study is to examine the effect of corporate governance on the effectiveness of Sona Agro Allied Foods Ltd.

In order to achieve the broad objective, the following null hypotheses were synthesized:

- H01:** There is no significant relationship between governance structures and organizational effectiveness.
- H02:** There is no significant relationship between management compensation programs and organizational effectiveness.
- H03:** There is no significant relationship between board composition and organizational effectiveness.
- H04:** There is no significant relationship between board size and organizational effectiveness.

### **Conceptual Review**

Corporate governance is the process carried out by the Board of Directors, and its related committees, on behalf of and for the benefit of the company's Shareholders and the other Stakeholders to provide directions, authority and oversights to management. Corporate governance represents methods through which organizations are being administrated, a

structure which the welfare of different parties with vested interests are harmonized, showing group of interaction between a company's administration, its shareholders and other interested parties (Cheema & Din, 2013). This is in a corollary with the argument that change or improvement of corporate governance practices should be consistent with surrounding value and the corporate environment as the context of implementation (Jamal & Waqas, 2018). Organizational governance represents a noteworthy variable that establishes the strength of the organization and the company's capability to live through financial shake-ups and the overall focus of organizational governance has to do with developing reliability, guaranteeing openness and responsibility.

In the last few years, the widespread realization of globalization and privatization has led to exponentially rising businesses across globe and thus inviting tremendous business communities to explore opportunities. Multinational companies with well-established corporate policies have improved the performances of the organizations. Corporate governance encompasses the regulatory paradigms and various management associated roles and responsibilities, organizational structure including functional and non-functional executives, Board of Directors and Stakeholders. It facilitates the operating guidelines that significantly intend to enhance the cumulative business prospects so as to attract stakeholders' trust, long term capital and productivity. As such, Wahyudin & Solikhah (2017) argued that Corporate Governance Perception Index could increase public trust, as well as confidence of investor and creditor to put their money in a company. Particularly, in case of the globalization and the privatization, maintaining optimal corporate governance is compulsory, as it is affected significantly due to numerous internal as well as external attributes. In spite of such globally anticipated and widespread interest, exploring evidence that corporate governance influences firm performance and associated value often remains an open research domain across global economy.

Corporate Governance is a broad concept and not easy to describe due to continuous expansion of the boundaries of the concept. The definition may vary based on the different perspective of researchers. However, some of definitions of Corporate Governance are generally classified into value creation indicates that developing the long term goals for sustainable performance by focusing on the shareholders of the company and value protection which is accomplished through corporate governance (Adekunle & Aghedo, 2014), value protection is based on accountability of managers and protects the interest of both shareholders and stakeholders (Ajagbe & Ismail, 2014). Also, most researchers argue that definition of organizational performance is incorporated with effectiveness and efficiency, Santos & Brito (2012) state "business performance or firm performance is a subset of organizational effectiveness that covers operational and financial outcomes". Organizational effectiveness is a broader construct that captures organizational performance, as

organizational effectiveness is defined as the efficiency with which an organization is able to meet its objectives. This means an organization that produces a desired effect or an organization that is productive without waste. Exploring in depth, Corporate Governance can be stated as the structure as well as the process by which a company is managed with intent to enhance its business prosperity and responsibility, so as to ultimately improve and ensure wealth creation for the allied stakeholders. In general, there are both internal as well as external variables affecting Corporate Governance and amidst those variables; ownership pattern, control structures and the organizational setup do primarily influence the firm performance (Dina, Ivana & Marina, 2014).

Corporate Governance is a broad concept and not easy to describe due to continuous expansion of the boundaries of the concept. The definition may vary based on the different perspective of researchers. However, some of definitions of Corporate Governance are generally classified into value creation indicates that developing the long term goals for sustainable performance by focusing on the shareholders of the company and value protection which is accomplished through corporate governance (Dina, Ivana & Marina, 2014), value protection is based on accountability of managers and protects the interest of both shareholders and stakeholders (Duc & Thuy, 2013). Also, most researchers argue that definition of organizational performance is incorporated with effectiveness and efficiency,

Santos & Brito (2012) state “business performance or firm performance is a subset of organizational effectiveness that covers operational and financial outcomes”. Organizational effectiveness is a broader construct that captures organizational performance, as organizational effectiveness is defined as the efficiency with which an organization is able to meet its objectives. This means an organization that produces a desired effect or an organization that is productive without waste. Exploring in depth, Corporate Governance can be stated as the structure as well as the process by which a company is managed with intent to enhance its business prosperity and responsibility, so as to ultimately improve and ensure wealth creation for the allied stakeholders. In general, there are both internal as well as external variables affecting Corporate Governance and amidst those variables; ownership pattern, control structures and the organizational setup do primarily influence the firm performance (Duc & Thuy, 2013).

**Fig. 1:** Components of Corporate Governance

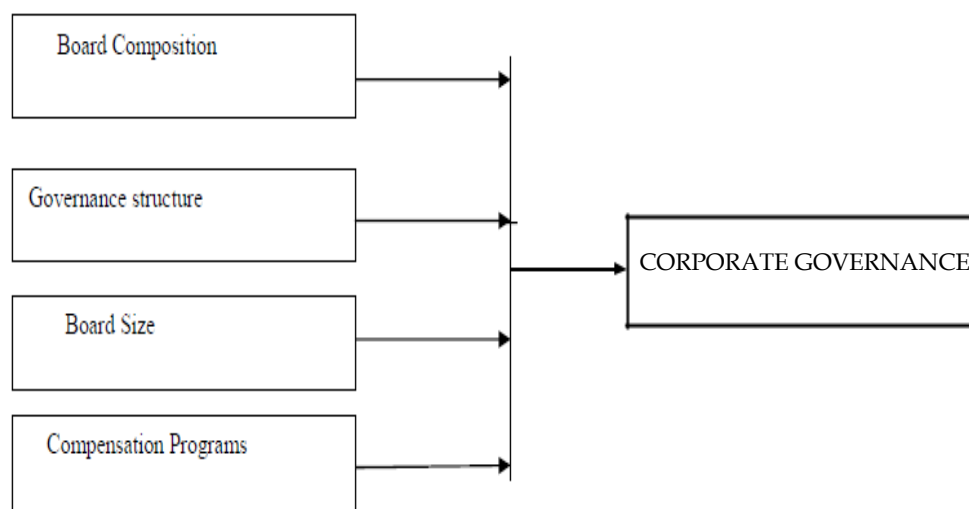

### Corporate Governance

**Components of Corporate Governance (Adopted from Cross, Bazron, Dennis & Isaacs, 1989)**

**Governance Structure:** the board of directors represents the membership of the organization. The board sets in place policies, procedures, values and long term planning to meet the mission of the organization and the board do this through a governance model.

**Board Composition:** it is concerned with issues related to board independence (including independence of board committees), diversity (firm and industry experience, functional backgrounds, etc.) of board members, and CEO duality.

**Compensations Programs:** it is the components of a compensation packages (wages, salaries, and benefits), the manner in which it will be paid, and for what purpose employees receive bonuses, salary increases and incentives.

**Board Size;** it refers to the total number of directors on the board of each sample firm which is inclusive of the CEO and Chairman for each accounting year. Saravanan (2012) research work in India on manufacturing firms shows that size of board and performance has positive significant relationship.

### Relationship between Corporate Governance and Organization Performance

According to the Business Dictionary, performance is the accomplishment of a given task measured against present known standards of accuracy, completeness, cost, and speed. In

contract, performance is deemed to be the fulfillment of an obligation, in a manner that releases the performer from all liabilities under the contract. It connotes successfully outcome and does not just entail putting in some efforts (Fekri, Milad, Hafezali, Alaeddina & Omer, 2016). Performance therefore is a multidimensional construct, the measurement of which varies depending on a variety of factors, according to Bilal, Shahid, Muhammad, Hafiz & Arbab (2013), Firm performance is an important concept that relates to the way and manner in which financial resources available to an organization are judiciously used to achieve the overall corporate objective of an organization, it keeps the organization in business and creates a greater prospect for future opportunities.

Performance management (PM) is a set of activities that ensure goals are met in an effective and efficient manner. Performance management can focus on the performance of an organization, a department, an employee, or the processes in place to manage particular tasks. Performance management standards are generally organized and disseminated by senior leadership at an organization, and by task owners. Performance management is the term used to refer to activities, tools, processes, and programs that companies create or apply to manage the performance of individual employees, teams, departments, and other organizational units within their organizational influence. In contrast, performance appraisal refers to the act of appraising or evaluating performance during a given performance period to determine how well an employee, a vendor or an organizational unit has performed relative to agreed objectives or goals, and this is only one of many important activities within the overall concept of performance management (Fekri, Milad, Hafezali, Alaeddina & Omer, 2016).

At the workplace, performance management is implemented by employees with supervisory roles. Normally, the goal of managing performance is to allow individual employees to find out how well they had performed relative to performance targets or key performance indicators during a specific performance period from their supervisors and managers. Organizations and companies typically manage employee performance over a formal 12-month period (otherwise known as the formal company performance period).

### **Relationship between Corporate Governance and Corporate Image**

In order to understand the influence of the corporate image on the organizations, different views about the essence of this organizational attribute are necessary to be considered. The corporate image can be defined as the sum of impressions that the stakeholders (such as customers, shareholders, suppliers, employees and the society) have about the organization. The good corporate image should be able to align the understanding that the organization has for itself of “who we are”, with the feeling that remains in society with its activities (Erhardt, Werbel & Shrader, 2013). All the positive aspects of the good corporate image can be combined in the concept of “brand equity”, which result in more loyal customers, more productive

workforce and higher profitability. The corporate image is built from positive corporate figures, marketing communications and channels and constant feedback from the public and the stakeholders (Duc & Thuy, 2013).

The positive corporate image provides clean relations between the organization and the stakeholders, recognition from the consumers and increasing loyalty and reputation among the employees. The corporate image becomes a competitive advantage because inherently it builds the image of the brand in the minds of the consumers, which is established over a long period of time and is difficult to be imitated or emulated (Jamal & Waqas, 2018). The positive corporate image can increase the sales and the customer loyalty and can attract new investors and employees that could invest their potential and knowledge in the organization.

### **Relationship between Corporate Governance and Organization Effectiveness**

Organizational effectiveness is the concept of how effective an organization is in achieving the outcomes the organization intends to produce; Jamal and Waqas (2018) reminds us that effectiveness can and must be learned. Organizational Effectiveness groups in organizations directly concern themselves with several key areas, they are talent management, leadership development, organization design and structure, design of measurements and scorecards, implementation of change and transformation, deploying smart processes and smart technology to manage the firms' human capital and the formulation of the broader Human Resources agenda.

### **Corporate Governance and Firm Profitability**

Financial theories on the connection between corporate governance and firm financial profitability are based on equilibrium asset pricing models as well as on the efficient market hypothesis. It predicts three possible relations. One direction of reasoning postulates a neutral relation. It assumes that the risk associated with compliance with Corporate Governance is not priced, therefore all companies Corporate Governance complying as well as non-Corporate Governance complying, have the same rate of expected return and face the same cost of equity capital (Khalid & Muhammad, 2013). This reasoning is in line with standard financial theory (risk-return paradigm) where only risk factors are priced in the market. On the other hand, if the risk associated to Corporate Governance compliance is (correctly) priced by the market, the same risk-return paradigm would imply a negative relation between Corporate Governance and financial performance (Juliet, Aduda, Gituro & Mwangi, 2016).

### **Theoretical Framework**

#### **Agency theory**

Agency theory propounded by Stephen Ross and Barry Mitnick stipulates that the ownership and control of firms are vested in different individuals; there exists a conflict of interest between principal and agent (Juliet, Aduda, Gituro & Mwangi, 2016). According to

Williamson (1975), managers may seek to fulfill their own self-interests as opposed to shareholder's interest or worth. Thus, managers cannot be trusted, even though they are often thought to be rational. In line with this school of thought, Jensen and Meckling (1976) assert that managers do not constantly pursue shareholders interest, and corporate governance is therefore an effective tool in solving the agency problem with the establishment of board.

Agency theory is widely used as a means of explaining various corporate governance issues. The essence of the theory is based on the existence of separation of ownership and control in large corporations. In such corporations, the managers (agents) are hired to work and make decision on behalf of the owners (principals) in order to maximize return to the shareholders. However, conflict of interest between the agent and the principal inevitably occurs when the agent fails to act in the best interest of the principal, and instead act to maximize their own value. Such conflict of interest occurs due to difference in their preferred level of managerial effort, their attitude towards risk, and their time horizons, which in turn may lead to divergence in the goals of managers and shareholders. Consequently, different control mechanisms either internal or external to the firm should be put in place in order to align the interests of managers and shareholders. Nevertheless, argue that, assumptions made in agency theory about individualistic utility motivation resulting in principal-agent interest divergence may not hold for all managers; and therefore, exclusive reliance on agency theory is undesirable, because the theory ignores the complexities of organizational life.

### **Stewardship Theory**

Theodore Roosevelt propounded the stewardship theory. Stewardship theory views manager as the guardian of shareholders' investment and the guardian is taking the companies' assets in order to fulfill their higher needs of achievement and self-actualization (Donaldson & Davis, 1991). The executives of the companies hold a view that they are attached to the existence of companies, and the reputation of companies is also their reputation. Consequently, this perspective viewed that the interests of shareholders and managers are aligned, since there exists insignificant conflict of interest among parties due to the assumption of the theory. The stewardship theory originates from sociology and psychology. The stewardship theory maintains that managers are not motivated by individual goals but rather they are stewards, whose motives are aligned with the objectives of their principals-shareholders; as opposed to the agency theory which claims that conflict of interest between managers and shareholders is inevitable unless appropriate structures of control are put in place to align the interests of managers and shareholders. The stewardship perspective suggests that stewards (managers) are satisfied and motivated when organizational success is attained even at the expense of the stewards' personal goals. Furthermore, while the agency theory suggests that shareholder interests will be protected by separating the posts of board chair and CEO, the stewardship theory argues that shareholder interests will be maximized

by assigning the same person to the posts of board chair and CEO to give more responsibility and autonomy to the CEO as a steward in the organization.

### **The Stakeholder's Theory**

Edward Freeman propounded the stakeholder theory. This theory states that the firm is a system of stakeholders operating within a larger system of the society which provides the required legal and market infrastructure for the firm to thrive. The purpose of the firm in this case is to serve the general public who may have direct or indirect relationship with the firm. The management and the provision of information should be directed at satisfying the interest of the general public rather than shareholders.

### **Empirical Review**

Sicily Gachoki & Gladys Rotich (2013) examined the influence of Corporate Governance on the Performance of Public Organizations a study of Kenya Ports Authority (KPA). Corporate governance in Kenya has been an important topic because of corporate scandals such as the recent complaints on the composition of the board members in the state corporations against the tribal lines basis. Albeit a lot of literatures have drawn much emphasis on the relationship between corporate governance and ownership and on the relationships little is known about the influence of the corporate governance on performance of public organization. The factors considered include; Board composition, Management compensation, Governance structure and Board size. Out of the four variables studied it was found that the board composition had a greater influence on the performance of public organizations.

Danquah, Gyimah, Afriyie and Asiamah (2018) studied the relationship between corporate governance and firm performance an empirical analysis of some listed manufacturing firm in Ghana. Specifically, the paper investigated whether gender diversity, board independence, and board size affect return on asset (ROA) and return on equity (ROE). The results showed that board independence and return on equity (ROE) have positive significant relationship at 1 percent significance level. Thus, the existence of outside directors in terms of their strict supervision, advice, expertise in financial, legal and other areas and their external influences positively affects the financial performance of manufacturing listed firms in Ghana. This means that as the number of non-executive director's increases, manufacturing firms tend to perform better. The empirical results again showed that gender diversity has a positive significant relationship with ROE at 1 percent significance level. Also, there is no statistical relationship between board size and ROE and there is no link between board size and firm performance. This implies that the size of boards today does not really matter, however the caliber of people on the board is a matter of importance since board independence and gender diversity had a significant influence on the firm performance.



The significance of corporate governance has been argued commonly among public listed firms without paying attention to specific industries. The paper emphasizes on the importance of corporate governance in the manufacturing sector of Ghana. We find that board independence and gender diversity of boards have positive significant effect on the performance of manufacturing listed firms in Ghana. The researchers generally suggested that the implementation of corporate governance principles has some imperative implications for manufacturing firms in Ghana. The study notes that board independence ensures better management practices through boards exerting much needed pressure, greater opportunities, stronger internal auditing, and strategic outlook through external directors.

Williams, Chukwuma and Anthony (2016) the paper examined the impact of corporate governance on performance of manufacturing firms in Nigeria. The empirical findings revealed that Chief Executive Officer Shareholding has a positive and a significant impact on organizational performance at 5% level of significance. Director's shareholding has a negative and a significant impact on organizational performance at 1% level of significance. Board gender has a negative and an insignificant impact on organizational performance at more than 10% level of significance. On the basis of these findings, the study recommended excerpts that increase in Chief Executive Officer Shareholding would significantly improve organizational performance. It was also recommended that increase in Director's Shareholding would significantly lead to a decrease in organizational performance.

Tanko and Kolawole (2015) found out that there was a high relationship between the boards size of the companies used in the study and their performances. On board composition, the study found out that averages of 30 percent of all board members are outsiders which suggested that these boards are relatively not independent. They therefore showed a weak relationship in that direction. The study concluded that the more outsiders there are on a company's board, the better the performance in terms of return on equity. On CEO to serve as the chairman of the company, the study found out that when a CEO also serves as the board chairman performance worsens.

Delima and Regel (2017) provide that board size and code of conduct have not significantly contributed to organizational performance. It can be suggested that board of directors have to concentrate on their roles to lead the organization successfully. Meanwhile, financial institutions have high level of organizational performance. Thus, these institutions have more concentrated on customer satisfaction and employee commitment. But financial institutions fail to concentrate on corporate reputation. Hence, they should focus on risk of investment and also future growth of companies.

**Methodology**

This study adopts quantitative research design under the survey research method. The population of Sona Agro Allied Foods with 502 employees at all the three levels of management including top level, middle level and lower level of management and this was obtained during the collection of information on the number of employees in the organization.

Taro Yamane technique was used to determine the sample size.

$$\text{Thus } n = \frac{N}{1 + N(\epsilon)^2}$$

Where: n = Sample size

- N = Population (502 staffs)
- 1 = Unity (a constant)
- $\epsilon^2$  = level of significance
- $\epsilon$  = 0.07 or 7%

$$n = \frac{502}{1 + 502(0.07)^2}$$

$$n = \frac{502}{1 + 502(0.0049)}$$

$$n = \frac{502}{3.45}$$

$$n = 144.9275$$

Approximately 145

Primary data employed in this study was collected using a structured questionnaire. Secondary data is collected from available books, publications, research studies, articles and internet. multiple regression analysis was used to examine the relationship between corporate governance and organizational effectiveness with the aid of statistical package for social sciences (SPSS).

**Table 1.**

Cronbach's Alpha	Valid Number	Number of Items
0.842	119	20

**Source:** Author's Computation, 2019.

The above shows the reliability of the questionnaire used for the survey research. This shows the Cronbach's alpha of 0.842 which is an indication that the questionnaire used for the research work is highly reliable. Hence further analysis can be done on the result obtained from the field.

## Results and Discussion

**Table 2:** Summary of result of hypotheses

Statistics	Values
Multiple R	0.204
R-squared	0.042
Adjusted R-squared	0.007
F-value	1.213
Standard Error	5.778
p-value	0.009

**Table 3:** Summary of result of hypotheses

Variable	Regression Coefficient	Standard Error	t	Sig
Constant	10.369	1.232	8.416	0.000
GS	0.014	0.106	0.135	0.003
BC	0.017	0.094	0.185	0.004
BZ	0.021	0.049	0.438	0.002
MCP	0.285	0.131	2.170	0.032

Level of significant  $p \leq 0.05$

Source: Author's Computation, 2019.

### **Discussion of Results**

The result of the analysis as indicated in table 4.2.1a shows that there is a weak positive relationship between joint effect of board size, board compensation, governance structure and management compensation programs on organizational effectiveness with regression coefficient of 0.204. Furthermore, it is noticed that about 4.2% variation in organizational effectiveness is attributed to board size, board compensation, and governance structure and management compensation programs. It also revealed that the joint effect of the independent variable will on account for about 0.7% variations in organizational effectiveness with the inclusion of new independent variables. However, the F-value is 5.778 with significant value of  $0.009 < 0.05$  significance level.

Furthermore, the contribution of each independent variable (that is; board size, board composition, and governance structure and management compensation programs) is as indicated in table 4.2.1b above. The gradient of the regression line is 10.369, which is the contribution in the absence of the independent variables to organizational effectiveness. In addition, in the absence of other three independent variables, the regression estimate for governance structure is 0.014 with standard error of 0.106 and t-value of 0.135. Similar result is obtained for board composition which has regression coefficient of 0.017 with standard error of 0.094 and t-value 0.185. Furthermore, board size has regression coefficient of 0.021 with standard error of 0.049 and t-value of 0.438. Lastly, the regression coefficient of management compensation programs is 0.285 with standard error of 0.131 and t-value of 2.170.

Consequently, it is observed that all the four independent variables are significant with their respective significant values of 0.003 for governance structures, 0.004 for board composition, 0.002 for board size and 0.032 for management compensation programs. This is an indication that all the variables are significant and hence we accept the alternative hypotheses, that is: there is significant relationship between management compensation programs and organizational effectiveness for hypothesis one. There is significant relationship between management compensation programs and organizational effectiveness for hypothesis two. There is significant relationship between management compensation programs and organizational effectiveness for hypothesis three and there is significant relationship between management compensation programs and organizational effectiveness for hypothesis four.

The overall performance of the model is as indicated by the F-value of 5.778 with p-value  $< 0.05$ . This result indicates that the model is adequate and sufficient in relating the dependent and the independent variables.

The model for the research work is given as:

$$\text{OREF} = 10.369 + 0.014*GS + 0.017*BC + 0.021*BZ + 0.285*MCP \text{ Where,}$$

OREF represents organizational effectiveness

GS represents governance structures

BC represents board composition

BZ represents board size

MCP represents management compensation programs

From model (1), the result indicates that every unit increase in governance structure will lead to 1.4% increase in organizational effectiveness provided other independent variables are held constant. In addition, for every unit increase in board composition, there exists 1.7% increase in organizational effectiveness provided all other independent variables are held constant. In the same vein, for every unit increase in board size, there exists 2.1% increase in organizational effectiveness provided other three independent variables are held constant. Lastly, for every unit increase in management compensation program, there exists 28.5% increase in organizational effectiveness. This result shows that; management compensation program contributes more to the organizational effectiveness than other variables.

### **Summary and Conclusion**

The study objective was to explore the effect of corporate governance on the effectiveness of manufacturing firms. The study established that there is weak positive relationship between joint effect of board size, board composition, governance structure and management compensation programs on organizational effectiveness. Consequently, it is observed that all the four independent variables are significant to organizational effectiveness, accepting that board size, board composition, governance structure and management compensation programs have positive significant relationship with the effectiveness of the organization. This result indicates that the model is adequate and sufficient in relating the dependent and the independent variables. This result shows that management compensation program contributes more to the organizational effectiveness than other variables.

It can be concluded from the study that there is positive weak relationship between corporate governance and effectiveness of Sona Agro Allied Foods Ltd. It is also concluded that corporate governance components (board size, board composition, governance structure and

management compensation programs) contributes to the effectiveness of the organization, but it is concluded based on the result that management compensation program contributes more to the organizational effectiveness than other variables. The study concludes that sufficient evidence emerged showing that it is necessary to embark on good management compensation program which supports the organization in achieving better effectiveness.

The study recommends among others that Corporate governance requires more attention and commitment from corporate organizations in the formulation of custom, policies and laws so as to provide a guide and channel efforts towards the use of effective corporate governance in achieving organizational success. The organization should adopt effective management compensation programs which aid the employees in doing the right things that will help to improve effectiveness. Corporate organizations should also intensify efforts to ensure that the governance structure supports the effectiveness of the organization and that the Executive directors are placed in handling the affair of the organization since they have a deeper understanding of the organization operation. Organization should ensure that all board members should have relevant industry knowledge, qualifications, experience and skill required in stewarding the organization which will improve the effectiveness of the organization.

Finally, organizations should see corporate governance as a business opportunity that is profitable in the long run. This will give them a clear view of the ultimate goal of organizational success.

### References

- Abdulazeez, D. A., Ndibe, L. & Mercy, A. M. (2016). Corporate governance and financial performance of listed deposit money banks in Nigeria. *Journal of Accounting & Marketing* 5, 153-159.
- Adekunle, G. & Aghedo, R. (2014). Corporate governance and financial performance of selected quoted companies in Nigeria. *European Journal of Business and Management*, 6 (9), 23-28.
- Agyei-Mensah, B. K. (2016). Internal control information disclosure and corporate governance: Evidence from an emerging market. *Corporate Governance*, 16 (1), 15-23
- Ajagbe, W. & Ismail, O. (2014). Dividend smoothing and debt ratings, *Journal of Financial and Quantitative Analysis*, 41 (2), 439-453.

- Amer, M. (2014). The impact of corporate governance on firm performance: Evidence from the UAE, *European Journal of Business and Management* www.iiste.org ISSN 2222-1905 (Paper) ISSN 2222-2839 (Online) 6 (22), 67-71.
- Danquah, B. S., Gyimah, P., Afriyie, R. O. & Asiamah, A. (2018). Corporate governance and firm performance, *Journal of Accounting and Finance* 7 (3), 101-109.
- Bilal, Shahid, Muhammad, Hafiz & Arbab (2013). Impact of corporate governance on firm performance: Evidence from Sugar Mills of Pakistan. *European Journal of Business and Management*, 5 (1), 110-119.
- Cheema, K. U. & Din, M. S. (2013). Impact of corporate governance on performance of firms: A Case Study of Cement Industry in Pakistan. *Journal of Business and Management Sciences*, 1 (4), 44-46.
- Cross, T., Bazron, B., Dennis, K., & Isaacs, M. (1989). *Towards A Culturally Competent System of Care*. Washington, DC: Georgetown University Child Development Center, CASSP Technical Assistance Center.
- Dina, I. & Marina, D. (2014). Corporate governance practices and firm performance measured by Croatian Corporate Governance Index. *Economic Research-Ekonomiska Istraživanja* ISSN: 1331-677X (Print) 1848-9664 (Online) *Journal homepage: <https://www.tandfonline.com/loi/rero20>*
- Duc, A. & Thuy, C. (2013) corporate governance and firm performance: Empirical evidence from Vietnam Economic Regulation Authority, Perth, Australia; Open University, Ho Chi Minh City, Vietnam.
- Erhardt, W. & Shrader, V. (2013). *Board of Director diversity and Firm financial performance*. New York: Blackwell Publishing Ltd.
- Fekri A.S., Milad A.S., Hafezali I.H., Omar A. & Omer, B.T. (2016). Corporate Governance Characteristics and Valuation. *Journal of Economics, Finance and Administrative Science*, 21, 81-88
- Jamal & Waqas (2018). Impact of Corporate Governance & Capital Structure on Firm Financial Performance: Evidence from Listed Cement Sector of Pakistan. *Journal of Resources Development and Management Review*, 44, 1-15

- Juliet, Aduda, Gituro & Mwangi (2016). Corporate governance, firm characteristics, external environment and performance of financial institutions in Uganda: A review of literature. *Cogent Business & Management* 3: 1261526
- Khaliq & Muhammad (2013). Impact of Corporate Governance on Performance of Firms: A Case Study of Cement Industry in Pakistan. *Journal of Business and Management Sciences*, 1(4), 44-46.
- McGrath, S. K., & Whitty, S. J. (2015). Redefining Governance: From Confusion to Certainty and Clarity. *International Journal of Managing Projects in Business*, 8(4), 755-787.
- Santos, J. B. & Brito, L.A.L. (2012). *Toward a Subjective Measurement Model for Firm Performance*. BAR, Rio de Janeiro.
- Sicily, G. & Rotich, G. (2013). Influence of Corporate Governance on the Performance of Public Organizations in Kenya. *Journal of Finance and Accounting* 4(6), 23-29.
- Tanko M. & Kolawole, T. (2015). *Corporate Governance and Firm's Performance in Nigeria*. Department of Accounting, Kaduna, Nigeria.
- Wahyudin, A., & Solikhah, B. (2017). Corporate governance implementation rating in Indonesia and its effects on financial performance. *Corporate Governance. The International Journal of Business in Society*, 17(2), 250-265.
- Williams, C. & Anthony, J. (2013). The Impact of Corporate Governance on the Performance of Manufacturing Firms in Nigeria. *International Journal of Science and Research (IJSR)* ISSN (Online): 2319-7064



## NATURE AND PATTERN OF COMPUTER EDUCATION AMONG ORPHANS IN ORPHANAGE HOMES NIGERIA

<sup>1</sup>Muhammad Haruna Rasheed, <sup>2</sup>Zuwaira Haruna Rasheed & <sup>3</sup>Muhammad Isah

<sup>1</sup>Department of Computer Science,  
Waziri umaru federal polytechnic, birnin Kebbi

<sup>2&3</sup>Department of Arts and Social Sciences,  
Waziri Umaru Federal Polytechnic, Birnin Kebbi



### Abstract

*The study examined Nature and Pattern of Computer Education Among Orphans in orphanage homes Nigeria. Orphans are children's that are badly affected as a result of natural disaster and manmade disaster. United States Agency for International Development, argued that, orphan's children have reduced in other countries such as Asian, and Latin American. However, the number of orphans have grown up in Nigeria due to number of factors such factors are crime, HIV AIDS poverty and other related factors The study highlighted the emerging challenges in the lack of proper computer technology that could be able to improve the innovative pattern of Nigerian orphanage homes which raises number of concern demanding effective and efficient transformations from the government, non-governmental organizations, shareholders, spiritual organizations individual and many more. The article, consulted several valid second hand information by identifying, accessing and explaining ways in which government should improve and imposed computer technology in transforming the lives of orphans in orphanage homes in Nigeria The findings, therefore, revealed that, the impossible actions by the government due to inappropriate concentration on the level of skills and innovation which has manufactured lack of computer skills among them Conclusion and recommendations are drawn to guild possible actions plans for sustainable build in orphanage home.*

**Keywords:** Education, Orphans, Orphanage, and Nigeria

### Introduction

Orphans are children's that are badly affected as a result of natural disaster and manmade disaster. (United States Agency for International Development, 2008) argued that, orphans children have reduced in other countries such as Asian, and Latin American. However, the number of orphans have grown up in Sub-Sahara African (United National Children's Fund, 2006), noted that, in some African countries such as Utopian, has the largest number of orphans, according to UNCF, explained that, the rates of poverty, conflicts, and other natural

disaster will continue to rise the in the number of orphans in the area. (United Nations Children Fund, 2007) noted that, the high rate of Orphans have continue to affects children, families, communities and the nations at large. The position of the researchers argued that, orphans in an orphanage homes suffered series of educational problems particularly computer training so as to become effective and to meet the contemporary challenges in Nigeria

Atwine, 2005; Cluver et al. 2008, Killian and Durrhem, 2008; Makama et al 2002; Zhao et al 2007) argued that, when countries continued to lost their parents or loves once as a result of gear poverty, disease, or any other disaster both manmade and natural disaster, they furthered argued that, those children would be suffering from psychological problems such as lck of proper social welfare, stigmatization, lack of parental care, lack of community support and many more.

Increasingly, this paper would also demonstrate the provision of social welfare to orphans in Nigeria such social welfare includes provision of standard education through the application of digital methods of teaching, (Palicious & Sluschy, 2006)

International Social Security Association, 2005) noted that, in many countries in the world have developed the provision of both social and economic support, particularly social welfare needs. In Africa, social welfare programme was developed in 1950s and 1960s for white workers (Dixon, 1987) argued that, in those days' social welfare was established to benefits only employers. The study would demonstrate the vital application of digital methods of learning in Nigerian orphanage homes, however, number of governmental agencies like UNICEF, safe the Children WHO and many more have made rich donations in the parts of their services in promoting standard education in orphanages homes in Nigeria.

### **Statement of the Problems**

Nigeria is a rich country, inhabited by the poor and accounts for the highest percentage of orphans, with poor distributions of social welfare particularly in the area of modern teaching, to orphans. Orphanage homes in Nigeria have been neglected from poor distributions of social welfare due to perceived corruption that is digging in all of the orphanages in Nigeria. (Children on the Blink, 2004) argued that, Nigeria with the highest number of orphans worst 7. Million in 2003, The National Situation Assessment and Analysis on Orphans (2008), observed that, there is over 14 million orphans in the country, UNICEF Report 2007, noted that, out of 10.7 million of Nigerian children are orphans, which is associated with socio-cultural, political and economic factors. UNICEF 2007, further argued that, the care of orphans should be employ by the government and also their families or relatives so as to improve their wellbeing in the society. The burden of orphans in Nigeria has led to so many problems, rising in the behavior and societal disunity, the changing pattern of orphans behavior which

fundamentally risking the children life opportunities to go school, have good healthcare services, good growth and development, good nutrition and shelter. Similarly, if a child lost his parent either by accident, disease, conflict and any forms of natural or manmade phenomenon, a child begins to face a lot of problems such as fear, psychological problems, societal isolation and many more.

Similarly, the schools operate in the orphans homes where basically, ignored due to poor management and lack of qualified staffs to interact with those orphans. In the area of family values orphans children may engage in deviant behavior, association with peer groups which in one way or the other may endanger his or her life. In the area of interactions those orphans children may lose some vital means of interaction such as racism, prejudice, and others forms of discrimination. For example, Shetima, 2009; Aluaybea, 2009; Badamasiuy, 2009, argued that, only few consideration have been given to in relations to the conditions of orphans in Nigeria. UNICEF & UNAID, 2002, argued that, following the death of a parent either by sickness or any other courses, led children to become orphaned, which sometimes led the child into economic hardship, lack of love and care, withdrawal from school and increase number of abuse in the society.

The following are the research questions for the study:

- (i) What are the factors that led to the emergence of orphanage homes in Nigeria?
- (ii) How would you describe the nature and social welfare provision to orphans?
- (iii) What are those challenges which have been confronted in the provision of basic social welfare to orphans in Nigeria orphanage homes?
- (iv) What are the recommendations to overcome the orphans' challenges?

### **Conceptual Clarifications**

In 1948, WHO defined health as "a state of complete physical, mental and social well-being and not merely the absence of disease" Health could be considered in terms of a person's body structure and function and the presence or absence of disease or signs (health status), their symptoms and what they could and could not do ie the extent to which the condition affects the persons normal life (quality of life).

The position of the researchers, argued that health is one of the fundamental mechanism that enhances individual physical, mental and social wellbeing which without it could transformed into negative physical, mental and social wellbeing Education is necessary in orphanage homes; education is the process of facilitating learning, or the acquisition of knowledge, skills, values, beliefs and habits. And individual realizing its human potential and of becoming a subjective agent by actively exploring the material and social world, with the

hope to become a responsible and useful member in the society. However, we can measure education in terms of the quality of teachers, structure and the environment.

The researchers see Education as process through which a person's acquire knowledge, skills, attitudes, and morality so mass to become a responsible member in human society, additionally, the researchers, see computer as electronic devices that accept information, process information, store information and printout information's all of these are fundamental in transforming the educational standard of orphans in Nigeria.

An orphan is a child under age 18 years who has lost one or both parents irrespective of the cause of death. The report, Children on the Brink 2004 (UNAIDS, UNICEF and USAID, 2004) makes distinction among the following categories of orphans: Maternal orphans children under age 18 whose mothers have died; Paternal orphans -children under age 18 whose fathers have died; and Double orphans children under 18 whose mothers and fathers have died.

The position of the researchers, noted that orphans also are not necessary those that lost her parents rather those that engaged into unwanted pregnancy, and abandoned these children's and some parents who could not provide social welfare to their children they will decide to send their children to orphanage home, where they could enjoyed free education and free medical services.

## **Review of the Literature**

### **Brief Historical Development of Orphanage Homes**

An orphanage is a residential institution devoted to the care of orphan's children whose biological parents are deceased or otherwise unable or unwilling to take care of them. However, the used of institutionalized was fist established in the United State, later the formalization of orphanage home began to spread with formal administration format.

Plato, (Laws, 927) says "orphans should be placed under the care of public guidance " in European countries. Albania, there are approximately, 10 small orphanages in Albania each one has only 12-40 children residing. The nature of social welfare was effective. In Bulgaria, the Bulgaria government has shown fundamental interest in the proper coordinating and strengthening of orphanage homes. In 2010 the Bulgaria has adopted a national strategic plan for the period of 2010-2025 so as to improve the living standard of those orphanages.

The position of the researcher based on the argument on Plato, on orphans should be placed into public guidance, this accession could not be introduce in Nigeria due to poor patronage and weak governmental policy and programmes on orphans,. Orphans in Nigeria are facing

serious socio-economic and political problems which manufactured some of them into street bagging and other unwanted behavior

In Hungary, with flows of over 7000 orphanages homes, has adopted policy on national strategy for strengthening the fundamental rights of those children living in the orphanage homes from 2007 and will run until 2032. Romania, the Roman pattern of administration to orphanage was to provide social welfare through educating and engaging them into agriculture, mining, skill acquisition programmes and others, which will flows the reduction of orphanage in the area. The researcher understanding and explanations in relations to all these countries and their pattern of social welfare to orphans homes was very effective in the sense, policies and proper organization of the orphanages were conducted. In Sub-Saharan Africa, the majority of African orphanage especially in Sub-Saharan Africa appears to be funded by donors often from western nations rather than domestic government. In Ethiopia, for example,

### **Concepts of “Orphanage” in the 21st Century**

A critical conceptual question encountered in this study was how to define the term “orphanage.” Historically, “orphanage” has been defined as “an institution or asylum for the care of orphans” or as “a public institution for the care of orphans.” These definitions, reflecting the historical nature of orphanages, were found to offer little assistance in making distinctions among the facilities that currently comprise the broad variety of institutional settings for children and youth in the United States. Terms such as “asylum” and “orphan” have largely fallen into disfavor and, therefore, could yield little guidance in developing a working contemporary definition of “orphanage.”

It became necessary for purposes of this study to develop a definition of “orphanage” that captured the elements of care that historically have characterized “orphanages” but which also reflected the contemporary realities of institutional care for children. With these principles in mind and with the guidance of leading child welfare advocates, Children’s Rights adopted the following definition of “orphanage” for purposes of this study:

“An orphanage is a residential childcare facilities that is intended to care for children from the time of their admission until their maturity or emancipation, and which holds itself out as an acceptable or superior substitute for the children’s families. It does not function as a family resource center to reunify families or work to help children live in alternate families; nor does it provide comprehensive professional treatment services for children to address their emotional, behavioral, or other problems”

### **Overview of Orphan and Vulnerable Children in Nigeria**

The Nigeria Country Report (2004) defines an orphan as a child under the age of 18 years whose mother (maternal orphan), father (paternal orphan) or both (double orphan) are dead. A child is defined as a vulnerable when that child is most at risk of facing increased negative outcomes compared to the average child in the defined society. Negative outcomes include malnutrition, higher morbidity and mortality, low school attendance and completion rate and increased risk of abuse and psychosocial consequences. According to the National Plan of Action on Orphans and Vulnerable Children in Nigeria (2007), categories of children who could be vulnerable may not be exhaustive but for working purposes on a general note, a child is defined as a boy or girl below 18 years of age. An orphan on the other hand is a child (below the age of 18) who has lost one or both parents, irrespective of the cause of death. Those who have lost both parents are commonly referred to as “double orphaned”. The definition of vulnerability varies from society to society; therefore definitions are community specific. Nevertheless, the Federal Ministry of Social Development (2007) provides some key indicators determining children’s vulnerability including children that are:

From poverty stricken homes; with inadequate access to educational, health and other social support; live in a household with terminally ill parents or care-giver(s);

In line with the above, the National Action Plan of Nigeria enumerates specifically the list of children perceived as extremely vulnerable in communities to include:

Children with physical and material disabilities, Neglected children, Child beggars, destitute children and scavengers, Children from broken homes, Internally displaced children, Children who have dropped out of school, Abandoned children. (Orphans Voluntary Care, 2007).

The argument of the researchers stated that, with the above explanations on the positions of O.V.C, 2007, on the characteristics of children’s needed into orphanage homes are very vital. These argument have been captured in many literatures

**Fig. 1:** Some Evidenece Based of Orphanage Homes and their Computer Rooms in Nigeria



**Sources:** 2019, review work

This is one of the orphanage homes in Nigeria, Cross River State, this shows how fundamental and well organized this orphan's home, because adequate shelter is one of the fundamental ingredient in the provision of social welfare

**Fig. 2:** Another orphanage computer classroom, in Abuja, indicates that some orphanage schools engages orphans in the study of computer



**Fit. 3.**



Sources, 2019 review work

**Fig. 4**



**Sources:** 2019 reviewed work.

This shows that not all orphans have access to computer rooms, here are reviewed evidence from Maiduguri, orphanage home where student does have chairs

### **The Role of Social Workers and other agencies in the provision of standard education to Orphans in Nigeria**

Social work can be defined in relation to professional activities that involves in helping individuals, groups, or communities to enhance their capacity for social functioning and to improve the quality of life for every one by working toward the enhancement of the social and physical environments. Social workers believe in a society that takes care of its vulnerable members, in a world where children do not suffer from hunger, abuse, cold, illness and hardship. Social workers provide timely services to orphans and vulnerable children before dysfunction develops and include programs and activities such as parent education, nutrition education, family planning and premarital counseling.

Non-governmental organizations are groups of non-profits agencies that work to enhance the social welfare to weaker ones, particularly, in the orphanage homes, such social welfare includes provision of standard education, water, healthcare services and many more.

Today, social workers provide a wide range of services to orphans and vulnerable children. Some of the roles social workers perform include; the role of broker of human services, the role of a teacher, counselor, an advocate, a case manager, facilitator, enabler and the role of an activist. Social worker as a broker links the orphans and vulnerable children to appropriate human services and other resources. The social worker is always placed in a position of being the professional person most likely to facilitate linkage between the orphans and vulnerable children and community resources. According to Sheafor (1994:17) as a human services broker, the social worker must be knowledgeable about the various services and programs available, maintain an up to date assessment of each one's strengths and limitations.



Social worker use to be teachers teaching in various orphanage homes to enable them to be productive, as a teacher prepares the OVC with knowledge and skills necessary to prevent problems or enhance social functioning. The purpose of social work practice here is to help OVC change dysfunctional behaviour and learn effective patterns of social interaction. An effective service plan to orphans and vulnerable children is a part of social work practice because it is an agreement to guide the shared efforts of household members and the resources that are present to support them in achieving change around specific behaviours that contribute to conditions that make their children vulnerable (AIHA; 2008)

Social worker as a counselor or clinician helps the OVC to improve their social functioning by helping them better understand their attitudes and feelings, modify behaviours and learn to cope with problematic situations. The OVC's situations must be thoroughly understood and their motivation, capacities and opportunities for change assessed. Social worker as an advocate becomes the speaker for the OVC by presenting and arguing their cause. Advocacy is becoming an increasingly popular role of social workers. Social worker as an advocate plays an important role of reconciliation, liberation, and recovering of deprived properties and rights of people especially the disadvantaged groups such as the orphans and vulnerable children (Coulshed, 1998). Butrym (1976) claims that social work in common with other helping professions aims at promoting human welfare through the prevention and relief of suffering. Social workers participate in planning programs, identifying the needs of certain high risk groups such as OVC, and organize services for such problems as child abuse, rape and high risk infants. According to Brieland, Costin and Atherton (1980:272), social workers can play a preventive as well as therapeutic roles. Through an understanding of implications of various high-risk situations, the social work can aid the orphans and vulnerable children and their families to anticipate problems and cope more effectively.

The social worker's role is to emphasize the functioning capacities of the orphans, help reduce pressures, promote rehabilitation and prevent unnecessary dysfunction. Where there are social and emotional factors which complicate the OVC's physical adjustment, the social worker is part of the team which evaluates the OVC's ability to maintain themselves. Where recovery is impeded because of economic deprivation, inadequate housing, family tension or lack of understanding, the social worker will be called upon. Statistics revealed that there is a high level of deprivation and exclusion from basic health among the OVC in Nigeria and today, social workers play many roles in the provision of health care in a variety of settings to orphans and vulnerable children.

In-fact, social work in health care, particularly in working with the orphans and vulnerable children is one of the fastest growing occupational areas today. Social workers provide direct services to the families of orphans and vulnerable children living in poverty, advocate for

programs and policies that improve the lives of the poor and reduce poverty at the community, state and federal levels, and develop and administer policies and programs that serve Nigeria's poor. In the opinion of Ambrosino et al (2005:288), the essential and important roles for social workers in health care settings include understanding how individuals' cultures shape their views about health and wellness, illness, health care providers and interventions, birth and death, their own roles in preventing and dealing with health-related concerns and helping to empower persons to communicate those views to others involved in their care. Social workers in health care settings provide a number of other functions to the orphans and vulnerable children (OVC).

### **Gaps in Literature that this Study Tends to Fill**

Many studies have been conducted on orphanages, vulnerable children: their rights, privileges, development and future. Others examine the causes, conditions, and prospects of orphans and vulnerable children in Nigeria (example Shetima, 2009; Aluaigba, 2009; Badamasiuy, 2009; Unicef, 2006, FMWA, 2004 and others, they gave comprehensive explanation on social welfare of orphanage without understanding the fundamental values associated to Nigeria society. However, The Rapid Assessment Analysis Action Planning (RAAAP), 2004, etc.), Nevertheless, little attention has been paid in Nigeria to the dynamic relationships that led to the conditions of the lack of computer teaching methods in some orphanage homes in Nigeria, today the world is changing rapidly into digital era and orphanage homes are lacking computer teaching. Virtually, specifically and more importantly, collective societal response as intervention strategy for solidifying and cementing relationship, number of governmental organizations, no-governmental

Organizations, spiritual organizations, stakeholders and individual have contributed positively in the development of education in orphanage homes. Yet orphanage homes suffered series of modern methods of teaching. And the fundamental problems associated with all of these are corruptions that hinder many orphanage homes in Nigeria. Has been neglected or silenced. This study seeks to fill the existing gaps as identified above. Although the plight of the OVC is acknowledge throughout Nigeria, it has not received adequate attention from researchers, social workers and human rights workers.

### **Theoretical framework: Frameworks for Responding to the Issues of Orphans**

**Human Security Analysis** is adopted. Mahbulul Haq first drew global attention to the concept of human security. Human security perspective is a combination of threats associated with war, genocide, and the displacement of populations (Human Security Research Group, 2010). At a minimum, human security means freedom from violence and from the fear of violence. It is people centered, focusing on the safety and protection of individuals, communities, and their global environment (Human Security Policy Briefing, 2011).

United Nations Development Programmes (UNDP) report conceptualized human security as providing safety for the people from hunger, diseases, oppression and other chronic threats as well as protecting them from sudden and hurtful disruptions in the patterns of daily life (Shiro, 2007). The emergence of the human security approach as an area of developmental and intellectual discussion was the product of a convergence of various complex factors. This therefore challenged the traditional dominance of state-centric paradigm of security. Human security is an emerging paradigm for understanding global vulnerabilities whose proponents challenge the traditional notion of national security by arguing that the proper referent for security should be the individual rather than the state.

There are two major schools of thought 'that attempted to explicate the best practice that could guarantee human security. They are: "Freedom from Fear Approach" and "Freedom from Want Approach." These approaches clearly center on what threats individuals should be protected from and over the appropriate mechanisms for responding to these threats. Freedom from fear' seeks to limit the practice of Human Security to protecting individuals from violent conflicts while recognizing that these violent threats are strongly associated with poverty, lack of state capacity and other forms of inequities. This approach however argues that limiting the focus to violence is a realistic and manageable approach towards human security. According to this approach, emergency assistance, conflict prevention and resolution, peace-building are prerequisite to human security. Freedom from want 'on its own point of argument advocates a holistic approach in achieving human security and argues that the threat agenda should be broadened to include hunger, disease and natural disasters because they are inseparable concepts in addressing the root of human insecurity (UNDP, 1994) and they kill far more people than war, genocide and terrorism combined (Tadjbakhsh, 2007).

"Freedom from Fear", it expands the focus beyond violence with emphasis on development and security goals. Though these approaches to human security may appear to be opposites, they are complementary to each other rather than contradictory. After all, each of them emphasizes the security of individuals in society. In fact, the analytical strength of this approach is based on its ability to situate the people at the heart of security. This therefore means that the welfare of the people should be paramount. In other words, the physical security of people as well as the socio-economic wellbeing of the people should be prioritized by the state. That is why human security approaches ask, Stabilization for whom and for what purpose? The Responsibility to Protect (doctrine details each state's responsibility to protect its population from genocide, war crimes, crimes against humanity and ethnic cleansing, mass atrocities (Human Security Policy Briefing, 2011).

Accordingly, if the State is unable to protect its population, the international community has a responsibility to help build state capacity for early-warning, mediating conflicts, security sector reform, and many other actions. In the face of violent attacks against the people, and the state does not have the capacity to handle the situation alone, and refuses to seek foreign assistance due to perhaps national pride and myth of indivisibility of sovereignty, the human rights of the people would continue to be violated. In this situation, human security, social cohesion, and national integration may be elusive.

Increasingly, the position of the researchers, noted that education is one of the bedrock of development in any society, therefore, modern educational through the application of computer will be important in all orphanage homes in Nigeria. However, the linkages between freedom from fear and free from want, what the orphans want most is the applications of computer teaching in other to meet the demands of the current challenges and at the same time to improved there socio-economic and political status.

### **Conclusion**

Computer application and teaching in orphanage homes is one of the vital tools that will improve the economic benefits of orphans and to become self-reliance. However, orphanage homes suffered series of traditional methods of teaching some could not have even classrooms, where they could acquire knowledge and other skills. Similarly, computer is very significant in the promotion of knowledge among orphans. There is need for government and other bodies to contribute in establishment of computer teaching in Nigeria orphanage homes.

### **Recommendations**

1. Government should improve computer studies and make it practical to students in orphanage homes, so as to enhance their skills.
2. Stakeholders, should assist in the transformation of modern educational methods of teaching that is computer applications in other to meet the current demands
3. Non-governmental organization and charity organizations should help in recruiting teachers that are capable in teaching computer studies both theory and practical. In other to assist orphans.
4. Social workers, shall also play a very rich role in engaging into those camps, making sacrifices teaching, caring, advice and other important life improvement

## References

- Abraham, M. (1954). *Motivation and personality*, New York: Harper.
- African *Charter on Rights and Welfare of Children (ACRWC)*. Retrieved October 19, (2018) from: <http://www.africa-union.org/child/home.htm>.
- Ainsworth, M. & Filmer, D. (2002). Poverty, AIDS and children's schooling: A targeting dilemma". Working, Papers - Education, Child Labour, Returns to Schooling. No. 2885, Washington, D.C.: World Bank.
- Amutabi, M. N. (2006). *The NGO factor in Africa: The case of arrested development in Kenya*. New York: Routledge.
- Anyanwu, C. N. (1992). *Community Development: The Nigerian perspective*, Ibadan: Gabeseher Education Publishers.
- At a Glance: Nigeria (2004). *United for Children, UNICEF*. Retrieved October 05, 2018 from <http://www.unicef.org/infobycountry/nigeria.1463.html>.
- Badamasiu, J. (2009). *Obligations and rights of the parents under the Child's rights Act: A Shavian perspective*. Kaduna: AJY Press & Co.
- Baylies, C. (2002). The impact of AIDS on rural households in Africa: A shock like any Other?" *Development and Change*, 33(4): 611 - 632.
- Beelen, N. (2007). *Exchange on HIV/AIDS, sexuality and gender*. (Newspaper Online). (cited 2011 February,15)
- Birmingham, D. (1995). *The Decolonization of Africa*, University Press.
- Bradley, M.T. (2003). *Nigeria since independence and the impact of Non- governmental organizations on democratization*, New York: Edwin Mellen Press Ltd.
- Brieland, C. & Atherton, H. (1980). *Contemporary social work: An introduction to social work and social welfare*; 2nd edition, USA.
- Butrym, Z. (1976). *Social work in medical care*: Routledge and Kegan paul Ltd, London.
- Coulshed, V and Orme, J (1998). *Social work practice; An introduction*, London, Macmillan press Ltd.

Children's Rights (1995). *United Nations Department of Public Information*, Retrieved October 19, 2010 from: <http://www.un.org/rights/dpi1765e.htm>.

Coles, C. M. (1996). *Three generations of Hausa women in Kaduna, Nigeria*, In K.Sheldon (ed.). *Courtyard, Markets, City Streets: Urban Women in Africa* (pp. 73 - 104). Colorado: Westview Press.

Derefaka, A. A. (2004). *Cultural Identity and Globalization: The Nigerian Experience*. In O. Duro, S. Gupta, T. Omoniyi, E. Adegbija, and S. Awonisi (eds.).

Evans, M. & Murray, R. (eds.) (2008). *The African charter on human and people's rights: The system in practice, 1986 - 2006*. Cambridge: University Press.

Federal Ministry of Women Affairs and Social development (FMWA, 2006). *National plan of Action 2006-2010 on orphans and vulnerable children, Child Development, Department, Abuja: Nigeria*.

Federal Ministry of Women Affairs and Social Development (2008). *The Key findings of 2008 situation assessment and analysis on orphans and vulnerable children (OVC) in Nigeria*. Abuja, Nigeria 2008.

Federal Ministry of Women Affairs and Social Development Nigeria (2006). *OVC National Plan of Action 2006-2010 Abuja, Nigeria*.

Federal Ministry of Women Affairs and Social Development (2007). *National plan of action on orphans and vulnerable children in Nigeria*, Abuja: Nigeria

Federal Ministry of Women Affairs/UNICEF (2004). *A rapid assessment, analysis and action planning process (RAAAP) for Orphans and Vulnerable Children: Nigeria Country Report*, August.

Federal Republic of Nigeria (2007). *Official Gazette: Legal Notice on publication of the details of the Breakdown of the national and state provisional totals, 2006 census*. Lagos, Nigeria.

Garba, A.G. (2007). *Ruling ideas and social development in Sub-Saharan Africa: An Assessment of Nationalist, Keynesian and Neoliberal Paradigms*. In J.O. Adesina (ed.). *Social Policy in Sub-Saharan African Context: In Search of Inclusive Development* (pp. 54 - 86). New York: Palgrave Macmillan Press.

Huber, U. & Gould, B. (2002). *Primary school attendance in Tanzania: How far is it affected by orphanhood*, Paper presented at the Annual Conference of British Society for Population Studies, University of Newcastle, September 9 – 11.

Jasen, M. (2000). *Children and the right to grow up in an environment supporting their Health and Well-Being*, A Sound Environment Provided for and Encapsulated in the Convention on the Rights of the Child.

Ladan, M. T. (2006). *Situation analysis and assessment of orphans and vulnerable children (OVC)*. Nigeria: Concept Paper.

Lanchman, P. et al (2002). *Challenges facing child protection: Overview lessons" in child abuse and neglect*, 26: 587 – 617.

Mcleod, J. & Shanahan, M. (1993). Poverty, parenting and children's mental health, *American Sociological Review*, 58, 3:351-66.

Mcp hail, T. (2009). *Development communication: Refraining the role of the media*, Chichester, West Sussex: John Wiley and Sons Limited.

Mivanyi, Y. J. (2006). Nigeria. In J. Gorsas, J.W. Berry, F.J.R. Van de Vijver, C. Kagitcibasi, & Poortinga, Y.H. (eds.). *Families Across Cultures: A 30- Nation Psychological Study* (pp. 419 – 426). New York: Cambridge University Press.

Norman, G. (2002). *Resiliency and vulnerability to adverse developmental outcomes associated with poverty*. In T. Thompson and Hupp (eds.). *Saving Children at Risk* (pp. 45 – 60). California: Sage Publications.

Pfleiderer R & Kantai O (2010). *Orphans and vulnerable children programming in global funds HIV/AIDS grants in Kenya*, Washington DC: Future group, Health policy Initiative, Task Order

Sanda, A.O. (1987). Nigeria: The welfare system. In J. Doxon (ed.). *Social welfare in Africa* (pp. 164 – 183). New York: Croom Helm Ltd.

*The Report of the National Guidelines and Standards of Practice on Orphans and Vulnerable Children* (2007). A Publication of the Federal Ministry of Women Affairs and Social Development, Abuja: The Child Development Unit.

UNAIDS and UNICEF (2006). *Africa's orphaned and vulnerable generations affected by AIDS*. 2006. pp. 1-52. [http://www.unicef.org/publications/files/Africas\\_Orphaned\\_Olagbuji\\_and\\_Okojie](http://www.unicef.org/publications/files/Africas_Orphaned_Olagbuji_and_Okojie)

UNICEF-Nigeria (2007). *The status and situation analysis of the implementation of the rights of the children in Nigeria*. Lagos: UNICEF.

*United Nations Action on AIDS – UNAIDS. United Nations' Children's Fund – UNICEF, and United States Agency for International Development – USAID (2004). Children, the Brink 2004: A Joint Report of New Orphan Estimates and a Framework for Action*. New York: UNICEF and USAID

United Nations Children's Fund (UNICEF) & Project (2004). *A rapid assessment, analysis and action planning process (RAAAP) for orphans and vulnerable Children: Nigeria Country Report*. New York, USA. 2004.

*United Nations Children's Fund, Joint United Nations Programme on HIV/ AIDS and United States Agency for International Development (2004). Children on the Brink 2004. A joint report of new orphan estimates and a framework for action*. 4thed. New York, USA.

United Nations' Children's Fund – UNICEF (2004). *The framework for the protection, Care and support of orphans and vulnerable Children Living in a World with HIV/ AIDS*. Retrieved October 19, 2010 from: <http://www.Unicef.org/aids>.

United Nations' Children's Fund – UNICEF (2005). *The state of the world's children*, . New York: UNICEF.



## IMPACT OF INFORMATION TECHNOLOGY IN SOME SELECTED SECONDARY SCHOOLS IN KEBBI STATE

**Muhammad Haruna Rasheed**

*Department of Computer Science,  
Waziri Umaru Federal Polytechnic, Birnin Kebbi*



### **Abstract**

*This paper examines the impact of Information technology in public secondary schools in Kebbi State and how information's technology have affected every aspect of human activity and have a potential role to play in the field of education and training, specially, in distance education to transform it into an innovative form of experience. The need of new technologies in teaching learning process grows stronger and faster. The information age becomes an era of knowledge providing sound and unmatched feasibility for discovery, exchange of information, communication and exploration to strengthen the teaching learning process. Information technologies help in promoting opportunities of knowledge sharing throughout the world. These can help the teachers and students having up-to-date information and knowledge. Accurate and right information is necessary for effective teaching and learning; this paper was purely conceptual in nature and the researcher had employed secondary methods of data collections through the application of test books, journals, magazines, interment and other secondary valid information. The researcher had fundamentally stated it findings and recommendations.*

**Keyword:** *Role, Information, Primary, Secondary, Technology*

### **Introduction**

Education is one of the fundamental tools that could enhance socio-economic and political development of the entire world. It has been observed that number of countries across the globe have experiences one forms or the other in the development of their country, example, in the developed nations like (USA) United State of America, has put more emphases in the area of education and through the application of computer teaching.

One of the basic functions of education is preparation of students for life. This function in 21st century may be participation in an information rich society, where knowledge is regarded as the main source for socio-cultural and politico-economic development of countries and/or nations. Information rich societies are developed and dominating and they are controlling the information throughout the world. Information encompasses and relies on the use of different

channels of communication, presently called information and communication technologies (Hussain, 2005) and would be incorporating better pedagogical methods to cope with such emerging situations.

These have changed the scenario of education particularly, in Kebbi State and instruction making teaching learning process more productive creating collaborative, learner centered and interactive global learning environments. Therefore, information technologies are assumed to play a constructive role in education to make the teaching and learning process more productive through collaboration in an information rich society. (Hussain, 2005)

Information rich society promotes new practices and paradigms for education where the teacher has to play new role of mentoring, coaching and helping students in their studies rather to play the conventional role of spoon feeding in the classrooms. Students can learn independently having a wide choice of programme selection and access to information. Students can be involved in skill oriented activities in group learning environments for accumulated knowledge. They can interact and share learning experiences with their teachers and fellow learners in knowledge construction and dissemination process. They can receive and use information of all kinds in more constructive and productive profession rather depending upon the teacher. (Hussain, 2005)

Branson (1991) stated that, students learn not only by the teachers but they also learn along with the teachers and by interacting with one another. Indeed, now students can learn much more than that the teacher teaches in conventional learning environments. For example, in Nagari College Birnin Kebbi students engaged in computer operating due to changes in the information technology. In the productive teaching learning process teachers and students have to use information technologies according to their requirements and availability.

### **Statement of the Problems**

Problems of information technology particularly, in the developing nations have hindered series of socio-economic and political development. However, Nigeria has been classified as one of the richest nations in Africa with low practical aspect in information technology. Many secondary and primary schools in Nigeria suffered number of practical aspect in teaching information technology; similarly, number of factors could be associated with low or no information technology in many public secondary schools in Nigeria, particularly, in some selected secondary schools in Kebbi state. (Julie, 2013). Those factors are lack of genuine software, which is one of the fundamental problems facing many secondary schools in Kebbi state. Their library where not equipped with modern technology and absent of software, insufficient computers in the class rooms and library, poor speed of interments, lack of motivation from both teachers and students, lack of qualified teachers and experts staffs for

training, poor administrative support, poor curriculum, lack of good maintenance. However, all of the were the engines that supported problems facing effective distribution of information technology in three selected secondary schools in Kebbi state.

Virtually, numbers of organizations, such as governmental organizations, non-governmental organizations, spiritual organizations, and shareholders, individual have contributed in the supply and encouragement of information technology in those schools. It has been suggested those organizations could not be enough yet additional agencies need to interfere in the affairs of information technology in all secondary schools in Kebbi state.

### **Objectives of the study**

1. To examine the factors that hinders low teaching of information technology in Kebbi state
2. To highlight the supports of other agencies in supporting information technology in secondary schools
3. To look at suggestion on how to improve information technology in secondary schools

### **Literature Review**

#### **The Concepts of Information Technologies**

The history of information storage and dissemination indicates that human being used different things for information storage, its display and transmission. In different ages people used different materials and methods for communication such as rocks and stones, papyrus, palm leaves, animal leather and handcrafted manuscripts for storing and transmitting the information from one place to another and to the next generation. These means of information were limited and confined to the elites but “the advent of printing enabled information to be truly widespread throughout the world to move to a more equitable level in terms of access to knowledge” (Menon, B., 2000).

Similarly, the positions of the researcher, noted the fundamental background of information technology from primitive to more modern methods, however, yet number of countries could not improved in the area of information technology, example of my country Nigeria were many secondary schools depend primary on local methods of teaching despite long history of traditional methods

At present, knowledge may be regarded as power and it comes from having information. Information encompasses and relies upon the use of different communication channels or technologies -called information technologies, for its effectiveness and equal access. Information technologies may extend knowledge beyond the geographical boundaries of a state or country providing relevant information to the relevant people round the clock. (Menon, B., 2000).

Information Technology “is any computer-based tool that people use to work with information and support the information and information processing needs of an organization” (Haag, 1998). It includes computers and its related technologies; WWW, Internet and Videoconferencing etc. Information technology can be used to promote the opportunities of knowledge dissemination. It can help the teachers and students having up-to-date information and knowledge.

Accurate and right information is necessary for effective teaching and learning; and information technology (Haag, 1998) is a “set of tools that can help provide the right people with the right information at the right time.” In this sense, information technologies may be the result of knowledge explosion, where according to Marriam, and Cafarella, (1997,) “computer technology (software) extends the mental ability.” Therefore, information technologies may include computer and its related technologies of high tech and low touch nature. Charp, (1994) called them emerging technologies and stated that these are the products coming out of laboratory and into the hands of educational community. These include wireless communications, the information highway, asynchronous mode, integrated services digital networks (ISDN), multimedia applications, personal digital assistants, artificial intelligence and virtual reality. These technologies would be big of brain and small of mass, depending upon computer technology for their effectiveness and increased capabilities. Similarly, Rashid, M. (2001) discussed the interactive video, CD-ROM, compact video disc, Internet, WWW, teleconferencing, computers, satellites and e-mail as emerging information technologies, and according to him these are “current technologies incorporating into the teaching learning environment process”

However, the argument of the researcher is how ICT Revolution in the 21<sup>st</sup> century be effective and efficient in public secondary schools in Kebbi. It was understood that, despite digital ear 97% of public secondary schools engages in analog methods of teaching.

### **Information Technologies and Methodological Process of Teaching in Kebbi State**

Information technology is one of the vital and contemporary tool in improving student intellectuality and allow him to be more independent, in the process of innovation and creativity. And it Making Students Independent in their Studies, Using information technologies students can decide about their studies, learning time, place and resources in a better way. Number of studies has been conducted in some selected secondary schools which are Abdullahi Fodiyo Secondary School, Government Girls Secondary School, and others. Students can work in more supportive environments, seek help from teachers and fellows, and share their learning experiences and ideas in romantic and productive fashion. Dede (1996, p.4) stated that the development of high performance computing and communication is creating new media such as the Www and virtual realities. In turn these new media enable

new type of messages and experiences, such as interpersonal interactions in immersive synthetic environments lead to the formation of virtual communities. The innovative kinds of pedagogy empowered by these emerging media and experiences promoted the opportunities of distance education and at present virtual education and eliminated the barriers of distance and time. New and innovative learning experiences would be enhanced and encouraged by these technologies, as by virtual communities, which exist by interactions across the globe through global network of computers round the clock.

The writer view on information technology is over emphasis due to the fact that, number of countries have developed only because they put more emphases on information technology. Nigerian student could not have adequate and effective information technology such as library, free access to information online, access to computers, access to other information that could improve the quality of education. Yet number of student in public secondary schools in Kebbi could not have email. Even in the tertiary institutions.

The global sharing of experiences would make possible the group presentation form of instruction in distance education. Distance education encompasses and relies on the use of information technologies to make learning more productive and more individualized, to give instruction a more scientific base and make it appropriate & more effective, learning more immediate and access to resources more equal. These remarkable aspects can expand the quality and quantity of instructional resources. They can serve learners at their ease in terms of time and place. Rashid (2001) stated that:  $\frac{3}{4}$  Both teachers and learners can work with others at remote sites.  $\frac{3}{4}$  The community of learners can expand to include virtually anyone who wishes to obtain information and who is not excluded by policy or cost.  $\frac{3}{4}$  They can provide real access to experts in universities, research laboratories, the business community, government agencies and political offices.

### **Impact of Information Technologies in Secondary Schools.**

Information technology can transform teaching and learning by offering alternatives to the teacher provided information, access to virtually unlimited resources and opportunities for real world communication, collaboration and competition. The phases of this process as described by Marriam et al (1997) developing awareness recognizing that something is wrong or different;  $\frac{3}{4}$  exploring alternative—researching for new ideas from other institutions and acknowledging that change is needed;  $\frac{3}{4}$  making a transition—leaving the old approaches behind (or dramatically changed);  $\frac{3}{4}$  achieving integration—putting the pieces from the transition phase back together; and  $\frac{3}{4}$  taking action—putting new ideas into operation”.

The process can work at instructional programme or institutional level and one or more phases work simultaneously. Traditional lectures and demonstrations can become web- based

multimedia learning experiences for distance learners. Web can enrich the learning resources and institutions refocus from teaching to learning, from teacher to learner. It can create learning environment throughout the world by networked learning communities. Networks may create educative environments embedded in democratic philosophy of instruction and helping learners learn. The characteristics of which are:  $\frac{3}{4}$  "respect for personality;  $\frac{3}{4}$  participation in decision-making;  $\frac{3}{4}$  freedom of expression and availability of information; and  $\frac{3}{4}$  mutuality of responsibility in defining goals, planning and conducting activities and evaluating [the process]" (Knowles 1980).

The writer suggestion on the philosophical ideas of information technology not only in the area of impacting knowledge and skills but also in improve the quality of country manpower effectively and efficiency. It promotes the socio-economic and political status of individual and society in general. It also lead fasted growing economic. Similarly, technology will reduce the gabs of poverty and unemployment in the country and make learning more effective, efficient and faster.

Learning may take place more effectively and dynamically in educative environments where teacher and learners are open to each other to interact and exchange information and experiences in a friendly way. Ennis (1989) concluded in a study "Openness on the part of instructor increased their [learner's] desire to discuss problems or topics of interest... these discussions expanded their [learner's] understanding of the content and assisted them in planning the information within a relevant context in their own lives". Educative environments can enhance and shape the teaching learning process to achieve the desired goals. There is a natural tendency for students to learn and learning can accelerate, in interactive and encouraging environments. Accelerating the encouraging environments may be psychological climates and students' interactions can create them. Interactions of students can make learning environment more effective and meaningful and 'much of learning takes place in a meaningful environment'. Learners may get immediate feedback and reinforcement through web-based learning.

Internet and WWW provide learners latest relevant information at their own pace and they can form a virtual community of learners at global level. Teaching organizations are adopting information and communication technologies specially the computers, World Wide Web, teleconferencing and educational television because of their cost effectiveness, access and flexibilities of choices.

### **Students Use Information Technologies for the Purpose of the Following**

Number of factors associated with purpose of using information's technology in schools

1. Participate in a media revolution, profoundly affecting the way they think about and use information technologies. This greatly improve the standard of students in innovation and creativity
2. Improve the ways of learning in new learning fashions
3. Extend the ability and skills of applying their learning in real situation. It makes learning faster and easy, students now use technology easy access to website
4. Working in groups for cooperative and collaborative learning
5. Developing self-learning habits at their own pace and time. The issue of eleraning such as National Open University of Nigeria, education, agricultural technology etc

Information technologies facilitate students in their learning process through their active participation on one hand and help teachers on the other hand.

A shift from competitive to a cooperative goal structure Collaborative and cooperative learning approach provides learners the opportunities of extensive interaction. Students have access to extensive databases and share their own work through networked communications to work on collaborative projects. Teachers guide the students on how to share and interact in networked collaborative learning environments.

A shift from the primacy of verbal thinking to the integration of visual and verbal thinking. Using information technologies students would have extensive experience with video than with print, yet instruction is based primarily on print. However, visual literacy is poorly understood and poorly utilized in perceiving instruction. Teachers need to consider what capacities for visual knowledge and skills students should possess, and determine how they can ensure progress towards developing these capacities.

Information technology can help the teacher on the one hand and facilitates the learners on the other hand. Both, teachers and students get rid of their routine work, and have to play their new roles in new situations respectively. Teachers spend much of their time in assisting the students rather lecturing; and students access the information of their need.

Another important tools in information technology it engages lecturers into research and development, it improve the level of understanding and improve the quality of learning and good teaching environment

### **Futures of E-Educational Technology**

According to Sharma & Sharma (2006), characteristics of the educational technology are described as below

1. Educational technology applies scientific principles to the problems of education.

2. Educational technology puts emphasis on the development of the methods, procedures and techniques for the successful, useful and effective teaching learning process.
3. Educational technology lays stress on the designing and measuring instruments and tools forth reassessment and evaluation of teaching learning outcomes.
4. Educational technology makes the teaching learning process more facilitated and effective by media, methods, and techniques and by controlling classroom environment.
5. Educational technology is involved in three aspects in education e.g. input, teaching learning process and output.
6. Educational technology includes the applications of electronic media in education as well as systems approach.
7. Educational technology play crucial role as medium of communication.
8. Educational technology is a broad and comprehensive term. It includes different terms e.g., teaching technology, instructional technology, micro teaching, programmed learning and system analysis etc.
9. Educational technology is not the synonyms of the audio visual aids in education but it is broader and comprehensive.

The researcher argued that, e-education in the 21<sup>st</sup> century is one of the leading system of learning in the entire world. Today number of country engages in e-education through the application of technology. For example, student would be in Nigeria having lectures, downloading materials from the internet, etc. all of these are done easily and faster, this is trying to demonstrate the power of information technology

#### **(I.C.T). in 21st Century**

Adebajo, 2016. Argued that, additionally, the concepts of electronic and technology have greatly impacted education around the world, but specifically, Nigeria we have incorporated ICT in educational curriculum for secondary schools, in 2004 edition on national policy on education. The use of ICT in educational industry has promote easy learning and research in Nigerian institutions, and re-manufactures online courses, which have proven to be very effective because it provides a low cost alternative to higher education. Adebajo, noted that, ICT, IN 21ST century has provided easy access to research and development, online materials.



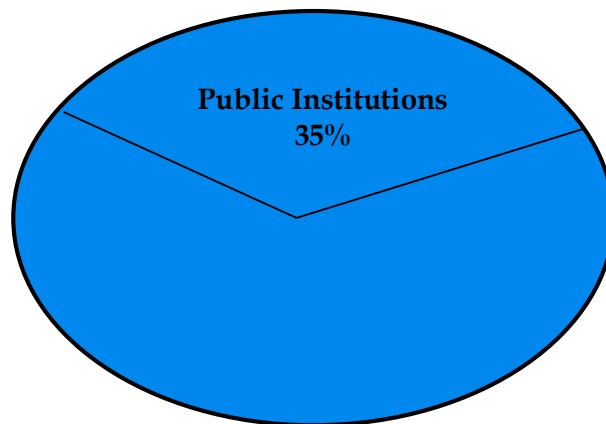

The application of information and technology in secondary schools in Birnin Kebbi is very low due to the fact that number of factors were associated. The above indicates that, only 35% of schools engage in the study of (ICT)

### **Conclusion**

Information technology is one of the fundamental instrument that bring about development in every country across the world, it has improve the standard of many countries in the globe, particularly, the developed nations such as U.S.A. England, etc. information technology is growing in Africa, particularly, Nigeria which because of some factors that it could not fully achieved the application of information technology in schools particularly, in Kebbi state.

### **Recommendations**

1. Government and the private sector should pull in more effort and resources towards the development of education
2. Educating and re-orientation of teachers, parents and students on the need to discourage examination malpractice in schools
3. More vocational and technical education centers be establish and the few existing ones properly equipped and staffed.
4. An independent inspectorate committee should be put in place to regularly monitor activities in schools as the existing inspectorate unit has seize to function effectively v Government should take over payment of enrolment fees for both primary six examination and secondary schools external examinations.
5. Qualitative and affordable education should be made available for all Schools should be properly staffed and equipped.

## References

- Dehkhoda, A. (1997). *Dehkhoda dictionary and encyclopedia*, Tehran University Press, Tehran.
- Ansari, H. (2004). Pluralism in Iranian modern architecture, *The Journal of Architecture and Civil Science*, 20: 10- 14.
- Asadi, M. (2004). *A question on technology*, Andis cultural institute, Tehran.
- Ahmadinezhad, M. (2003). *Fundamental concepts in architecture 3rd version*, Khak Publications, Tehran.
- Pakzad, J. (2003). *Fundamental principles and the process of civil designing*, Tehran university, Tehran.
- Noghrehkar, A. (2008). *Introduction to Islamic identity in architecture and urban planning*, Payam-Sima Publication and Design Company, Tehran, Iran, pp: 536-539. 7.
- Mirmiran, S. (1997). A New trend modern Iranian architecture, *The Journal of Architecture and Civil Science*, 50: 1-14.
- Memarian, G. (2004). *An exploration of the theoretical principles of architecture*, Sourush Danesh Publications, Tehran.
- Golmahamadi, A. (2000). *The globalization of culture and identity*, Tehran University, Tehran.
- Mazini, M. (1994). *Space, time and architecture fourth edition*, Science and Culture Publication, Tehran.
- Pakzad, J. (2004). *Papers on civil spaces in historical Iranian Context*, Shahidi Publication, Tehran, Iran, pp: 51- 61.
- Motallebi, G. (2005). *A humanistic orientation to the organization of civil spaces fine arts*, Publications, Tehran.
- Soltanzadeh, H. (2005). *Civil spaces in Iranian historical contexts*, Cultural Research Office Bulletin, Tehran.

## TECHNOLOGICAL INNOVATION AND ORGANIZATIONAL PERFORMANCE

**<sup>1</sup>Mukail Aremu Akind & <sup>2</sup>Yusuf Adebola Bako**

*<sup>1</sup>Department of Taxation,*

*Federal Polytechnic, Ilaro, Ogun State, Nigeria*

*<sup>2</sup>Department of Business Administration and Management,*

*Federal Polytechnic, Ilaro, Ogun State, Nigeria*



### **Abstract**

*For any organization to succeed, it should be able to compete within its market, and attempt to rub shoulders with other competitors in the international frontiers. The study seeks to investigate the effect of technological innovation of organizational performance of Dangote Plc, Ibese Plant, Ogun State. The objective of the study was decomposed to find out the impact of Strategic planning capability & Marketing Planning Capability on Organizational Performance. A descriptive survey design was adopted for this study. Sample sizes of 96 employees in the study area were conveniently selected by the researcher to aid effective result. A structured questionnaire was utilized to collect the needed data from the respondents. The collected data was analysed using simple percentage statistics while the hypotheses were tested using linear regression analysis. The finding of the study revealed that strategic planning capability and marketing capability have positive relationship with organizational performance ( $p= 0.000$ ). Following the findings of the study, it was recommended that there should be pragmatic strategic planning capability in order to deliver superior performance and ultimately sustained competitive advantage.*

**Keywords:** *Innovation, Marketing Planning, Organizational performance, Strategic Planning, Technology*

### **Introduction**

Technological innovation is more and more important for an organization in a competitive and dynamic environment. Technology, as an intangible asset, is becoming a critical factor for the survival and competition among companies. Zahra & Bogner (2000) suggest that technological innovation may have an impact on the industry's structure or competitive advantage, as well as being an important edge for a company willing to challenge a well-established competitor. Therefore, the widespread application of technology can be an important factor in structuring an industry, technological innovation can provide a

competitive advantage for a company or even increase the profitability of all the companies within the industry.

For any organization to succeed, it should be able to compete within its market, and attempt to rub shoulders with other competitors in the international frontiers. The organization must imbibe the culture of innovation because of its importance as confirmed in many studies (Daniels, 2002; Gelende & Fuente, 2003). Information technology may not have been optimally utilize to assure strategic planning capability. Product innovation may also not have enjoyed a lot of attention and this may have an effect on marketing capabilities.

Unfortunately, Nigerian manufacturers find it difficult to stand against its competitors from foreign countries. The local companies cannot compete with the foreign counterparts in terms of product quality and other areas of marketing capabilities.

The foreign firms have strategic plan as a tool-kit for achieving their feet, which is also lacking among the domestic manufacturers. The resultant effect is while the local industries performance is on the decline, the multinationals are booming.

The broad objective of the study is to evaluate the impact of technological innovation on Organization performance.

In order to pursue the broad objective of this study, the following hypothetical statements are put forward to give a direction to this study:

H01: Information technology does not have any effect on strategic planning capability

H02: Product innovation does not have an effect on marketing capabilities.

## **Conceptual Review**

### **Technological Innovation Concept and Innovation Process**

Technological innovation is underdetermined – there is no single “best solution”. To state that technological innovation is underdetermined is to say that “technical principles are insufficient by themselves to determine design” Feenberg, (1995). The research traditions mentioned above subscribe to the view that the “natural attributes” of technology are not sufficient to explain technological innovation, though they differ in the importance they attach to this belief. For the social shaping of technology theorists, the belief that technological innovation does not unfold according to some predetermined technical logic is critical (Williams & Edge, 1996). The particular path that technological innovation takes is something to be explained, rather than simply adjusted to. Studies of the management of innovation, and innovation adoption, acknowledge that the seemingly “best” technology does not always become the most widely accepted Utterback, (1994).

While the economists of innovation believe that technological “trajectories” make some innovation paths more likely than others (Dosi, 2005), the complex interplay between technological supply and market demand cannot be captured strictly with reference to the characteristics of technology. Even in the literature on technology and organization structure, which has argued for the strongest links between the nature of technology and organizational forms, there is a recognition that technological change serves as an occasion for restructuring Barley, (2000), and the same technology can occasion quite different organizational outcomes.

Technological innovation cycles between periods of stability and change. A wide range of technological innovation research suggests that the innovation process fluctuates between periods of relative stability and periods of relative change. Research on innovation and business strategy in particular has argued that the nature of innovation changes over time. Periods of more incremental innovation, in which technology appears to develop along well understood paths, are then abruptly followed by periods of more radical innovation, in which the certainties of the past era are abandoned Utterback, (1994); Tushman & Rosenkopf, (2002).

### **The Meaning and Scope of Organization**

Organization is defined in a number of ways. In the study of management, it can refer to the structure of relationships among individuals. A less static approach defines organization as a process or an element of management concerned with change or growth of the structure. So, Organization can be defined as a collection of people working together in a division of labour to achieve a common purpose.

The aim of any organization is to produce a good or service. Large and small businesses produce consumer goods and services such as automobiles, appliances, gourmet dining, and accommodations. Non-profit organizations produce services with public benefits such as health care, education and judicial processing. A clear statement of aim is important to guide the activities of an organization and its members.

To achieve its aims, organizations depend on the activities and collective effort of many people. At this respect, people are the main human resources of organizations - the individuals and groups whose performance contributions make it possible for the organization to serve a particular purpose. However, organizations need more than people if they are to achieve their aims, to survive and prosper. They also need material resources including physical equipment and facilities, technology, information, raw materials and money. Organizations require all of these resources in order to produce some useful goods and services.

### **Organizational Performance**

Measuring organizational performance is difficult (Hubbard, 2009). Numerous literatures exist on organizational performance. The earliest research on this topic developed what was known as the shareholders theory. They viewed firms as belonging to shareholders and as such, they concluded that organizational performance can be measured only in terms of shareholders' returns. This theory agrees with the belief of Prof Milton Friedman who stated that 'the business of firms is to make profit' (Porter, 1980; Owen, 2006; Brown & Fraser, 2006).

Organization performance has been defined as the capability of firm to accomplish its goals and objectives with the help of talented administration, good governance and have a constant rededication to accomplish business objectives Mahapatro, (2013). Organizational performance is a sign which deal how well a business complete its goals. Organizational performance is one of the most key constructs in the research of management (Ho, 2008).

Owen (2006), in agreeing with the shareholders' theory believes that organizational performance encompasses three specific areas of firm outcome: (a) Financial Performance (profits, return on assets, return on investment etc), (b) Product Market Performance (sales, market share etc.) and (c) Shareholders Returns (total shareholders return, economic value added etc.)

The 1990s saw the emergence of the Stakeholders theory (Hobbar, 2009). This theory sees the firm as responsible not only to shareholders, but also to a wider group which includes employees, representatives, customers, suppliers, government, industries, bodies, local communities etc. As such, its performance must be measured by how much it is able to satisfy these stakeholders (Freeman, 1984; Reich, 1998; Post, Preston, & Sach, (2002); Brown & Fraser, 2006; Steuer, 2006). The stakeholder theory assesses organization performance against the expectation of a variety of stakeholder groups that have particular interest in the effects of the organization's activities. Its perspective of organizational performance incorporates stakeholder value, but recognizes that shareholders are just one group of stakeholder and only relevant to those organizations that issue shares (Hubbard, 2009).

Another concept of organizational performance based on the stakeholders' perspective is the Balanced Score Card (BSC). This incorporates financial, customer/market, short term efficiency and long-term learning and development factors into the measurement of organizational performance.

### **Theoretical Review**

#### **Unified Theory of Acceptance and Use of Technology (UTAUT)**

This study is anchored on the Unified Theory of Acceptance and Use of Technology (UTAUT) posited by Vankatesh, Morris, Davis & Davis (2003). The UTAUT model intends to explain

technology acceptance and it is based on eight technology acceptance theories or models. Particularly, the UTAUT extracts from the Theory of Reasoned Action (TRA), the Technology Acceptance Model (TAM), the Motivational Model, the Theory of Planned Behaviour (TPB), the combination of TAM and TPB, the model of Personal Computer Utilization, the Innovation Diffusion Theory and the Social Cognitive Theory (Vankateshet *et al.*, 2003). Centrally, the UTAUT model uses behavioural intention as a predictor of the technology use behaviour. The behavioural intention predictors that are included are based on the components of the eight technology adoption models reviewed.

Adding to behavioural intention and use behaviour, the UTAUT model comprise of four constructs which are performance expectancy, effort expectancy, social factors and facilitating conditions. The model also includes four moderating variables: age, gender, education and voluntaries of use. In the model, performance expectancy and effort expectancy and social factors directly affects behavioural intention which along with facilitating directly affects use behavior.

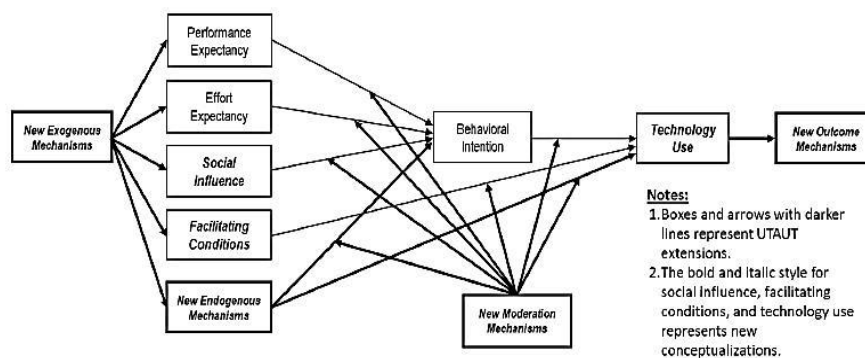

**Source:** Venkatesh et al. (2003)

### Empirical Review

Empirical evidence which connects innovation with organizational outcomes such as financial performance abounds in literature. In the study of a business operating in Istanbul, Turkey, Gokmen and Hamsioglu (2011) discovered the existence of a relationship between innovation and organizational performance. Lim, Schultmann and Ofori (2010) studied the effect of innovation on performance of construction firms using data statistical data across 18 Organization for Economic Cooperation and Development (OECD) countries and expert interviews in Singapore. They discovered that due to the fact that construction projects are awarded by clients based on lowest cost, innovation appears to be an unfeasible competitive strategy. However, their study revealed that construction firms can develop their competitive advantage through manipulating innovations that consumers are willing to pay for and

innovations that would reduce construction costs. They also recommended that construction firms first utilize quality improvements to exploit consumers' willingness to pay for innovative products. This initiative would enable construction firms to improve their finances for innovation and develop their "brand" in construction products. Sustainable competitive advantage could then be firmly established when construction firms engage in productivity improvements that lead to lower construction costs and/or faster completion times.

Yam, Guan, Pun and Tang (2004) state that technological innovation is the skill involved in realizing and supporting a company's technological innovation strategy, As such, it is a specific asset or resource which includes technology, products, expenditures, processes, knowledge and experience. In their study, they also propose seven dimensions for measuring technological innovation which are: technological learning, R and D, resource allocation, manufacturing ability, marketing skill, organizational skill, and strategic and scale related ability. Archibugi& Coco (2005) point out that technological innovation is the ability to access and digest external knowledge into some unique skill or knowledge, then using it in a dynamic way to improve or develop a new product and launch it successfully. Therefore, it includes capability in product, process and personnel technology.

### **Methodology**

The study adopted a survey research design which measured two variables, dependent and independent variables. The independent variable is technological innovation which was measured by sub-variables information technology and product innovation while the dependent variable organizational performance was measured by strategic planning capability and marketing capability.

The population of the study is the management staff of Dangote Plc (Ibese branch) which consists of 448 staffs which include the top management staff, senior staff and junior staff. The sample size was calculated using the sample size determination for research activity by Taro Yamane. In estimating the sample size, a 5% margin of error (confidence interval) was used. The sample size for the study therefore is ninety six (96).

The next question borders on how the researcher will select 96 management staff out of the population. This question leads us to sample selection method appropriate for this study with respect to selecting the management staff. In this study the probability (or random) sample shall be used because we want every unit (that is management staff) of the study population to be given an equal chance and known probability of being represented in the sample.



The data for the study were collected using both primary and secondary source of data. Primary source of data involves the use of questionnaire, some secondary sources data which include textbooks, journals and online article were also consulted during the literature review.

The copies of the questionnaire were distributed to the management staff and the information so collected formed the thrust of the data analysis. Content validity was used for the current study. Cronbach’s alpha method of reliability is used for measuring the reliability of this research work. Descriptive statistics which involves the collection, presentation and characterization of a set of data in order to properly describe the various features of that set of data was employed. Hence extensive use of percentages was made.

Also, simple linear and multiple regression analysis in respect to the study hypothesis were used to measure the degree of effects of independent variables on the dependent or outcome variables. After distributing the questionnaire, data would be collected, coded and analyzed through the use of the Statistical Package for Social Science (SPSS). Regression analysis and descriptive statistics would be used to validate the data.

## Results and Discussion

**Table 1:** Reliability Statistics

Cronbach's Alpha	N of Items
.738	18

**Source:** Researcher’s Compilation from SPSS

The Cronbach alpha reliability test shows the result of the reliability test of the responses of the respondents to the returned questionnaire, the result shows the Cronbach alpha value of 0.738 which indicates that the respondents responses is highly reliable.

**Table 2:** Model Summary<sup>b</sup>

Model	R	R Square	Adjusted R Square	Std. Error of the Estimate	Durbin-Watson
1	.400 <sup>a</sup>	.160	.142	.67309	1.911

a. Predictors: (Constant), Product Innovation, Information Technology

b. Dependent Variable: Organizational Performance

**Source:** Researcher’s Compilation from SPSS

The table above shows the R square with the value of .160% which indicates that 16.0% variation in organizational performance is caused by the explanatory variables which include Product innovation and Information technology. Also, the adjusted R square indicates that after adjusting the degree of freedom, the explanatory variables can still explain 14.2% variation in the organizational performance. However, the table further reveals the Durbin Watson statistic with the value of 1.911 which indicates that there is no serial auto correlation among the variables.

**Table 3:** ANOVA<sup>a</sup>

Model		Sum of Squares	Df	Mean Square	F	Sig.
1	Regression	8.022	2	4.011	8.854	.000 <sup>b</sup>
	Residual	42.134	93	.453		
	Total	50.156	95			

a. Dependent Variable: Organizational Performance

b. Predictors: (Constant), Product Innovation, Information Technology

**Source:** Researcher's Compilation from SPSS

The F statistic table reveals the overall significance of the model, the probability value of 0.000 which is below the level of significance indicate that we reject null hypothesis and conclude that technological innovation has significant impact on organizational performance.

**Table 4:** Coefficients<sup>a</sup>

Model		Unstandardized Coefficients		Standardized Coefficients	T	Sig.
		B	Std. Error	Beta		
1	(Constant)	1.115	.300		3.713	.000
	Information Technology	.405	.097	.399	4.190	.000
	Product Innovation	.050	.093	.051	.540	.591

a. Dependent Variable: Organizational Performance

**Source:** Researcher's Compilation from SPSS

The coefficient table reveals the relationship between the variables which shows that the variables have a positive relationship with organizational performance with 0.405 and 0.050. The table further reveals the significance of the explanatory variables which was however

used to test the hypotheses of the study. However, the table reveals that information technology is statistically significant with probability value of 0.000 while product innovation is not significant with probability value of 0.591 with organizational performance at 5% level of significance.

**Table 5:** Coefficients<sup>a</sup>

Model		Unstandardized Coefficients		Standardized Coefficients	T	Sig.
		B	Std. Error	Beta		
1	(Constant)	1.549	.275		5.634	.000
	Information					
	Technology	.195	.121	.164	1.607	.111

a. Dependent Variable: Strategic Capability

**Source:** Researcher's Compilation from SPSS

The table above reveals the significant of the variable as well as the relationship between the dependent variable and the predictor. The coefficient result shows that information technology has a positive relationship with strategic capability with the value of 0.195. The significance value of information technology at 0.111 corroborates the conclusion that information technology does not have a significant effect on strategic planning capability employed by organizations.

**Table 6:** Coefficients<sup>a</sup>

Model		Unstandardized Coefficients		Standardized Coefficients	T	Sig.
		B	Std. Error	Beta		
1	(Constant)	1.457	.234		6.231	.000
	Product					
	Innovation	.314	.104	.298	3.024	.003

a. Dependent Variable: Marketing Capability

**Source:** Researcher's Compilation from SPSS

The table above reveals the significant of the variable as well as the relationship between the dependent variable and the predictor. The coefficient result shows that product innovation has a positive relationship with marketing capability with the value of 0.314. The significance

value of product innovation at 0.003 corroborates the conclusion that product innovation has a significant effect on marketing capability employed by organizations.

**Table 7:** Correlations

		Information Technology	Marketing Capability	Product Innovation	Strategic Capability
Information Technology	Pearson	1	.302**	-.037	.164
	Correlation		.003	.720	.111
	Sig. (2-tailed) N	96	96	96	96
Marketing Capability	Pearson	.302**	1	.298**	.242*
	Correlation	.003		.003	.017
	Sig. (2-tailed) N	96	96	96	96
Product Innovation	Pearson	-.037	.298**	1	-.094
	Correlation	.720	.003		.365
	Sig. (2-tailed) N	96	96	96	96
Strategic Capability	Pearson	.164	.242*	-.094	1
	Correlation	.111	.017	.365	
	Sig. (2-tailed) N	96	96	96	96

\*\* . Correlation is significant at the 0.01 level (2-tailed).

\* . Correlation is significant at the 0.05 level (2-tailed).

**Source:** Researcher's Compilation from SPSS

The correlation table shows the relationship between the variables. However, the table shows that information technology has a positive correlation with marketing capability and also statistically significant at 0.05 level of significance. Also, the table reveals that information technology with 0.037 has a negative relationship with product innovation and not statistically significant at 0.05 level of significance. The table further reveals that information technology has a positive but low correlation with strategic planning capability and also not statistically significant at 5% level of significance. Also, marketing capability has a positive relationship with product innovation and also statistically significant with probability value

of 0.003. Furthermore, marketing capability has a positive relationship with strategic capability but not statistically significant. Finally, the table shows that product innovation has a weak negative relationship with strategic capability and also not statistically significant with significance value of 0.365.

### **Test of Hypotheses**

#### **Hypothesis I:**

**H<sub>0</sub>:** Information technology does not have any effect on strategic planning capability

**Decision Rule:** The coefficient table shows that strategic capability and marketing capability with probability value of 0.111 is not statistically significant which denote that we accept null hypothesis and conclude that Information technology does not have any significant effect on strategic planning capability.

#### **Hypothesis II:**

**H<sub>0</sub>:** Product innovation does not have an effect on marketing capabilities.

**Decision Rule:** Product innovation with probability value of 0.003 is statistically significant which means that we reject null hypothesis and conclude that product innovation has a significant effect on marketing capabilities.

### **Conclusion**

This research work examined the extent to which technological innovation affect organizational performance in manufacturing industries with particular focus on Dangote Cement Plc. The findings of the study revealed that the explanatory variables which include information technology and product innovation have positive relationship with organizational performance. The research concludes that there is need for high usage of information technology in order to increase the performance of an organization. Similarly, product innovation has to be increased in an organization in order to enhance performance.

Finally, the explanatory variables which include information technology and product innovation used to measure technological innovation while strategic planning capability and marketing capability which was used to measure organizational performance reveals that there is positive relationship among the variables at a significance level of 0.05. Thus, the study corroborates the assertion that there is need for technological innovation (which serves as a driving force) in an organization.

### **Recommendations**

Based on the above findings, the following recommendations are discernible:

1. Manufacturers should be innovative about their technology so that they can be competitive in the market.
2. Organizations should train and re-train their employees so that they can master new innovation in order to be more productive, which will lead to better performance.
3. There should be pragmatic strategic planning capability in order to deliver superior performance and ultimately sustained competitive advantage.
4. The management of Dangote Plc should embrace marketing capability that can help in the effective and efficient management of marketing mix

### References

- Archibugi, D., & Coco, A. (2005). Measuring technological capabilities at the country level: A survey and a menu for choice, *Research Policy*, 34, 175-194.
- Barley, S. R. (2000). The alignment of technology and structure through roles and networks, *Administrative Science Quarterly*, (35), 61-103.
- Brown, J., & Fraser, M., (2006). Approaches and perspectives in environmental accounting: An overview of the conceptual landscape, *Business Strategy and the Environment*. (15), 103- 117.
- Daniels, E (2002). The dynamic of product innovation and firm competences, *Strategic Management Journal*, 23, 1095-1125.
- Dosi, G. (2005). Technological paradigms and technological trajectories: A suggested interpretation of the determinants and directions of technical change. *Research Policy*, 11, 147-162.
- Feenberg, A. (1995). *Alternative modernity: The technical turn in philosophy and social theory*. University of California Press, Berkeley, CA.
- Freeman, A. (1984). *Strategic management: A stakeholder approach*, Pitman: Bolton, M. A.
- Galende, J., & Fuente J. M. (2003). Internal factors determining a firm's innovative behaviour, *Research Policy*, (32), 715-736.
- Gokman, A. & Hansioglu, A. B. (2011). Tacit knowledge and its correlation to innovation and performance in obtaining competitive advantage: A study in a business operating in the textile industry, *International Journal of Economics and Administrative Studies*. 4 (7), 19 - 34.

- Ho, L. A. (2008). What affects organizational performance? The linking of learning and knowledge management, *Industrial Management & Data Systems*, 108 (9), 1234 - 1254.
- Hubbard, G. (2009). Measuring organisational performance: Beyond the triple bottom-line, *Business Strategy and the Environment*. (18), 177 - 191.
- Lim, J. N, Schultmann, F. & Ofori, G. (2010). Tailoring competitive advantage derived from the needs of construction firms, *Journal of Construction Engineering and Management*. 568 - 580.
- Mahapatro, B. B. (2013). *Organizational performance: Human resource management*, 272- 279.
- Owen, D. (2006). Emerging Issues in Sustainable Reporting. *Business Strategy and the Environment* (15), 241 - 218.
- Porter, M. (1980). *Competitive Strategy*. Freeman Press, New York
- Post, J., Preston, C., & Sach, S. (2002). *Redefining the Corporation: Stakeholder Management and Organisational Wealth*. Stanford University Press, Pato Alto.
- Reich, R. (1998). The New Meaning of Corporate Fiscal Responsibility. *California Management Review* 40 (2), 8 - 17.
- Steuer, R. (2006). Mapping Stakeholder Theory Anew: From the Stakeholder Theory of the Firm to Three Perspectives of Business-Society Relation. *Business Strategy and the Environment* 32 (15), 55 - 59.
- Tushman, M.L., & Rosenkopf, L. (2002). Organizational Determinants of Technological Change: Towards a Sociology of Technological Evolution. *Research in Organizational Behavior*. 6 (14), 311-347.
- Utterback, J.M., (1994). *Mastering the Dynamics of Innovation*, Harvard Business School Press, Boston, MA.
- Venkatesh, V., Thong, Y., & Xu, X. (2012). Consumer Acceptance and use of Information technology: extending the Unified Theory of Acceptance and Use of Technology (UTAUT). *MIS Quarterly*, 36(1).157-178.

Williams, R.E., (1996). *The Social Shaping of Technology*", in Dutton, W (3<sup>rd</sup>eds), *Information and Communication Technologies: Visions and Realities*.Oxford University Press, New York, NY.

Yam, C.M., Guan, J.C., Pun, K.F., & Tan, P.Y. (2004). *An Audit of Technological Innovation Capabilities in Chinese firms: Some empirical finding in Beijing, China*. *Res. Policy*, 21(33), 1123-1140.

Zahra, S.A., &Bogner, W.C. (2000). *Technology Strategy and new Venture Performance: Examining the Moderating role of the Firm`s e-competitive Environment*. *J. Bus. Venture*, 6(15), 135-173.



## PARTICIPATORY POLICY PROCESS AS ROAD MAP TO ECONOMIC DEVELOPMENT: A STUDY OF NIGERIA

<sup>1</sup>Mutiulla Adebayo Olasupo & <sup>2</sup>Anyanwu, Christianus Izuchukwu

<sup>1</sup>Department of Political Science and International Relations,  
University of Abuja

<sup>2</sup>Department of Political Science and Diplomacy,  
Veritas University, Abuja



### Abstract

*Participatory policy process in Nigeria is commonly known to be dominated by elites, and control all stages of policy process. With regards to this, citizens are denied the right to contribute in policy process, thereby taking by surprise at implementation stage. Given to the fact that policies produced from true sense of participatory process stand the chance of adoption and support, the gap this denial creates makes citizens to withhold compliance, or in some cases outrightly stand against such policies. This is because they perceive such policies as alien to them, even when the policies could make direct impact in their livelihood. As such, this scenario has negative impacts on economic development of the country. This paper argued that the Nigerian policy environment is not democratized for citizens' participation. Thus, policy making process has remained fundamentally elites dominated and its environment is largely repulsive to engaging citizens in the country's quest for economic development. Since modern economic development is citizen driven, and utilizing secondary source of data, the paper recommended a participatory policy process that will give the citizens sense of belonging, perceiving such policies as their initiatives, and reinvigorating their patriotic spirit towards realizing economic development. The paper adopted structural-functionalist approach for analysis.*

**Keywords:** *Public policy, Participatory policy process, Economic development, Structural-functionalist approach.*

### Introduction

Over the years, the practice of public participation has gained serious attention from scholars and researchers alike. This is predicated on the important role it plays in the human society. The practice of citizen participation can be traced to ancient Athenian political society where every individual citizen is important in decision-making process. In the ever-growing trend toward domestic and global democracy, citizen participation has stood as a foundation of any society that wishes to attain maximum security, equity and economic development. There is

rise in demand for participatory process in public policy and decision-making. This is evident when Menegat (2002, cited in Meno 2016, p.1) holds that over 1,500 cities around the world have adopted participatory budgeting process. It is in recognition of this trend that the American Institute of Certified Planners (AICP) list serving the public interest as planner's primary obligation within their code of Ethics and Professional Conduct, (American Institute of Certified Planners, 2009). As a matter of importance, the code specifically advocates for inclusivity stating that people should have the opportunity to have a meaningful impact on the development of plans and programmes that may affect them. By this it means that participatory process should be broad enough to accommodate those who do not wield power or influence.

This idea should be central in policy-making process. This is owing to the fact that policy is a general plan of action adopted by government to solve societal problems. The Nigerian policy-making environment is characterized by various group and individual interests competing for relevance and supremacy. Thus, policy-making process becomes an affair of the ruling elites who wield power and influence against the general citizens. With this, policy environment in Nigeria suffers from policy imposition, hasty adoption, lack of public goal, elite dominance, lack of social acceptance, non-continuity, lack of clear definition and coordination, and compromise at implementation stage.

This scenario has generated lack of trust and confidence by citizens on the government and their policies, thereby creating a gap between the government and the citizens. The missing link in the support and compliance of citizens to government's economic policies, to a great extent retard progress in economic development of the country. Ihedinihu (2016, p.13) contends that irrespective of how good economic policy of Nigeria is, the citizens whom economic activities and development are largely dependent on are not willing to comply with the stipulation of the policy as the policy-making process is shut against them. Ihedinihu further argues that this reoccurring situation has led to many policy adjustments, and discontinuation or policy abortion. Waziri (2009, p.35) holds that, the selfish desires and protection of personal and selected interests form the basis for policy priority setting, as against the clearly articulated needs of the citizenry. This has over the years produced leaders that have plundered the common wealth of the people rather than apply same to their development.

This explains why there is no significant record of economic growth which is driven by the citizens. Economic growth leads to economic development, therefore to achieve economic development is largely dependent on inclusive policy process which is the thrust of this paper.

### **Statement of Problem**

Policy is seen as a tool government uses to respond to social demands, and administer the affairs of the people. This means that policy is meant for the betterment of the citizens. It is naturally expected that as such, the inputs of the citizens are needed, thereby carry them along in the policy process.

Nigeria as a nation has experienced policy and economic sabotage, where citizens and group of individuals work against economic policies and directives of the government. This has led to poor economic growth, and consequentially low level of economic development. This paper therefore investigates the impact of participatory policy process on economic development with focus on Nigeria.

### **Research Objective**

The objectives of the paper are as follows:

- 1) To ascertain if there is participatory policy process in Nigeria.
- 2) To investigate the impacts of participatory policy process on economic development.
- 3) To identify means through which economic development can be realized.

### **Concept Clarification**

Concept clarification is important especially in social sciences which has often formed the fulcrum of academic research. This is because it sets the parameter within which concepts are used in a given context.

Public Policy is a way of dealing with public problems or a sort of concrete socio-economic action or response to weakness and inability of private sector to supply necessary goods and services or a response to a missing link within the norms of the society, (Larson, 1985, p.27). This definition sees public policy as a reaction by government to intervene against social anomaly within the society. Appleby (1984, p.66) defines public policy in a more concise way, for him it is a guide to the action or decision of the people. This view underscores its relevance in guiding or directing the conduct of individual and human organizations. Such action prevents the society from sliding into state of anarchy. Government in its wisdom knows when and where to intervene. This is captured in Dye's (2011, p.14) definition, that public policy is whatever government chooses to do or not to do. By this, it means that, silence of government is also a policy. Public policy therefore serves as a framework put forward to guide a person or group of persons in the conduct of a particular task. It is in this view that Anderson (2007, p.1) asserts that public policy is a goal directed or purpose course of action followed by an actor or set of actors in an attempt to deal with public problems. This definition emphasizes that public policy is target or goal oriented. In a similar vein, Robert and Clark (1982, p.61) considered public policy from goal attainment and power configuration point of view. For them, public policy making process refers to series of steps taken by a government

to solve problems, make decisions, allocate resources or values, implement policies and in general to do the things expected of them by their constituencies. This view underscores the indelible link between public policy and the people. Ikelegbe (1996, p.80) echoes this in his definition that public policy is the integrated courses and programmes of action that government has set and the framework or lead by planned to direct actions and practices in certain problem areas.

**Participatory Policy Process** - In an attempt to explain the concept of participatory policy process, it would be necessary to first define the concept of participation. Though Vroom and Jago (1988, p.18) contend that participation is subject to ambiguous and diverse interpretations. This is seen where participation is the term used to designate the involvement of citizens in contributing ideas toward the solution of problems affecting them and the entire human society. Bekker (2012, P.27) was precise to view this as an activity undertaken by one or more individuals who were previously the sole protagonists in the process. However, this definition is not all inclusive.

Specific interpretations can be made within the context of policy-making process. Participation in this regard is a means to an end and not an end in itself. It is an activity undertaken by policy actors involving the citizens for logical realization of goals. It is a deliberate and goal-oriented activity of government. This is because the process or activities in which the citizens participate with various institutions are goal-oriented. Therefore, citizen participation is viewed as citizen's involvement in a wide range of activities that relate to the policy-making process establishing the legitimacy and acceptance of the policy with certainty of compliance and cooperation. Langton (1978, p.21) in a similar way view this as purposeful activities in which citizens take part in government related activities. This shows that policy makers should rely on citizens' inputs to stay informed about public concerns as well as to gain insight into citizens' preferences. This creates ground for variety of opinions and options, generation of a sense of project and programme ownership and feeling of civic pride. Furthermore, citizen participation ensures the principle of checks and balances, preventing abuse or misuse of administrative authority and political power. This notwithstanding, citizen participation has its shortcomings, it is bureaucratic and time consuming, costly and slow, and it can as well evoke a negative reaction if citizens' inputs are not taken, (Langton, 1978, p.25). Be it as it may, citizen participation remains the way to go, as it is more protective and assuring, promoting good governance, effective policies and economic development.

### **Theoretical Framework**

This paper adopted structural-functionalist approach which is relevant in this context and provides a more comprehensive theoretical framework for analysis of the participation and functional relation between the citizens, government and policy process within a system. The

theory was first identified with Emile Durkheim in sociology discipline and later adopted in the field of political science. It aims at providing a consistent and integrated theory from which can be derived explanatory hypotheses relevant to all aspects of political system (Lane, 1994, p.68). The structural-functional model is most associated with Parsons (1951) in the field. However, Almond (1969) has restated the scheme so drastically that he has an influence independent of Parsons.

According to Almond's structural-functional analysis, all political system must perform certain requisite functions. He describes societal reality largely in terms of structures, processes, mechanisms and functions. In this model the parts and pieces of an organism contribute functioning of the organism as an entity. The functionalist tradition postulates that social systems meet certain needs and suggests that there are functional imperatives that must be met in order for a group to survive, (Eminue, 2005, p.13). As every part of the system or process plays its roles, they contribute to maintaining the social structure, and achieving the desired results. This alignment of social relations or participation is critical for survival of the society.

Eminue (2005, p.15) identified certain characteristic features embodied in the structural-functionalism approach -

- a) An emphasis on the whole system as the unit of analysis
- b) The postulation of particular function as requisite to the maintenance of the whole system
- c) Functional interdependence of diverse structures within the whole system

### **Application of the Theory**

By this framework the state is conceived as a system while the government and the citizens are structures or units within the system. The government being part of the system has function or responsibility of championing policy making process, while the citizens have the civic role to play in the policy process. The citizens whose interest are directly or indirectly represented by institutions like - Civil Society groups, Organized Pressure Groups, Political Parties are viewed as parts of the system (the state) should be involved in the policy making process. Each of these structures performs explicitly specific requisite functions through their inputs which contribute to the stability, continuity and success of the policies. While the government provides the framework for policy making, the people as a unit of the system are expected to make their inputs.

According to Almond (1969, cited in Eminue, 2005, p.17), the various structures or parts of a system are interdependent through their structural and functional relationship for realization of the goals. This brings to clarity the necessary mutually interdependent relationship that

should exist between government and the people in the policy making process. Here, the people need the government to provide the framework for policy making, while the government needs the people for policy inputs, acceptance and compliance to realize the goals of the policy.

The government is empowered by law to spearhead policy making process and is therefore expected to necessarily collaborate for an inclusive policy process so as to achieve the intended objectives which in this context is economic development. The theory assumes that every structure within the system must perform its function for the survival of the system. This simply means that for economic policies to realize its targets of economic growth and development, the people as a structure must be part of the policy process for the ultimate survival of the state.

### **Participatory Policy Process in Nigeria**

The formulation of economic development policy and indeed other public policies have been the responsibility of actors in the public policy space. The actors, for Ujo(2011, p.11) can be classified into two groups, which are - Formal and Informal. Ujo holds that formal groups are those that operate within the institutional framework of government, while, the informal groups operate outside government. The formal group consists of the legislative, executive and judicial branches of government, and the informal group consists of the political parties, pressure groups and civil society groups and organization.

The above explanation indicate that the formal group is made up of political and bureaucratic elites, while the informal group consist of opposition political parties, pressure groups, and civil societies which protect and project the interest of the people in the policy-making process. In representative democracy, the political and bureaucratic elites are directly involved in the formulation of economic policies. The process becomes participatory when the informal groups are incorporated with the mindset of considering their inputs and interests. This is because the informal groups provide the necessary platform for the participation of the people in the policy-making process. Participation in this regard means the inclusion of the inputs or interests of the people by the formal group in the formulation of economic policy. The inputs or interest of the people in this context means the truly felt needs and yearnings of the people.

Through articulation and aggregation of interests, political parties ensure the interest of the people become inputs in the policy-making process. This is because the interests of the people are enshrined in their party manifestoes which they intend to implement should they win elections. Wonah (2017, p.2) holds that pressure groups influence government policies thereby making the interest of the members and indeed the entire Nigerian society to be considered in the formulation of policy. For Wonah, the civil society group serves as the intermediary

between the government and the people. They project and protect the interests of the people in policy making process.

Osman (2002, cited in Wonah, 2017, p.2) argues that public policy making process is not merely a technical function of government, rather it is a complex interaction process influenced by the diverse nature of socio-political and other environmental forces. These environmental forces that form the policy context lead to the variation in policies and influence the output and impact. Osman further contends that public policy making not only involves the public bodies or public officials as policy actors, rather private or non-official group also play a very active role in policy making. In Nigeria, policy making process is guarded against the inputs or participation of the non-official group who ought to play a very active role in policy making.

In Nigeria, policy making process is guarded against the inputs or participation of non-official groups or informal group, like political parties (especially opposition parties), civil society groups and pressure groups that represents the interests and views of the citizens. This has made government policies to remain suspicious and amounts to non-compliance, support and cooperation from the citizens. This has often led to constant change of policy when there is change in government. Offiong (2007, p.25) captures this as he contend that the policy direction of the government is not clear due to lack of inclusive policy process which has led to economic sabotage. Such scenario undermines every effort towards achieving economic growth and development.

### **Implementation of Participatory Policy Process in Nigeria**

The importance of citizen participation in public policy process cannot be overemphasized. Citizens' participation in public policy process is regarded as one of the milestones of democracy and good governance. Political parties, civil society groups, pressure groups, local government town hall meetings provide an ideal forum and platform for allowing participatory policy process as it is closest to every single individual citizen, for easy realization of inclusiveness for economic growth and development.

Participatory policy process gives credence to its implementation, (Wonah, 2017, p.13). Thus, a public policy proposal should in details explain the objectives, policy instruments and implementation stages and steps which at this stage receive inputs from the people. In realizing this, the citizens will know the policy direction and targets of the government. In the light of their inputs, the people, having given sense of belonging will willingly adopt, support and comply with the policy stipulations. For instance, in the case of economic policy, the people having been fully aware of the policy details through their participation will adjust to the tunes of the policy with sufficient support, cooperation and compliance.

When the people are carried along in policy making process, the realization of the policy goals becomes feasible. Most policies experience over 80% adjustment at the implementation stage, or being out-rightly aborted when the goals are not close to realization is due to no-inclusiveness of the policy process that characterizes Nigerian policy making process. It is a fact that policies are meant for the people directly or indirectly, and as such, can only succeed with their cooperation and compliance. That makes it logical therefore, that for economic policies to achieve its targets of economic growth and development, the policy process must be participatory in structure. This in line with Makinde's (2005, p.23) argument that policy implementation is the process of converting financial, material, technical and the people's inputs into outputs. Edward as stated in Makinde (2005, p.66) holds that policy implementation is a stage of policy making between the establishment of policy (such as the passage of a legislative or regulatory rule) and the consequences of the policy for the people whom it affects. This assertion reiterates the fact that policies have direct or indirect input on the people. The statement emphasizes on the need to carry along the people whom the policy affects.

Makinde (2005, p.67) further contend, that communication is an essential ingredient for effective implementation of public policy. This communication should begin with the people and the implementers from the stage of formulation to its implementation. On the part of policy implementers, this will prevent inaccuracy and inconsistency in the implementation process. If this is not handled properly, it will result to usual vehement repulsion and revolt from the people. It is on this that Makinde quickly noted that stripped of all technicalities, implementation problem in most developing nations is the problem widening gap between intention and result, which leads to policy failures. The fundamental reason for the policy failures cannot be farfetched, the absence of participatory policy process. In most cases, policy emanates from government rather than the target groups. And by implication, the target beneficiaries are not allowed to contribute to the formulation of the policies that affect their lives, (Wonah, 2017, p.4).

### **Public Policies that Failed in Nigeria**

Hornby (2010, p.34) maintains that since 1976, many public policies enunciated by successive Nigerian governments have not lived up to their expectations. Some failed few months after their enunciation, while others failed due to multiplicity of reasons. For their failures, most of these policies would have helped in the galvanization of economic and social wellbeing of the citizens. Among the public policies which have failed in the country, Obamwonyi (2014, p.48) identifies and explains these as follows:

1. Operation Feed the Nation (OFN): this policy was formulated in 1976. Its functions amongst others were to provide sufficient food for all Nigerians; to facilitate



agricultural credit from commercial banks to farmers. The policy was abandoned soon after the civilian administration of Shehu Shagari came on board in 1979.

2. Green Revolution: it was formulated in 1979 and used to replace the operation feed the nation. This policy did not achieve the desired results due mainly to structural defects occasioned by political parochialism. It ended up as mere slogan or symbiotic policy.
3. Nigerian Agricultural, Insurance Cooperation: it was formulated in 1987. Its functions include the provision of insurance cover for business engaged in agricultural production. The policy objectives were merged with NICON in 2000. This policy did not see the light of the day before and after it was merged with NICON. It was a policy designed to fail right from its formulation as it was never implemented.
4. National Agricultural Land Development Agency (NALDA): formulated in 1989, with the functions of among others:
  - i. To provide strategic public support for land development.
  - ii. To promote and support optimum utilization of the nation's land resources for the accelerated production of food and fibre.
  - iii. To encourage the evolution of economic size villages
  - iv. To provide gainful income and employment opportunities for rural people.
  - v. To address the special problem of the nation's rural majority etc.

The policy was phased out and its functions performed by the Federal Ministry of agriculture and Rural Development (FMARD)

5. Nigerian Agricultural Cooperative and Rural Development Bank: formulated in 2000, its functions include the provision of credit for the production, processing and marketing of agricultural products.
6. Forestry development Programme: formulated in the year 2000. The objectives include the provision of tree seedlings and other forestry development facilities to local community participants in the country's five ecological zones.
7. Roll Back Malaria: formulated in 2001, the poling was meant to eradicate harmful effect of malaria parasites.
8. National Economic Empowerment Development Strategy (NEEDS): this was enunciated in 2004. This policy evolved from the stand point of Millennium Development Goals of the United Nations to address human development problems. It was also on the basis of Nigeria's long-term goals of poverty reduction, wealth creation, employment generation, good governance and value orientation. All the efforts and purported machineries, put into his policy were wasted as was a mere symbolic policy. It never functioned at any of the three levels of government meant to implement it.

9. Directorate of food, Roads, and Rural Infrastructure: This policy was enunciated in 1986 for the following purposes:
- a) To coordinate and streamline all rural development activities in the country and to accelerate the pace of integrated rural development.
  - b) To promote a framework for grassroots social mobilization
  - c) To amount a virile programme of development, monitoring and performance evaluation
  - d) To provide rural areas with access roads and potable water
  - e) To improve rural sanitization, literacy and technology.

The policy was targeted at the rural areas. It was to make rural areas more attractive to live in so as to stem migration to urban areas. It was also to change for better, the rural ways of life and modes of production in order to meet the challenges of increased agriculture and rural development.

10. Nation Directorate of Employment: this policy was enunciated in 1986 for the following purposes:
- a) To provide vocational skills development programme to secondary school leavers and graduates from tertiary institutions.
  - b) Special public works programme
  - c) Small-scale enterprises programme
  - d) Agricultural empowerment programme

The policy was targeted at the youths in particular so as to provide skill for the unskilled, that to enable the youths acquire vocation. The policy, though still ongoing, is almost in comatose as it is not addressing youth employment and vocational skills. It is not doing enough to stem unemployment and enhance skill acquisition among youths. Many youths are not aware of the policy so as to key into it.

11. Better Life for Rural Women: it was later replaced with the family support programme which became comatose and failed woefully after the regime that enunciated it.
12. National Commission for Nomadic Education (NCNE): it was enunciated in 1989 to provide basic education for nomadic herdsmen and fishermen, train nomadic teachers, provide infrastructure for the nomadic schools. Additional programmes were targeted towards girls' education, women and children in exceptionally difficult circumstances, and adult literacy. The policy was targeted at the nomadic people, particularly those whose occupations are nomadic in nature. The programme was absorbed by the Universal Basic Education policy. But there are no signs that the policy is functioning as planned. This is because the herdsmen who are the real target of the policy are not getting the education they ought to have.

13. Family Economic Advancement Programme (FEAP): enunciated in 1992, it was formulated to provide access to credit for micro entrepreneurs at the grassroots levels; encouragement of job creation, local raw materials utilization, and development of indigenous technology. It was targeted at cooperative societies and informal associations to enable Nigerians have access to credit. The policy has been phased out while the functions were absorbed by the National Agricultural Cooperative and Rural Development Bank (NACRDB).
14. Family Support Programme (FSP): it was meant to promote the welfare of women and children. It was mainly focused on the health needs of women and children. Like the FEAP, the policy has been phased out while the functions were absorbed by the National Agricultural Cooperative and Rural Development Bank (NACRDB). It is also a failed policy.
15. National Commission for Mass Literacy: it was meant to promote adult literacy in the country, especially adults who are illiterate. The policy ought to be absorbed by the UBE, but the policy has gone into oblivion as it has also failed.

### **Participatory Policy Process and Economic Development in Nigeria**

The concept of development can be said to be relative, since there cannot be one precise definition. As a result, it has been defined by various scholars in different ways. In most cases, development has been couched in terms of material things rather than people, in terms of creation rather than revolution, however, true development must mean development of man, (Osita-Njoku, 2016, p.2). This assertion means that every development must translate into the development of man within the society. In other words, man is the beneficiary of development efforts.

Some scholars also argue that development is not merely the construction of bridges and skyscrapers in the cities by the application of foreign technologies, but the development of indigenous skills to exploit local resources for a sustained development process. Okoye (1985, p.35) contends that development should imply not simply an increase in the productive capacity or income which may mean just growth without development, but major transformations in the socio-economic structures whose inequalities and rigidities resulting from outmoded systems, have tended to inhibit all-sided and even development of many third world societies. Okoye went further to hold that development is complex like life itself. This can be seen in the view that development is expressed in terms of output. This view has supported the emerging awareness that the availability of work, the distribution of income and the quality of life are equally important measures of development.

Okediji (1973, cited in Ibe 1989, p.20) summarized his definition of development as a process of initiating societal change so as to improve the capabilities of the institution and values of

communities to meet the increasing and various social cultural, political, economic, and technological demands of its people. In the same vein, Almaric (2007, p.137) maintains that development is a path of societal evolution that combines structural changes with improvement in people's welfare. Following these conceptualizations, one can deduce that development is for people, and not people for development.

Having seen what development is, economic development can simply be defined as the substantial improvement in the economic well-being, and quality of life of a nation, region or local community. This cannot be achieved without economic growth. The positive change or shift in a nation's total output provides the foundation to launch into economic development programmes and policies.

Nigeria has formulated and implemented several development plans among which are – first, National Development Plan 1962-1968, second, National Development Plan 1970-1974, third, National Development plan 1975-1980, and fourth, National development Plan 1981-1985, and these are apart from other national rolling plans of the Babangida military regime, coupled with the unimplemented late Gen. Sani Abacha's vision 2020 within which sustainable rural economic development programmes were encapsulated and constructed as specific projects, (Oyebamiji & Adekola, 2008, cited in Oghenekohwo & Berezi, 2017). Oyebamiji and Adekola further conclude that even in the light of all these development plans and programmes carried in them, they failed grossly; rather than Nigeria achieve economic development she is pushed back into struggling to attain economic growth. The failure is a demonstration of lack of participatory policy process, creating a gap between the policies and the people, whom the policies are made. Oghenekohwo and Berezi (2017, p.8) quickly argues that unfortunately since 1999 when Nigeria returned to civil governance, there seems to be no direct and sustained public policy instruments focusing on economic development.

Before the return of democracy in 1999, various governments in Nigeria since independence have embarked on several economic policies which have been geared towards democratization and development. From indigenization and the era where most of the economic decisions were made by the state, to the era of structural adjustment programme (SAP) in 1986, to privatization, public-private partnership (PPP) to the more emphasized current macroeconomic policies (fiscal and monetary policies) as a mechanism for achieving economic growth and development in Nigeria. These litany of economic plans, policies and programmes for economic development are characterized by huge gap between these policies and the citizens. This is because of non-participatory nature of the policy process, where the people are disconnected, and do not know the policy direction of the government. The attempted participatory policy process of the Structural Adjustment Programme (SAP) experienced abuse and negligence, where the inputs of the people were jettisoned by the then

government which is generally attested to have failed woefully, still leaving economic development unattained.

The recent interest in macroeconomic policies as mechanism for realizing economic growth and development in Nigeria is fueled by the recent fall in the government revenue which is a result of a fall in the international price of oil. Elakhe (2016, p.23) holds that since the sale of oil is the major source of revenue to the government, government expenditure and aggregate demand is drastically affected leading to a very slow growth rate; the exchange rate which was initially stabilized between 155 naira - 160 naira/dollar is steadily increasing. Elakhe further argues that the annual growth rate is as low as the rate of 2.35%, with a volatile external reserve, unstable exchange rate and very slow growth rate due to policy inconsistency and non-inclusive process. This assertion simply explains the disconnection between the people and the policy-making process, which has resulted in poor economic growth, hence non-attainment of economic development.

### **Research Findings**

The paper identified the following:

- 1) Policy process in Nigeria is not democratized, but rather it is elite centered. The policy environment is dominated by the ruling class who influence all the stages of policy cycle.
- 2) Non-participatory policy process has resulted to poor economic growth which has led to low economic development, this is predicated on the fact that people protect policies, programmes and projects they are part of, and sabotage the ones they are not carried along.
- 3) Economic development can be realized through participatory policy process.

### **Conclusion**

Scholars have argued that over years, most policies of the Nigerian society have mostly hinged on self-interest of political leaders. This is the manifestation of the fact that policy process has been under the overwhelming dominance of the political elites, thereby denying the people their civic responsibilities of participating in the policy process. This study identified poor public participation in policy process as a major drawback to achieving policy goals. The target beneficiaries are not involved at the formulation and implementation stages and to this end, do not support, cooperate and comply but rather sabotage the policies. And this is responsible for most policy failures recorded. Unless citizens are carried along in the policy process to reflect the modern trend in contemporary globalized era, achieving policy goals will remain elusive. Waziri (2009, p.38) holds that, the citizenry must be carried along in the various stages of policy planning, decision-making and implementation process, simply because a people oriented project is more likely to succeed as against an imposed project; people especially, the downtrodden of society (the poor and the youth) will always identify

with what they are part of, than what they have no hand in or are not a part of conception. This is why after 50 years of independence and 20 years of democracy, and with the amount of human and material resources in her disposal, Nigeria still struggle to record significant economic growth, rather than economic development.

### **Recommendations**

For Nigeria to attain economic development, the paper recommends in the light of its findings that government at all levels should adopt participatory policy process, from the stage of formulation to the stage of implementation. This should be achieved through:

- 1) Restructuring of policy process against unnecessary rigidity and bureaucratic bottlenecks for easy participation, policy making, and implementation
- 2) Citizens and most especially the direct beneficiaries of any public policy should be encouraged and enlightened on the importance of the policy and the need to participate
- 3) Involving Civil Society Groups, Organized Pressure Groups, Traditional Rulers and political parties for open deliberations, opinions and suggestions for alternative and people oriented policies, and for concerted efforts.

### **References**

- Appleby, O. (1985). *Policy making and policy implementation*, New York: Praeger Publishers
- American Institution of Certified Planners. (2009 October). *AICP Code of Ethics and Professional Conduct*. Retrieved from <https://www.planning.org/ethics/ethicscode.htm> November 15<sup>th</sup>, 2019.
- Anderson, J. (1975). *Public policy making*, New York: Praeger Publishers.
- Bekker, R. (2012). *Public policy development: Linking the technical and political process*. New York: John Wiley.
- Dye, T. R. (1972). *Understanding public policy*, New Jersey: Prentice Hall, Englewood Cliffs.
- Elakhe, E. (2016). *Fiscal and monetary policy and economic growth: A comparative analysis*. Retrieved from <http://www.grin.com> 17/11/19.
- Eminue, O. E. (2005). *Public policy analysis and decision-making*, Lagos: Concept Publications Ltd.
- Hornby, A. S. (2010). *Oxford advanced learner's dictionary of current English*. London: University Press.

- Ihedinihu, O. (2016). Policy making process in Nigeria: Issues, and challenges, *Journal of African Social Studies*. 12 (7), 31-47.
- Ibe, S. O. (1989). *Women participation in rural development: The case of Aboh Mbaise LGA of Imo State in roles and paradigms in the rural development of Nigeria*. Owerri: Karto Press.
- Ikelegbe, A. (1996). *Public policy making and analysis*, Benin City: Uri Publishing Ltd.
- Langton, S. (1978). *Citizen participation in America*. Massachusetts: Lexington.
- Larson, P. (1985). *Planning and policy-making*. Beverly Hills: Sage.
- Makinde, T. (2015). Problems of policy implementation in developing nations: The Nigerian experience, *Journal of Social Sciences*. 11 (1), 63-69.
- Menegat, R. (2002). Participatory democracy and sustainable development: Integrated urban environmental management, *Journal of Environment and Urbanization*. 12 (2), 181- 206.
- Obamwonyi S. E (2014). Public policy failures in Nigeria: Pathway to underdevelopment, *Journal of Public Policy and administration Research*. 9(4) 39-58.
- Offiong, J. O. (2011). The dilemma of implementing effective environmental policies in Nigeria., *Public Policy Administration Research*. 2(5), 20-29.
- Oghenekohwo, J.E. & Berezi, I.U. (2017). Public policy instruments and dynamics of economic development indicators in rural Nigeria, *Mediterranean Journal of Social Sciences*. 8 (5), 1-15.
- Okoye, M. (1985). *Even development: problems and solutions*. Enugu: Dimension Publishing Co. Ltd.
- Osita-Njoku, A. (2016). The political economy of development in Nigeria: From the colonial to post-colonial eras, *Journal of Humanities and Social Sciences*. 21 (9), 9-15.
- Roberts, I. & Clark, P. (1982). *Power and politics in the third world*, New York Santa Barbara: John Wiley and Company
- Ujo, A. A. (2011). *Public policy analysis: A Nigerian perspective*. Kaduna: Anyaotu Enterprises and Publishers.

Vroom, V. H. & Jago, A. G. (1988). *The new leadership: Managing participation in organizations*. London: James Currey.

Waziri, F. (2009). *Leadership and the challenges of good governance in Nigeria*. A paper delivered at the professor Ambrose Alli Annual Lecture/ Awards on the 14th October, 2009.

Wonah, E. (2017). Participation and environmental policy formulation and implementation in Niger Delta Region of Nigeria, *Global Journal of Political Science and Administration*. 5 (1), 1-8



## AN ANALYSIS OF SELECTED EDITORIAL OPINIONS ON THE DISOBEDIENCE OF COURT ORDERS BY THE FEDERAL GOVERNMENT OF NIGERIA

<sup>1</sup>Abati, Mobolaji Oluwaseun & <sup>2</sup>Onifade, Oluwafemi Sunday

Department of Mass Communication,  
Babcock University Ilishan- Remo, Ogun State



### Abstract

*The dearth of effective and selfless leadership has been a major challenge in Nigeria. The standard of leadership across all levels in the country seemingly drops with each dispensation. Although the country returned to democratic rule in 1999, Nigerian leaders have arguably ruled instead of governing the country. There seems to be a culture of impunity across all levels and the political leaders have not been adequately accountable to the people. Government business has been reduced to the personal interest of those occupying public offices. The judiciary is regarded as the hope of the common man, but this maxim is becoming less true with each passing day as the executive selectively obey court judgments and the mass media selectively carries out its constitutional duty of holding the government accountable to the people. This study seeks to evaluate the level of obedience to the rule of law by the Federal Government of Nigeria using the cases of Sambo Dasuki, Ibrahim El Zakzaky and Omoyele Sowore who have been in detention for varying lengths of time. Using the foundation of the Agenda Setting and Framing theories, the paper evaluates the opinion of three Nigerian national newspapers on the cases under review. Critical Discourse Analysis is the chosen method for the conduct of the study. Findings from the study show that the three newspapers under examination have not written an official opinion on the disobedience of court orders by the government.*

**Keywords:** Leadership, Rule of Law, Separation of Power, Media Framing.

### Introduction

Leadership is arguably the biggest challenge of the developing countries especially those in sub-Saharan Africa. Nigeria's development has arguably been stifled by the leaders who have steered the national ship since the country's independence from Great Britain. The giant strides made by the likes of Singapore, Malaysia, Rwanda and Botswana over the last few decades indicate that great things are possible with the political will of selfless and creative leaders.

Politics seems to be the biggest business in sub-Saharan Africa today. Indeed, it should be because the politics drives other aspects of development in a country. Economic, socio-cultural, technological and religious advancements in a country depend on the will of the political leadership of a country. The amount of natural resources available in a country is not a major determinant of the development of the country. The widespread poverty in Democratic Republic of Congo, Nigeria, South Sudan and Angola (countries rich in natural resources) as well as the relatively high quality of life in countries like Switzerland, Israel and South Korea (countries lacking in natural resources) are indications that development is more dependent on leadership and less dependent on natural resources. However, if the right leadership emerges in a country blessed with natural resources, then the opportunities would be limitless. The success of the United Arab Emirates is instructive in this scenario.

One of the hallmarks of democratic governance is the principle and practice of checks and balance. Brennan and Hamlin (1994) posit that if powers are merely separated, that can give those with some powers the ability to act unilaterally to the detriment of others. It demands that each arm of the government checks the excesses of the other arms of government while subjecting itself to scrutiny and guidance by the other arms periodically. This way legislative, executive and judicial excess can be curtailed and the people could get the best of governmental services.

The media is widely regarded as the fourth estate of the realm of governance. The power of the press arose from its ability to withdraw or give out information (McQuail, 2010, p. 168). It is constitutionally empowered to make the government accountable to the people at all times. This constitutional role is however open to interpretation and its interpretation and operation depends greatly on the ownership of each medium of mass communication as well as the socio-cultural and political dynamics operative in the society where each mass medium operates. Consequently, the Nigerian media's interpretation of the disobedience of court orders/judgements by the federal government could vary from one medium to another according to the geographical, political and socio-cultural proximity of each medium to the state and non-state actors involved in the cases adjudicated upon by the Nigerian judiciary.

The present administration has allegedly disobeyed the judiciary on a number of occasions. The public have read reports of these executive disregard for the judiciary and they are likely to explore that precedent in future. Three cases are instructive to this study. They pitch the Nigerian government against a former National Security Adviser, Col. Sambo Dasuki the leader of the Islamic Movement in Nigeria, Ibrahim El Zakzaky and the publisher of Sahara Reporters, Omoyele Sowore. The three individuals have been in the custody of the Department of State Services (DSS) for varying durations and there have been legal battles over their freedoms.

It is important to stress that the greatness of a country is not measured by the amount of natural resources it has, rather it is a product of the quality of leadership in that country. Therefore, each of the three official estates of the realm of governance (legislature, executive and judiciary) as well as the fourth unofficial estate (the media) must perform its oversight functions on other arms to ensure that the leadership are accountable to the people. This is one of the pathways to the cultivation of good leadership.

The immediate past National Security Adviser (under President Goodluck Jonathan) Sambo Dasuki has been in detention since 2015 for allegedly diverting funds meant for the procurement of equipment for the Nigerian military in the fight against the Boko Haram insurgency in the North-East. The allegedly stolen fund amounted to 2.1 billion dollars. Several prominent politicians were also arrested and tried in for allegedly sharing in the money. While the others have been released on bail, the former National Security Adviser has remained in confinement despite judicial ruling granting him bail. He has been granted bail by four High Court judges in Nigeria as well as the ECOWAS court ([www.vanguardngr.com](http://www.vanguardngr.com))

Similarly, the leader of the Islamic Movement in Nigeria Sheik IbrahimEl Zakzaky and his wife Zeenah have been in detention since December 2015 following a face-off between his followers and the Nigerian army. In 2016, a Federal High Court ordered his release from the detention of the Department of State Services ([www.pmnewsnigeria.com](http://www.pmnewsnigeria.com)). The court also ordered the government to pay him the sum of 50 million naira in compensation. The government has failed to follow the directive of the court. The government claims that his continued detention was for his own protection. Following the deteriorating health of Sheik Zakzaky, another court ruled that he should be allowed to travel for treatment abroad and he was reluctantly allowed to go for treatment in India albeit under tight security.

In the third case under review, Omoyele Sowore was arrested on August 3, 2019 in his hotel room ahead of his proposed protest tagged "Revolution Now". He stands accused of treasonable felony, money laundering and cyber stalking President Buhari ([www.pmnews.com](http://www.pmnews.com)). He pleaded not guilty to all the charges and a court granted him bail in September but the DSS refused to release him instead the presiding judge was accused of corruption. The former presidential candidate was re-arraigned in October and another judge granted him bail with stringent conditions. After a while, the defence team met the bail conditions, yet the DSS has failed to release the accused.

### **Statement of Problem**

The federal government of Nigeria has persistently ignored court rulings. This is against the principle of checks and balances and it also sets bad precedents for future Nigerians to disobey court rulings in future. This could potentially lead to the breakdown of law and order in the

society. If that happens, lawlessness and violence could become the order of the day and it would require greater effort to restore the rule of law and public order. The media organizations in Nigeria seem to be subjective tools in the power play between the executive and the judiciary as well as the non-state actors involved in the cases.

### **Objectives of the Study**

The general objective of this study is to examine the representations of the disobedience of court orders by the Federal Government in Nigerian newspapers. The specific objectives are:

1. To examine the disposition of Daily Trust newspaper towards the disobedience of court orders by the Federal Government of Nigeria.
2. To investigate the portrayal of the Federal Government's disobedience of court orders by Vanguard newspaper.
3. To evaluate the Guardian newspaper's framing of the disobedience of court orders by the Federal Government of Nigeria.

### **Theoretical Framework**

#### **Agenda-Setting Theory**

This theory was developed by Maxwell McCombs and Donald L. Shaw in 1972/73 (Lane, 2001). It explains the powerful nature of the media as well as the resultant influence of the media over the users. The summation of the theory is that the media possesses "the ability to tell us what issues are important" (University of Twente, 2014). The media-defined "important issues" are then discussed by the media users until such a time when the media comes up with new agenda. The use of Agenda Setting as a theoretical foundation in political communication can be traced to the concerned of Walter Lippman. As early as 1922, Walter Lippman, a newspaper columnist thought deeply about the effects projected by the media on the minds of the public (University of Twente, 2014) while "as far back as 1922, the newspaper columnist Walter Lippman was concerned that the media had the power to present images to the public McCombs and Shaw investigated presidential campaigns in 1968, 1972 and 1976" (University of Twente, 2014). This present effort hinges on these precedents by using the agenda setting theory as a theoretical base for the discourse on the disobedience of the judiciary by the executive arm of government in Nigeria.

The Agenda Setting theory takes into cognizance the power of individual differences unlike the Magic-bullet theory which claims that people act as they are programmed to do by the media (Baran & Davis, 2012, p. 82). The Agenda Setting Theory says that the media can give the public topics to think about, but it cannot tell the public what to think about the topics. The reaction of the public to the topic (agenda) given by the each medium would depend on the social experiences of the audience as well as the history and reputation of the media organization that is reporting the information (setting the agenda). Therefore, one would expect the various narratives and discourses by the newspapers to generate further discourses

among the readers in the process of impacting on the polity. The resulting impact would therefore be a product of the receptions, perceptions and discourses at different levels rather than a product of the desire and effort of any editorial staff or manager (Onifade, 2015, p. 21). Media owners and professional journalist are closer to the elite class which Eric Louw calls the insiders (Louw, 2005). This closeness gives them the professional freedom and license to determine the topics of public discourse as well as the narratives on them thus making them “symbolic elites”. This elite position provides them with the skills required for the manufacturing of “public knowledge, beliefs, attitudes, norms, values morals and ideologies” (Ademilokun & Taiwo, 2013, p. 442).

### **Framing Theory**

Framing theory was propounded by Erving Goffman who was a sociologist. Framing refers to the manner in which the media packages and presents information to the public. According to the theory, the media highlights certain events and then places them within a particular context to encourage or discourage certain interpretations. In this way, the media exercises a selective influence over how people view reality. Framing is sometimes referred to as second-level agenda setting because of its close relation to the Agenda Setting theory.

In Goffman’s argument, interpretative designs are central to human cultural belief systems. These interpretative designs are the “frames that we use in our day-to-day experience to make sense of the world. Frames help to reduce the complexity of information, but serve as a two-way process: Frames help interpret and reconstruct reality” (Littlejohn & Foss, 2009, p. 407). The core assumption of the theory is that the media draw public attention to certain issues just like the Agenda Setting theory. Framing theory goes a step further than merely setting the agenda by telling people what and how to think about salient issues.

The form in which an editorial content appear is a reflection of the choices made by the reporters, editors and media owner. A frame in this context is the representation of events and issues by media operatives. Frames are “abstract notions that serve to organize or structure social meanings. Frames influence the perception of the news of the audience, this form of agenda-setting not only tells what to think about, but also how to think about it” (University of Twente, 2019, p. 107). In relation to this study, the newspapers under review would present the disobedience of court orders by the executive in different frames depending on the relationship between the publisher and individuals in power.

### **Methodology**

Critical Discourse Analysis is the method preferred for this work. This is because it allows for the critical examination of the motives behind the textual narratives employed in the editorial contents examined.

Daily Trust, Vanguard and Guardian newspapers were purposively selected for the study because of their perceived individual relationships with the Federal Government of Nigeria. Daily Trust was chosen because of its perceived support for the government of President Buhari while Vanguard was chosen for its critical coverage of the activities of the Buhari-led federal government. Guardian newspaper was selected for its perceived higher objectivity on government activities. It thus represents a middle ground.

### **Data Analysis**

The intended unit of analysis for this study is the editorial of each of the newspapers under review. However, the researchers discovered that none of the three newspapers have written an editorial addressing the issue under investigation. They have limited themselves to news stories and personal opinion articles on the detention of the trio of Sambo Dasuki, Ibrahim El Zakzaky and Omoyele Sowore. The failure to publish editorials on the issues could be attributed to the fact that the three detainees are challenging their detentions in court and giving editorial opinions on them could be at the risk of contempt of court. Therefore, the study critically examine some opinion article each in Vanguard and Guardian newspapers respectively and one editorial comment in Daily Trust newspaper.

### **Vanguard Newspaper**

The first entry in this analysis is from the Vanguard newspaper and it is titled "Buhari is ignoring Nigerian judges – We must not let him get away with it" (Olaniyan, 2019). It was published on November 20<sup>th</sup>, 2019. As the title suggests, the piece is in the contempt of the judiciary by Nigerian Presidency. The opinion article is critically examined below. President Muhammadu Buhari's government record on the rule of law is chilling. Since assuming power on May 29, 2015, Mr Buhari has showed a stunning disregard for the rule of law and human rights, ignoring Nigerian judges on at least 40 occasions. And he seems to be getting away with it.

The extract above puts the disobedience of the judiciary by the executive arm of government led by President Buhari in a numerical perspective. Ignoring judicial pronouncements on 40 occasions in less than five years suggests a culture of impunity and sets a bad precedent. The fight against corruption has been an important facet of his rhetoric but his persistent disobedience of court orders, disdain for Nigerian judges and flagrant violations of human rights under his watch puts into question his commitment to actually ending corruption. It's hard to overstate the significance of this disregard of court orders not just for the operation of the rule of law but also effective respect for constitutional and international human rights, such as freedom of expression, peaceful assembly, association and access to information.

Although president Buhari attained the presidency largely on his anti-corruption credentials and rhetoric, the extract suggests that his disobedience of court orders and the persistent

violations of human rights under his watch is a dent on his anti-corruption credentials because opposition to the rule of law is also a form of corruption. Should the president continue on this path, he may undue his legacies in the estimation of right thinking Nigerians and the international community.

Yet, Mr Buhari is carrying on, irrespective of human rights and the rule of law. Any time the courts have told Mr Buhari's government to do something it doesn't like, it has refused to obey it. Even Mr Buhari's attorney general Abukabar Malami, (SAN), once said the rule of law is what the authorities determine it to be. To be clear: it is only an independent and impartial tribunal that has the authority to correct any perceived errors of law of lower courts, not the attorney general.

From the extract above, it is shown that the disobedience of court orders is arguably a state policy given the statement of the Minister for Justice, Abubakar Malami that the rule of law is not enough justification to obey court orders and release political detainees whom he argued had endangered the lives of many Nigerians by their actions in office. He was alluding to the former National Security Adviser, Col. Sambo Dasuki (rtd). In order words, the executive will chose which court judgement to obey and which to ignore which is tantamount to ascribing judicial powers to the executive.

Court orders that are yet to be complied with include those obtained by human rights lawyer and Senior Advocate of Nigeria, Femi Falana, particularly the judgment by Nigerian courts ordering the release of Islamic Movement of Nigeria leader, Sheikh Ibrahim El-Zakzaky and his wife, Zeenah, from unlawful detention. Similarly, the government's State Security Service (SSS) continues to arbitrarily detain activists Mr Omoyele Sowore and Olawale Bakare who called a national protest, in spite of court orders that they should be released on bail and meeting their bail conditions, prompting Mr Falana to tell the government to: "save Nigeria from further ridicule." ([www.saharareporters.com](http://www.saharareporters.com)).

The extract above highlights the other cases which form the tripod for this study. Nigerian courts have ordered the release of Sheik Ibrahim El-Zazaky and his wife but the government has refused to release them. Interestingly, the Minister for Information said that they spend over three million naira feeding them monthly. It would cost them nothing to release them as ordered by the court and the money can be channelled into other areas of the Nigerian society like education or lifting the morale of our soldiers fighting insurgents in the north-east. In the case of Sowore, the government has refused to release him and his co-accused even though they have met their bail conditions. Such actions portend severe danger for the image of Nigerian in the international community.

### **Daily Trust Newspaper**

The second entry for this analysis is an editorial opinion by Daily Trust newspaper titled "Sowore's Revolution". The piece was published eight days after the arrest of Omoyele Sowore an online publisher and activist. The editorial is dissected below:

*The Department of State Security arrested Mr Omoyele Sowore from his home in Lagos last weekend for alleged acts of treason and terrorism. The presidential candidate of the African Action Congress (AAC) in the 2019 general elections and founder of an online leaks newspaper, Sahara Reporters, burnt his fingers by giving a hashtag # Revolution Now to a protest by the Coalition for Revolution (CORE). (Daily Trust, 2019)*

The extract above is the opening paragraph of the editorial. It reveals that the organization had little concern about the plight of Mr Sowore and his co-accused. The newspaper erroneously stated Mr Sowore was arrested from his home. The activist was actually arrested in a hotel ahead of the planned protests slated for August 5, 2019. A national newspaper of repute like Daily Trust should get such important facts accurately. The newspaper also described the activist as the founder of an online leaks newspaper. This is simplistic and reductionist because Sahara Reporters which is published by Mr Sowore does more than leak official secret. It is more of an investigative newspaper than a leak newspaper.

Riding on the crest of the violent imagery that classical revolution evokes, the DSS justified Sowore's incarceration by saying, "These threats include threats of subversion, threat of terrorism and, of course, ethnic agitations, separatist, economic sabotage and others...We must understand the meaning of revolution. Primarily, it means a revolt, it means insurrection, it means insurgency, it means forceful takeover of government and we are operating democratic system in Nigeria."

In the extract above, the editorial board reproduces the reason given by the secret service for arresting Mr Sowore. The editorial fails to give its own interpretation of the words and construct used by the accused which led to his arrest by the secret police. This is an indication that the newspaper is in agreement with the Department of State Service's interpretation of the ideas expressed by the activist.

The CORE claimed to have planned a three-phase protest, none of which alludes to violent overthrow of government. The first stage tagged "end anti-people economic policies," calls for redress in contemporary social issues, like immediate payment of N30,000 minimum wage, putting a stop to the devaluation of the Naira; stop estimated electricity billing; immediate release of El-Zakzaky; payment of outstanding salaries and pensions, etc. The second phase is tagged, "end special privileges for the ruling class," and it calls for a ban on all government officials from using policemen as security guards and sending children to



private schools or foreign universities, etc. The third phase is “returning political power and national wealth to the working people.” Though this is inclined to Socialism, it does not call for an abolition of democracy. One of the aims in this phase is: “to reduce the cost of governance by abolishing the Senate, thus establishing a uni-cameral legislature with only the House of Representatives.”

In the extract above, the editorial board admits that no aspect of the planned protest alludes to the violent overthrow of government. The objectives listed by the group are seemingly in the interest of Nigerians. The demand for the implementation of the new minimum wage, release of unlawfully detained persons like Ibrahim El-Zakzaky and his wife, clearance of backlogs of salaries and pensions are arguably in the interest of the generality of Nigerians. While it is arguable that the second aspect of the protest which aim to stop public officials from having police guards and preventing their kids from attending private schools at home or schooling abroad is an infringement on their human rights, it is a challenge for them to make our society more secure and make our public schools more functional. The quality of public education will be improved if the children and wards of public officials attend these schools. The example of Governor Nasir El-Rufai of Kaduna who recently enrolled his son into a public primary school is unarguably a step in the right direction and it will give the masses greater hope and confidence in the leaders. The editorial also did not give an opinion on the proposal to cut cost by reducing the size of the legislature.

Perhaps, the choice of the word revolution was too extreme or inappropriate for this kind of movement. Revolution could be emotive. Its use in a civil protest could spur participants to engage in acts of violence or sabotage. It may be on this account that the DSS decided to incapacitate Sowore and cripple the attempts to actualize the protest in several cities in the South last week.

From the extract above, it is seen that the newspaper makes a case for the feigned interpretative ignorance of the DSS on the goals of the planned protest. It argues that participants could engage in acts violence during the protest. One major function of the mass media according to Harold Lasswell is the correlation of events for the benefit of members of the society. The editorial therefore ought to have explained the scope and objectives of the planned protest for the benefit of their readers.

We call on the Buhari administration to consider Sowore’s ‘Revolution’ as a wake-up call to the fact that the masses are trapped in the floodgates of difficulties – kidnapping, armed banditry, poverty, unemployment, and general economic downturn...The DSS has dragged Sowore to court and obtained an order to keep him for 45 days. The order is supposed to give security operatives the opportunity for unfettered investigation into CORE’s supposed

unconstitutional acts. We call on the DSS to be thorough and open-minded in this investigation to gather evidence to prove or disprove their hypothesis of terrorism and treason in the #Revolution Now protest. If there is no evidence, they should let Sowore off the hook. The extract above concludes the editorial. The board finally admits that the Nigerian masses are having great difficulties in several aspects of their daily existence. The board members urged the government to do a thorough job in its investigation of the alleged intention and capacity of Omoyele Sowore to violently overthrow the government of President Muhammadu Buhari. They urged the government to release him in the event that the evidences are not stacked against him. Although Sowore mentioned the detention of the likes of El-Zakzaky as one of the reasons why he was leading the protest, Daily Trust kept mute on the continued detention of the Shiite cleric and Smabo Dasuki.

### **The Guardian Newspaper**

The third entry in the analysis is from The Guardian newspaper. It is a personal opinion sent to the newspaper by Kunle Rotimi. It is titled “Dasuki’s case appears suspicious and vindictive” and it was published on October 19, 2016. The entry is analysed below:

*Sir, please let me express my views on the controversial court case of Col. Sambo Dasuki rtd, former NSA. I cannot defend Col Sambo Dasuki, his lawyers will do that over the allegations of abuse of office and looting!*

Without prejudice to subsisting cases, however, for the Buhari administration to clamp him into detention indefinitely for about a year now, calls for serious concern. Four court orders for his release on bail, Federal Government has refused to obey, and prosecution in court is dragging! The latest decision of ECOWAS Court directing FG to release Dasuki on bail is another (Rotimi, 2016).

The extract above represents the opening paragraph of the opinion article. The author believes that the former National Security Adviser should be tried over his alleged involvement in abuse of office and looting of public funds. He however expresses concern that the case was too controversial. This is against the background that every other person accused of sharing in the money meant for the procurement of arms has been released on bail while they continue the legal battle to clear their names. The accused was granted bail by four different courts yet the government has refused to release him. This is a bad precedent for future despots. Every time, government churns out new charges and laughable excuses, keeping him in detention. No decent person will ask government to discharge and acquit a guilty offender! But the offender should not be punished until found guilty.

The extract above shows the level of confidence which the average Nigerian has in the Federal Government. Indeed, the government has given laughable excuses for the continued detention of Sambo Dasuki and the El-Zakzakys who have all been in detention since 2015.

The laughable excuses have been extended to Omoyele Sowore who was arrested in August 2019. The law says that every accused is innocent until proven guilty. Therefore, law enforcement agencies are expected to carry out thorough investigations before making arrests after which they are expected to prosecute the accused. Sadly, this is not the case in Nigeria where people are first arrested before investigations are carried out while they rot in detention. It is an injustice to punish someone that has not been found guilty.

In the Nigerian Constitution, an accused is presumed innocent until the court says otherwise. So far, Dasuki's alleged offences are allegations, which must be proved and argued in courts. The media trial of the suspect is not constitutional and we should remember that this is a democracy.

The prosecutorial foot-dragging on Dasuki's case appears suspicious and vindictive. The extract above buttresses the presumption of innocence until proven guilty in a competent court of law. The writer suggests that Dasuki's prosecutors are deliberately foot-dragging on the case in order to keep the Sokoto prince in jail for as long as possible. It is good to recall that Sambo Dasuki was allegedly a key player in the coup that ousted the then General Muhammadu Buhari in 1985. He is alleged to have carried out the arrest of the then Head of State, General Buhari. He went on to become the Aide de Camp to President Ibrahim Babangida. Political insiders and analysts suspect that President Buhari has not forgiven Sambo Dasuki for his role in the military coup ever since.

### **Conclusion**

From the critical examination of the editorial materials in the three newspapers, it is observed that the newspapers under review have not seen the need to beam their editorial light on the disobedience of court orders by the Federal Government of Nigeria. Although they have provided regular updates on the twists of each case, it would be helpful to their readers if they could give their official opinions on the issues.

By keeping mute in the face of executive disobedience of court orders, they are failing in their constitutional duty of keeping the government accountable to the people. It also amounts to failure to correlate events in the society for the benefit and understanding of the public. It must be emphasized that journalism is a profession and position of public trust, therefore, media professionals must remember that their duty to the people is greater than the fear of the ruling elite.

### **Recommendations**

In view of the analysis of the study, it is recommended that:

- i. The media should always uphold the tenets of truth as it expected of them. As members of the fourth estate of the realm, media must be neutral and be truthful in order to justify the confidence reposed in them by the people or the society.
- ii. Government must also ensure that there is a total compliance with the rule of law by ensuring separation of power among the various arms of government.
- iii. Interfering in the activities of others or usurping the power of other should be jettisoned in order to ensure equity and fairness and practice democracy the way it should be done.
- iv. That the executive should endeavour to follow judicial orders even when the decision is not in their favour. This is to ensure good, mutual relationship among the organs of government and to forestall breakdown of law and orders among the citizenry.
- v. The media should always make their positions on national issues known through their editorial contents so as to be in tandem with the agenda setting role which the media is expected to perform from time to time.

### References

- Ademilokun, M., & Taiwo, R. (2013). *Discursive strategies in newspaper campaign advertisements for Nigeria's 2011 elections*. Retrieved November 17, 2013, from Sage Publications: <http://www.sagepublications.com>
- Baran, S. J., & Davis, D. K. (2012). *mass communication theory foundations, Ferment, and Future*. Boston, MA: Wadsworth, Cengage Learning.
- Brennan, G. & Alan, H. (1994). A revisionist view of the separation of powers, *Journal of Theoretical Politics* 6: 345-68
- Daily Trust. (2019). *Sowore's revolution*. Retrieved from Media Trust Limited: <https://www.dailytrust.com.ng/sowores-revolution.html>
- Lane, D. R. (2001). *Spring 2001 theory workbook*. Retrieved January 26, 2014, from Honors: Communication Capstone: <http://www.uky.edu/>
- Littlejohn, S. W., & Foss, K. A. (2009). *Encyclopedia of communication theory*. Thousand Oaks, California: Sage Publications.
- Louw, E. P. (2005). *The media and political process*, London: Sage Publications:.
- McQuail, D. (2010). *Mcquail's mass communication theory (6<sup>th</sup> Ed)*. London: Sage Publication

Olaniyan, K. (2019). *Buhari is ignoring Nigerian judges – We must not let him get away with it.* Retrieved from Vanguard Media Limited, Nigeria: <https://www.vanguardngr.com/2019/11/buhari-is-ignoring-nigerian-judges-we-must-not-let-him-get-away-with-it/#gsc.tab=0>

Onifade, O. S. (2015). Media narratives on power relations in Nigeria: A critical Discourse analysis of three national newspaper Columnists. *Submitted to The Institute of Graduate Studies and Research in Partial Fulfilment of the Requirements for the Degree of Masters in Communication and Media Studies.* Famagusta, Gazimagusa, North Cyprus: Eastern Mediterranean University.

PM News. (2019). Sowore's wife, children protest his detention. Retrieved from Independent Communication Network Limited: [www.pmnewsnigeria.com/sowores wife.html](http://www.pmnewsnigeria.com/sowores%20wife.html)

Rotimi, K. (2016). *Dasuki's case appears suspicious and vindictive.* Retrieved from Guardian Newspapers: <https://guardian.ng/opinion/dasukis-case-appears-suspicious-and-vindictive/>

Sahara Reporters. (2019). Sowore: Save Nigeria from Further Ridicule, Falana Tells DSS. Retrieved from sahara reporters inc. [https://www.saharareporters.com/2019 Vanguard. \(2019, August 5](https://www.saharareporters.com/2019/Vanguard.%20(2019,%20August%205))

University of Twente. (2014). *Agenda Setting Theory.* Retrieved September 23, 2014, from University of Twente website: [http://www.utwente.nl/cw/theorieenoverzicht/Theory%20clusters/Mass%20Media/Agenda-Setting\\_Theory/](http://www.utwente.nl/cw/theorieenoverzicht/Theory%20clusters/Mass%20Media/Agenda-Setting_Theory/)

University of Twente. (2019). *Communication theories.* Retrieved from University of Twente: <https://www.utwente.nl/.uc/f32b97e4401021a2d8f00d5e2e5030c0add13d6eed6e400/Communication%20Theories%20University%20of%20Twente%20-%20UTwente%20-%20The%20Netherlands.pdf>