

EFFECT OF WIND SPEED VARIATIONS ON WIND GENERATOR OUTPUT IN TROPICAL CLIMATE WEATHER CONDITION

¹HAMISU USMAN, ²RAMATU ALIYU ABARSHI, & ³AMINU HAMISU KURA
^{1,2&3}*Department of Electrical & Electronics Engineering, College of Engineering,
Kaduna Polytechnic, Kaduna, Nigeria*

Abstract

Wind energy is one of the promising renewable energy sources in Distributed power Generation. But due to its inconsistency in the variation and fluctuation of the environmental wind velocity, the power generated by the wind turbine is not constant. This variation in the wind speed leads to the power quality problems in its output Voltage/Current wave forms. In this paper, the effect of wind speed variation that resulted in the instability of the wind power output in relation to the power quality is presented. However, four months wind Speed Data for a 1.5KW permanent magnet synchronous generator (PMSG) wind turbine was measured at University Putra Malaysia in order to ascertain the reliability of site for the installation of the wind turbine. The implemented model of a 1.5KW variable wind turbine (PMSG) is simulated in MATLAB/SIMULINK software environment; and the average wind speed Data is analyzed.

Keywords: Wind speed, PMSG, and Power quality.

Background to the Study

Nowadays, the interest of wind energy power generation in urban and rural areas are increasingly accepted by individuals and researchers, because of the availability of the wind velocity, which is free of charge and natural sources of energy in every environment throughout the world. The wind power generation is a clean energy, free from pollutions that reduced the global warming and carbon dioxide (CO₂) to the teeming population in the whole universe. However, due to the frequent intermittent nature of the wind speed especially in a tropical climate weather condition where the winds speed cannot be predictable. The generation of wind power becomes very difficult because of the uncertainty of the wind velocity available within the wind mills or wind blades. Moreover, due to this variation in wind speed, the generated power output produced by the wind turbine is affected, which leads to power quality problems in the output Voltage/current

wave forms by the wind turbine generator. As a result of this power quality problems manifested by the wind generator, Voltage sags, flickers, and harmonics are created within the generated power supply. Mostly, a permanent magnet synchronous generator (PMSG) is employed in the vertical axis wind turbine for power generation due to its robustness, reliability and requires no any additional DC source supply for its excitation system (Mohammed, & Nwankpa, 2000). Wind power generation predicted by European wind energy association scenario's by 2020 and 2030 will be 15.7% from 230GW and 28.5% from 400GW of the European electricity demand respectively ("Pure Power," 2011). In this paper, the effect of wind speed for a 1.5KW wind turbine system is to be studied. The wind turbine system is simulated in MATLAB. Also a wind velocity data for four months with different variation of wind speed are analysed in this paper.

Simple Model of Wind Turbine System

The process of wind turbine energy is the conversion of kinetic energy due to the wind available within the blades, and converting the kinetic energy in to mechanical energy by a prime mover, which produces a torque at its output. This kinetic energy developed by the wind turbine, its magnitude depends on the air density and the wind velocity within the vicinity of the wind blades (Babu, & Mohanty, 2010). The power generated by wind turbine is given by an expression below.

$$P_m = C_p (\lambda, \beta) \rho A \frac{1}{2} V_{wind}^3 \tag{1}$$

Where,

P_m = Output mechanical power by the wind turbine (Watts).

C_p = Performance coefficient of the wind turbine.

ρ Is the atmospheric air density within the blades in (Kg/m³).

A = is the swept area of the turbine in (m²).

V_{wind} = the tip speed ration of the rotor blade tip speed to wind speed.

β Is the blade pitch angle in (degree).

From equation (1), $C_p (\lambda, \beta)$ can be expressed by the general equation:

$$C_p (\lambda, \beta) = C_1 \left(\frac{C_2}{\lambda_i} - C_3 \beta - C_4 \right) e^{-\frac{C_5}{\lambda_i}} + C_6 \lambda \tag{2}$$

$$\text{With, } \frac{C_1}{\lambda_i} = \frac{1}{\lambda_i} + 0.08 \beta - \frac{0.035}{\beta^3 + 1} \text{ s.t. } \lambda_i = 1 / + 0.08 - 0.035 / \beta^3 + 1 \tag{3}$$

Here, the range of values of C are, $C_1 = 0.5176$, $C_2 = 116$, $C_3 = 0.4$, $C_4 = 5$, $C_5 = 21$ and $C_6 = 0.0068$.

The $C_p - \lambda$ characteristic, for different values of the pitch angle, fig 1 shows the characteristics curves of C_p against λ . For maximum values of C_p ($C_{pmax} = 0.48$) and $\beta = 0$ degree, while $\lambda = 8.1$ (Math work 2014)

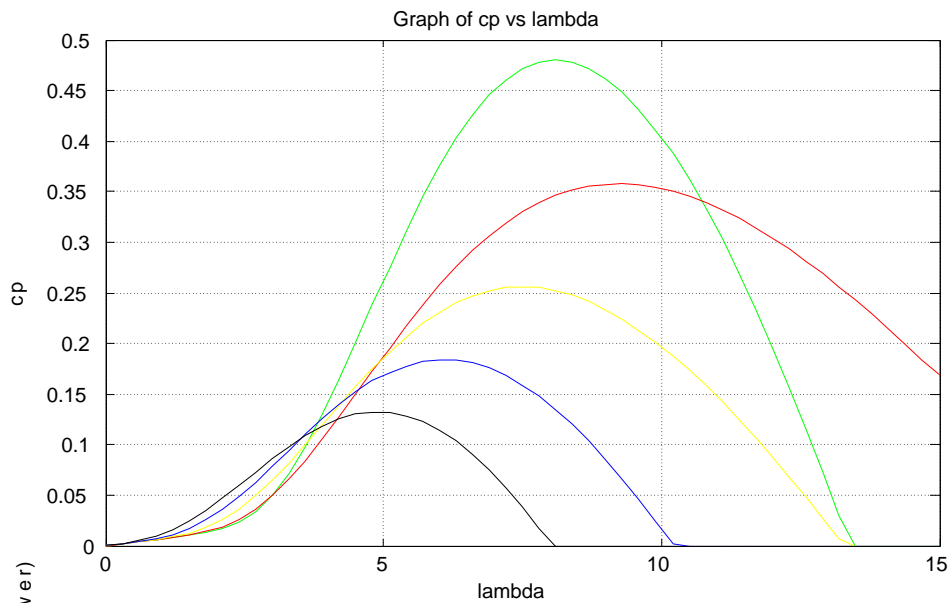
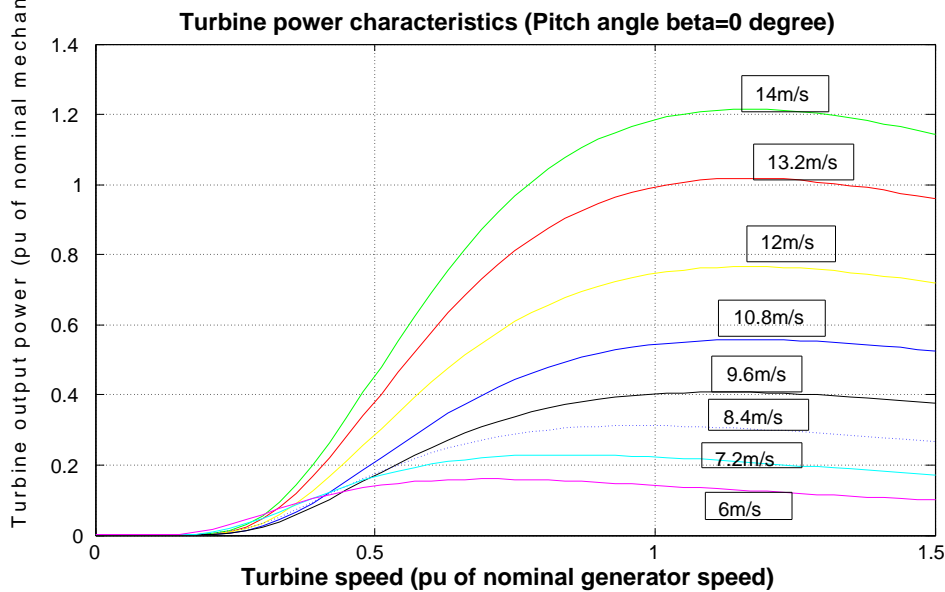

Fig 1 Performance coefficient and tip speed ratio.



Simulation Study

In this part, a permanent magnet synchronous generator of 1.5KW capacity is modelled and simulated in the famous MATLAB software environment. The behaviour of the wind turbine output voltage is obtained in figure 4, the simulation result shows the effect of the wind speed variations due to the non-availability in the wind velocity at the site of the installed 1.5KW wind turbine system. As a result of this insufficient output voltage/current wave form of the system suffered a serious distortion which resulted in the power quality

issues regarding the output voltage/current of the wind turbine. Figure 3 depicts the overall simulation of the wind turbine; a permanent magnet synchronous generator was utilized in the simulation study. The real time wind turbine at the site of the wind model with its various parameters was considered in this simulation model.

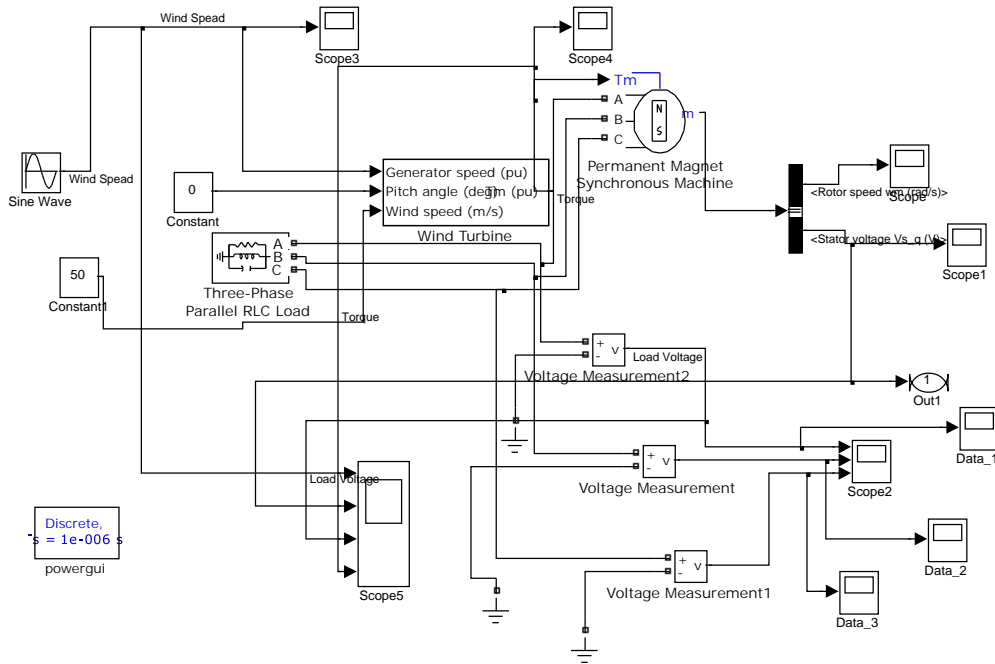

Fig 3 Overall simulation of the 1.5KW (PMSG).

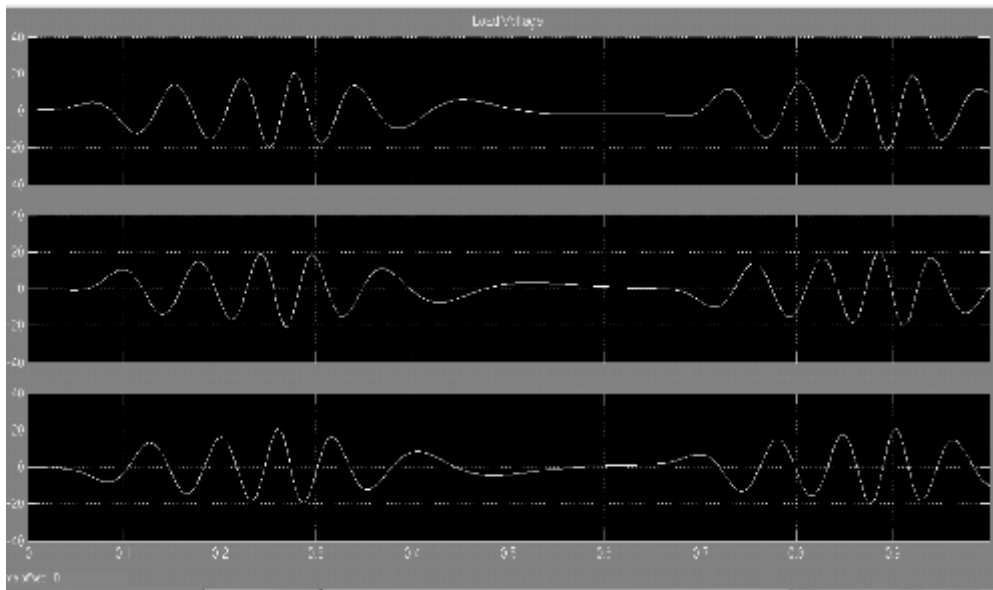

Fig 4 Load Voltages of the (PMSG) wind turbine.

Table 1. Simulation Parameters

Name	Rating	Unit
Stator phase resistance R_s	2.875	Ohms
Inductance L_d, L_q	10.5e-3, 8.5e-3	Henry
Flux linkage by magnets	0.175	Weber
Torque	1.05	NM
Inertia	0.0008	J(Kgm ²)
Frictional factor	0.001	F(NMS)
Pole pairs	4	Poles
Nominal power	1.5	KW

Average Wind Data

The wind data measured by anemometer installed for the 1.5KW wind turbine at the site in University Putra Malaysia (UPM) was measured for the months of September 2011, October 2011, November 2011 and December 2011 respectively. Table 2. Depict the corresponding average values for the months. The graph for each month is plotted in order to know the maximum and minimum values of the wind speed in order to rotate the blades for proper generation of the wind turbine. Figure 5 to 8 shows the respective graphs for each month. From the graph obtained, the minimum cut in speed of 1.5m/s for the wind velocity to rotate the blades was only attained in two places that mean the wind turbine power output is distorted to zero position due to the fluctuations of the wind velocity within the system operation see figure 4.

Power Quality Issues in Wind Turbine Power Generation

Power quality issues are one of the factors militating a constant out Voltage/Current in the generation of wind power supply. The problems of these power quality associated with this wind generation are, Voltage unbalance, flicker, harmonic, inter harmonic, as a result of poor availability of the wind velocity within the vicinity of the wind blades. However, there are other factors that caused Voltage fluctuations like, tower shadow effect, wind turbulence, wind vertical gradient and many more(Grunbaum, 2012).

Table 2. Average Wind Data

September 2011	October 2011	November 2011	December 2012
0.99913	1.270485258	1.161814875	1.58240797

Experimental Results

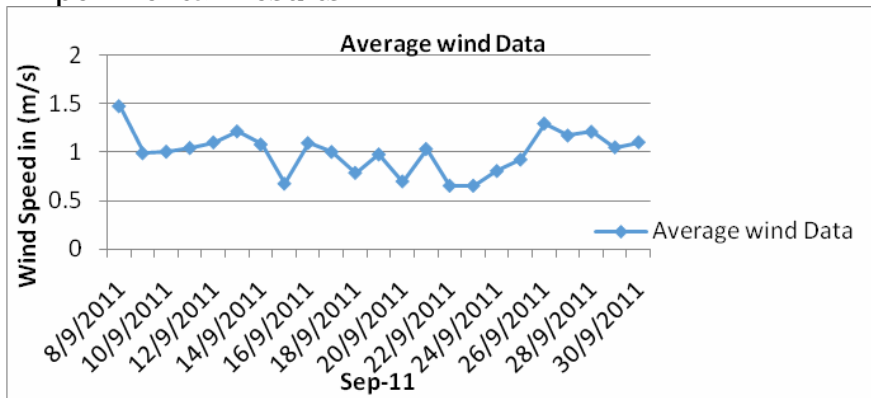

Fig 5. Average Wind Curve for the month of September 2011.

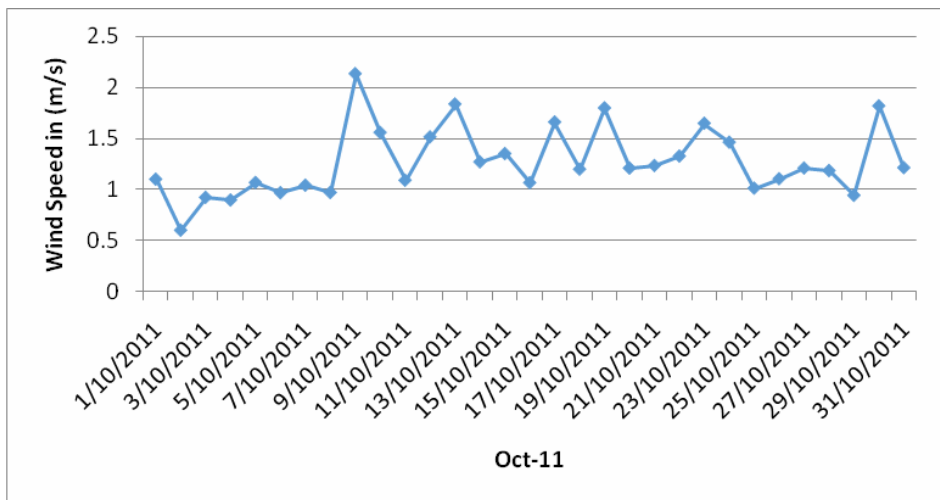

Fig 6 Average Wind curve for the month of October 2011

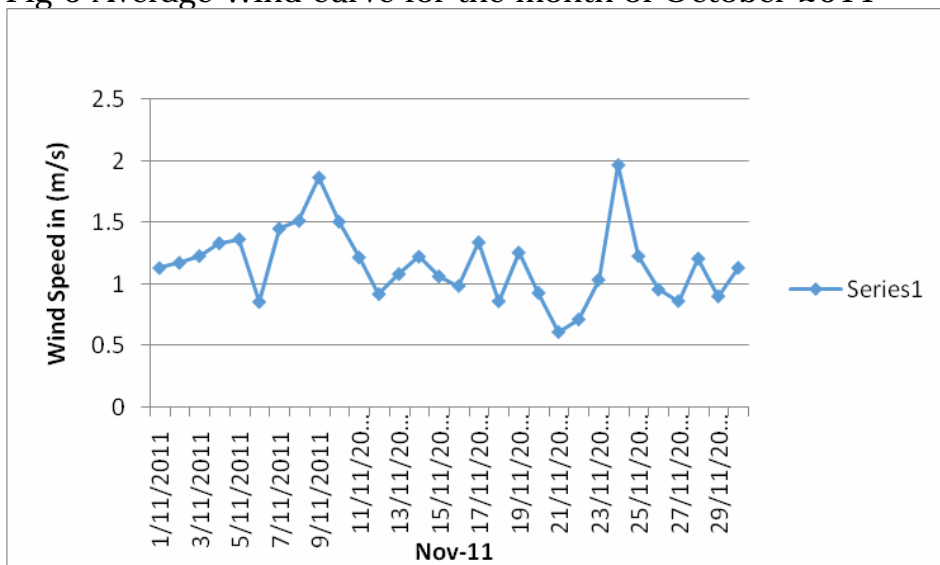

Fig 7. Average wind Curve for the month of November 2011

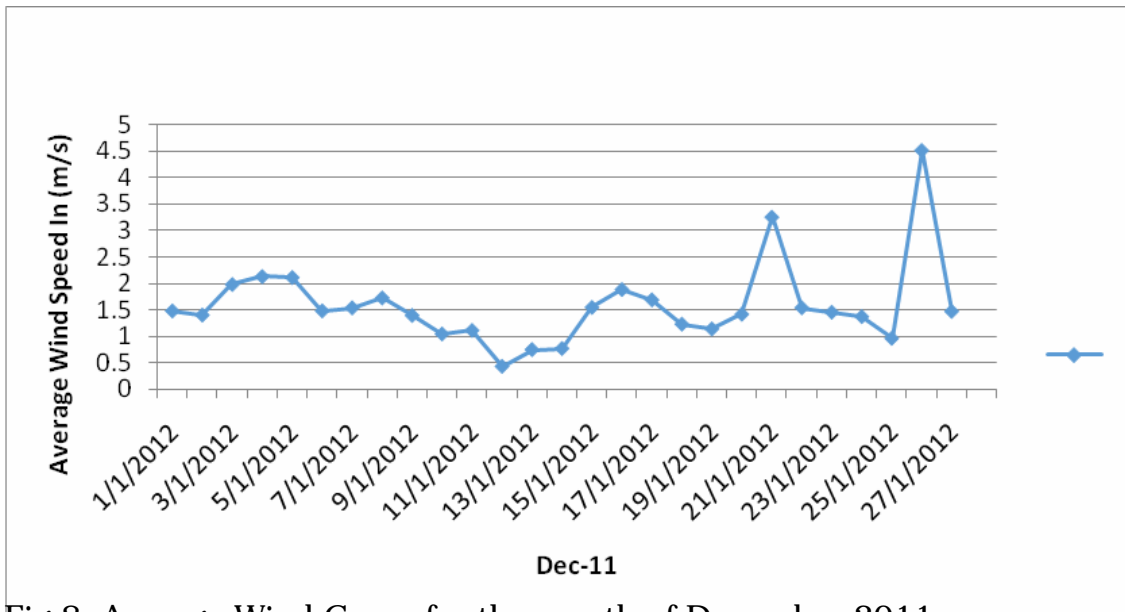

Fig 8. Average Wind Curve for the month of December 2011

Results and Discussion

Wind speed at interval of two days were monitored and recorded with called anemometer, which were installed at the site of the wind model. Results of average wind speeds of September 2011, October 2011, November 2011 and December 2011 were also captured and considered for the study respectively. The measured data of the four months were analysed using an excel software. Figures 5-8 depicts the average wind speeds plots of the four months data period. Figure 5. Wind average speed of 1.5m/S was attained, Figure 6. Wind average speed of 2.2m/S was achieved. Meanwhile, the respective wind average speed of Figure 7 and Figure 8 observed to be 2m/S and 4.5m/S. This means from the four graphs, the average wind speed were fluctuating. However, the wind blade can only rotate with minimum wind speed of 1.5m/s in order to have a continue output from the wind turbine system.

Acknowledgement

This work was duly supported by centre for advanced power engineering research, (CAPER) Department of Electrical Engineering, University Putra Malaysia. We are also grateful for providing the required materials and instruments in carrying out this research work and this support is gratefully acknowledged.

Conclusion

This paper presents the modelling and simulation of typical 1.5KW wind turbine model, bear MATLAB/SIMULINK environment. Simulation results of the proposed model were presented. Four months wind data were captured with anemometer and results of the data were analysed in excel. Results of the wind speed revealed that, the wind speed are

intermittently varied with wind speed that resulted in poor power quality of the current/voltage wave forms at the output of the wind turbine. This study proposed that, proper topographical survey of measurement has to be examined before the installation of wind model.

References

- Mohammed, H., & Nwankpa, C. O. (2011). "Stochastic Analysis & Simulation of grid Connected Wind Energy Conversion System" IEEE Transactions on Energy Conversion, Vol. 15, no. 1, pp 85-90
- Pure Power. (2011) "A Report by European Wind Energy Association" (EWEA), Wind Energy Targets for 2020 and 2030, pp 1-98
- Babu, B. C., & Mohanty, K. B. (2010) "Doubly- Fed Induction Generator for Variable Speed Wind Energy Conversion Systems Modeling & Simulation" International Journal of Computer and Electrical Engineering, Vol. 2, no. 1, pp 141-147
<http://www.mathworks.com/help/toolbox/physmod/powersys/ref/windturbine.html>
- Grunbaum, R. (2012). "Voltage and Power Quality Control in Wind Power Application by means of Dynamic Compensation" ABB Power Systems, AB, AC, power Division Vasteras Sweden, pp 1-15pendix

Appendix



Fig.1 Wind Model



Fig 2 Vertical Wind model



Fig. 2 Site Visit