



**8th Multi-Disciplinary Conference  
on African Development Analysis**  
UNIVERSITY OF NIGERIA, **NSUKKA - NIGERIA**

# CONFERENCE PROCEEDINGS

Theme: Addressing the Challenges of  
African Development Economies:  
*Multi-disciplinary Discussions*

**14TH - 15TH JUNE, 2023**





# 8TH MULTI-DISCIPLINARY CONFERENCE ON AFRICAN DEVELOPMENT ANALYSIS

---

## THEME

Addressing the Challenges of African Development Economies: Multi-disciplinary Discussions

**DATE:** Wednesday 14th - Thursday 15th June, 2023

**VENUE:** University of Nigeria, NSUKKA, Enugu - Nigeria

**TIME:** 9:00am (GMT+1)

**ISBN:** 978-051-389-3

## CONFERENCE LOC:

**Ekekwe, Ezinwanne**

Social Sciences Unit, School of General Studies

University of Nigeria, Enugu Campus

## CHAIRMAN/CHIEF HOST:

**Prof. Charles Igwe**

Vice Chancellor,

University of Nigeria

## CONFERENCE GUESTS:

**Prof. Vincent Onodugu**

Dean of Business Administration,

University of Nigeria, Enugu Campus

**Prof. Emmanuel K. Agbaeze**

HOD of Management

University of Nigeria, Enugu Campus

**Secretariat:** +2348174380445; +2348060601893

**Email:** [disciplinaryresearch@gmail.com](mailto:disciplinaryresearch@gmail.com)

**Website:** [www.internationalpolicybrief.org](http://www.internationalpolicybrief.org)

© International Institute for Policy Review and Development Strategies | June, 2023

---

All right reserved under the International Copyright Law. This Book of Abstract, its cover design and content may not be used or produced in any manner without written permission from the International Institute for Policy Review and Development Strategies | IIPRDS.



# **8TH MULTI-DISCIPLINARY CONFERENCE ON AFRICAN DEVELOPMENT ANALYSIS**

---

## **CONFERENCE PROGRAMME**

### **DAY ONE – Wednesday 14th June, 2023**

#### **OPENING SESSION/PLENARY**

Conference Registration	- 8:00am – 9:00am
Opening Prayer/Welcome Remark	- 9:00am – 9:15am
Institutional Brief/Chairman's Opening Remark	- 9:15am – 9:30am
Research Training	- 9:30am – 12noon
Launch Break/Group Photograph	- 12noon – 1:00pm
Plenary Session	- 1:00pm – 4:00pm
Policy Review Session	- 4:00pm – 5:00pm

### **DAY TWO – Thursday 15th June, 2023**

#### **OPENING SESSION/PLENARY**

Conference Registration	- 8:00am – 9:00am
Opening Prayer/Welcome Remark	- 9:00am – 9:15am
Institutional Brief/Chairman's Opening Remark	- 9:15am – 9:30am
Research Training	- 9:30am – 12noon
Launch Break/Group Photograph	- 12noon – 1:00pm
Plenary Session	- 1:00pm – 4:00pm
Policy Review Session	- 4:00pm – 5:00pm

## **Guidelines for Manuscript Submission**

### **Important Notice**

Submitting your manuscript for assessment and publication in any of the International Journal Series means that your work has not been published elsewhere in any other journal, book or in a book chapter, be it printed online (except in the form of an abstract or an academic thesis). The editor(s) of the journal(s) have the right to edit or to alter all contribution, but authors of the submitted work will receive proof before the publication of their work.

### **Submission of Manuscripts**

Manuscript should be submitted to the Editor in Chief, typed in English with Times New Roman font size 12, doubled space with 1" margin at all sides of A4 paper. Manuscripts should not exceed 14 pages. Articles for publication should be sent to the Editor, International Standard Research Publishing through the journal.

**E-mail:** [disciplinaryresearch@gmail.com](mailto:disciplinaryresearch@gmail.com)

Manuscript should be legibly written with clear symbols, drawings, photographs, chemical structures to ensure clarity and easy reproduction. Authors are urged to pay attentions to tables, figures and references which should be done in the correct format and appropriately cited in the main text.

### **Format of Paper**

The paper should include: Title, author(s) name(s) (surname in full) and address (es), an abstract not exceeding 250 words, a few key words and the main paper. The main paper should have an Introduction, Materials and Methods, Results and Discussion, Tables and Figures, Plates, Conclusion, Acknowledgment, References. If the paper has more than one author, the first on the list is the Correspondence author.

### **References**

The reference style should be APA format.

### **Review Process**

Articles for publication will be peer reviewed by 2 or 3 reviewers to ensure accuracy. Guided by the reviewer's comment on a paper, the decision of the Board is final.



### **Copyright**

Upon acceptance of a paper by the journal, the author(s) have automatically transferred copyright of the paper to International Standard Research Publishing. The transfer will ensure widest possible dissemination of information.

### **Charges**

Manuscript must be submitted along with a processing fee. Upon acceptance of a paper for publication, the corresponding author must submit the corrected paper and pay a publication fee of \$200 (USD) only. Corresponding authors shall receive one copy of Journal and could also download articles from the Journal's website.

### **Publication Ethics and Publication Malpractice Statement**

**Publication decisions:** The editor is responsible for deciding which of the articles submitted to the journal should be published. The editor may be guided by the policies of the journal's editorial board and constrained by such legal requirements as shall then be in force regarding libel, copyright infringement and plagiarism. The editor may confer with other editors or reviewers in making this decisions.

**Confidentiality:** The editor and any editorial staff must not disclose any information about a submitted manuscript to anyone than the corresponding author, reviewers, potential reviewers, other editorial advisers, and the publisher, as appropriate.

Institutional website: [www.internationalpolicybrief.org](http://www.internationalpolicybrief.org)



# CONTENTS

	<b>Paper Title/Author(s)</b>	
1	<b>Effect of Exchange Rate Fluctuations on the Balance of Payments in Nigeria (1970-2020)</b> <sup>1</sup> Adesina, O. D. & <sup>2</sup> Adewumi, A. A.	1
2	<b>Psychosocial Factors Influencing Choice of Retail Outlets Among Consumers in Ibadan</b> <sup>1</sup> Olusola Stella Akinsola & <sup>2</sup> Oluwafemi Akindele	11
3	<b>Information and Communication Technology Adoption and the Growth of Small Medium Enterprises in Lagos Metropolis, Nigeria</b> <sup>1</sup> Oyewole Kehinde Samuel & <sup>2</sup> Akindele Oluwafemi	20
4	<b>Intellectual Capital and Financial Performance of Deposit Money Banks in Nigeria</b> <sup>1</sup> Adewumi, Ademola Adeniran & <sup>2</sup> Adesina, Olufemi Dadebo	36
5	<b>Entrepreneurial Culture a Way Out of Unemployment in Nigeria (A Study of Ondo State.)</b> <sup>1</sup> Kazeem Toyin Cynthia, <sup>2</sup> Omula Godwin G. & <sup>3</sup> Adewale Adeola Oluyemisi	45
6	<b>Utilization of Learning Activity Package on Academic Achievement and Retention Among N.C.E. Biology Students in Federal College of Education Zaria, Kaduna State</b> <sup>1</sup> Shittu Adeniyi Michael, <sup>2</sup> Omoniwa Oluwatope Olubunmi & <sup>3</sup> Michael Jonathan Dadiya	63
7	<b>Assessment of Safety Attitude and Awareness in Biology Laboratory among Senior Secondary School Biology Students in Zaria Educational Zone</b> Alafiatayo, B. M., Musa, H. R. & Nuhu, B.T	71
8	<b>The Implication of Distribution Management Strategy on Customer Satisfaction (A Case Study of Transport Service Limited, Lagos State)</b> <sup>1</sup> Adewale Adeola Oluyemisi, <sup>2</sup> Kazeem Toyin Cynthia & <sup>3</sup> Omula Godwin G.	81



# CONTENTS

	<b>Paper Title/Author(s)</b>	
9	<b>Assessment of 1kVA Solar Powered Inverter for Residential Application</b> <sup>1</sup> Opeke Ebenezer & <sup>2</sup> Amudaniyu Aliyu Temitope	89
10	<b>Principles and Practice of Cooperation in the Context of Universal Application Among Cooperatives in Nigeria</b> Mudasiru Olawale Ibrahim	102
11	<b>The Significance of Accounting Records in Small Scale Businesses in Nigeria</b> <sup>1</sup> Omula Godwin G., <sup>2</sup> Kazeem Toyin Cynthia & <sup>3</sup> Adewale Adeola Oluyemisi	110
12	<b>Women Empowerment: Panacea for Poverty Reduction and Economic Development in Nigeria</b> <sup>1</sup> Omolaiye Happy Ojo & <sup>2</sup> Akindede Oluwafemi	124
13	<b>The Impact of Radio Lectures Method on Teaching and Learning of NCE II Biology Students of Federal College of Education, Zaria</b> <sup>1</sup> Dalhatu Hadiza Umar <sup>2</sup> Abubakar Salisu & <sup>3</sup> Ibrahim Muinat Mahmoud	135
14	<b>Effects of Demonstration and Practical Activities on Students' Psychomotor Performance in Learning Biology Among NCE Students in FCE, Zaria</b> <sup>1</sup> Jibril Jamila, <sup>2</sup> Muhammad Maimuna Madaki & <sup>3</sup> Ibrahim Murja Danja	144
15	<b>Conflict-Induced Theory of Hunger and Malnutrition: X-raying the Socio-Political Dimensions to Food Insecurity in Third World Countries (A Case of Nigeria)</b> <sup>1</sup> Ojiya, Emmanuel Ameh, <sup>2</sup> Agya, Atabani Adi, <sup>3</sup> Achanya, Julius John & <sup>4</sup> Nev, Stephen Aondowase	154
16	<b>Food Security: Processing, Utilization and Households' Welfare in Nigeria</b> <sup>1</sup> Ojiya, Emmanuel Ameh, <sup>2</sup> Abu Maji, <sup>3</sup> Asom, Simeon Terwuah & <sup>4</sup> Samuel, Paabu Adda	164



# CONTENTS

	<b>Paper Title/Author(s)</b>	
17	<b>Effect of Analogy Teaching Strategy on Academic Performance of NCE II Biology Students' Misconceptions of Evolution Concept in Zaria</b> <sup>1</sup> Isah Aishat Yakubu, <sup>2</sup> Olaitan Aishat Salau & <sup>3</sup> Muhammad Ismail	180
18	<b>Problematizing Statement of Research Problem in a Research Topic</b> <sup>1</sup> Awen, Benjamin Iorsue and <sup>2</sup> Jimoh, Ihiovi Ojo	189
19	<b>Socioeconomic Determinant of Under Five Malnutrition in Nigeria</b> <sup>1</sup> Emeka Eze, <sup>2</sup> Obinna Osuji & <sup>3</sup> Justin Alugbuo	197
20	<b>Impact of Project Based Strategy on Students Retention and Performance in Biology Concept for Entrepreneurial Skills Acquisition among Secondary School in Zaria, Kaduna State</b> Ezeaghasi, Ngozi Eucharia	208
21	<b>Factors Mitigating Against Women Participation in Computer Science in Borno State</b> <sup>1</sup> Ojo Oluwasesan Adebusuyi, <sup>2</sup> Abdullahi Abdulfatai Oluwashina, <sup>3</sup> Aji abdulmumini & <sup>4</sup> Itodo Andrew	224
22	<b>Effect of Deferred Tax Accounting on Financial Performance of Manufacturing Companies in Nigeria</b> Okafor Victor Ikechukwu	231
23	<b>A Contrastive Study of Lexical Field of Foods in English and Jukun (WĀPĀN) Languages</b> <sup>1</sup> Ajiduku, Beavens Ahmadu & <sup>2</sup> Ishaya, Yusuf Tsojon	243
24	<b>The Mobility of Adjuncts in Jukun Clause</b> <sup>1</sup> Alli, Apaji Jones & <sup>2</sup> Ishaya, Yusuf Tsojon	254
25	<b>Impact of Capital Flight on Domestic Investment in Nigeria</b> <sup>1</sup> Ishaku Rimamtaanung Nyiputen <sup>2</sup> Okoh Abo Sunday <sup>3</sup> Yakubu Maigaji Ibrahim <sup>4</sup> Uwaeke, George Uchechukwu & <sup>5</sup> Enyikah Illiya	262
26	<b>Advancements in Intelligent Nodes: Enabling Efficiency and Connectivity on the Internet of Things (IOT) Era</b> <sup>1</sup> Siman Emmanuel <sup>2</sup> Oladunjoye John Abiodun, <sup>3</sup> Okwori Okpe Anthony & <sup>4</sup> Samuel Amachundi Adda	285



# CONTENTS

	<b>Paper Title/Author(s)</b>	
27	<b>Analysis of the Syntactic Structure and Communicative Acts in Selected Online Covid-19 Communication Campaign Posters</b> <sup>1</sup> Ishaya Yusuf Tsojon & <sup>2</sup> Abigail Best Emmanuel	299
28	<b>Prevalence of Peptic Ulcer among Youths in Wukari, Taraba State, Nigeria</b> <sup>1</sup> Imo Chinedu, <sup>2</sup> Asuelimen Steve Osagie, <sup>3</sup> Ale Ebenezer Morayo, <sup>4</sup> Abah Moses Adondua <sup>5</sup> Gambo Asabe Mary & <sup>6</sup> Ikwebe Joseph	315
29	<b>Impact of Climate Change on Food Security in Nigeria</b> <sup>1</sup> Ishaku, Rimamtanung Nyiputen <sup>2</sup> Abu Maji <sup>3</sup> Okoh Abo Sunday <sup>4</sup> Uwaeke, George Uchechukwu & <sup>5</sup> Yakubu Maigaji Ibrahim	322
30	<b>Awareness of Hypertension and Hypotension among Youths in Wukari Metropolis, Nigeria</b> <sup>1</sup> Imo Chinedu, <sup>2</sup> Abah Moses Adondua, <sup>3</sup> Asuelimen Steve Osagie, <sup>4</sup> Ale Ebenezer Morayo <sup>5</sup> Mohammed Maryam & <sup>6</sup> Ikwebe Joseph	334
31	<b>Effect on Strength of Concrete made with Partial Replacement of Sand with Marble Dust</b> <sup>1</sup> Akinwunmi, Ayoola & <sup>2</sup> Isah, Jimoh Karikati	341
32	<b>The Effectiveness of Inventory Management and Profitability of Manufacturing Firms</b> <sup>1</sup> George Charisma (PhD) & <sup>2</sup> Igho Enamejewan Gift	351
33	<b>Harnessing the Significance of Effective Tax Administration for Tax Income and Economic Growth in Benue State</b> <sup>1</sup> Osayi, Valentine Igbinedion, & <sup>2</sup> Akemieyefa Matthew	361
34	<b>Space and Spatiality as Semiotic Tools for Building an Admirable Community</b> Samaila Yakubu	375
35	<b>The Impacts of Women Association in Providing Sanitation Facilities on Community Development in Cross River State</b> <sup>1</sup> Bassey Ekpenyong Anam, <sup>2</sup> Virginia Emmanuel Ironbar, <sup>3</sup> Otu Offiong Duke & <sup>4</sup> Esther Esien-Cobham Uzoh	384
36	<b>Swem As An Agent Of Justice In Tiv Philosophy</b> <sup>1</sup> Tughhemba Terfa Nicholas & <sup>2</sup> Ogaba, Solomon Isenyo	398





***Book of  
Proceedings***





## Effect of Exchange Rate Fluctuations on the Balance of Payments in Nigeria (1970-2020)

<sup>1</sup>Adesina, O. D. & <sup>2</sup>Adewumi, A. A.

<sup>1&2</sup>Department of Accountancy, School of Business and Management Studies,  
Federal Polytechnic, Ile-Oluji, Ondo State.

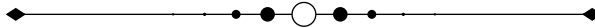

### **Abstract**

**T**his study examined the effect of exchange rate fluctuation on Nigeria's balance of payments over a 50-year period, from 1970 to 2020. Secondary data from the Central Bank of Nigeria (CBN) Statistical Bulletins and the National Bureau of Statistics were used in the study. Other variables provided as control variables include statistics on imports and exports for the same time period. Statistical studies were used to perform normality tests, unit root tests using Dickey-Fuller (DF) for data set stationarity, and cointegration tests using Johansen cointegration test for long run association between variables. The Granger causality test was also performed. The data were estimated using the Vector Error Correction Mechanism (VECM). The Granger Causality test results show that the balance of payments granger caused import, however there is no causality relationship between the exchange rate and the balance of payments in Nigeria. According to the Vector Error Correction Mechanism (VECM) estimations, the exchange rate has a positive but minor effect on Nigeria's balance of payment. Based on this outcome, the government should direct its monetary and fiscal instruments towards increasing national productivity and supporting exports, which will go a long way towards stabilising the currency rate and maintaining a favourable balance of payments.

**Keywords:** Exchange rate, Balance of payments, Imports, Exports, Vector-error correction mechanism

---



## **Introduction**

A country's balance of payments is a systematic account of its economic interactions with the outside world in a fiscal year, usually one year. A country's balance of payments reveals its foreign financial transactions and economic performance. The price exchange rate, GDP, inflation, interest rate, and others affect a country's balance of payments. Exchange rates are important in international relations because they link countries' monetary units, enabling trade. Oladipupo and Ogbenovo (2011). Exchange rate variations effect the balance of payments, export and import competitiveness, and capital flows. Depreciating the local currency can boost export revenues and trade balance. However, rising import costs may worsen the trade balance. Exchange rate changes effect capital flows and the balance of payments' financial account. Before deregulation and the Structural Adjustment Programme (SAP), Nigeria's exchange rate policy looked to favour naira-overvaluation. The 1981 exchange rate was 0.90 cents to N1. This supported importing and discouraged non-oil export, making the Nigerian economy over-dependent on imports. Given this situation, imports surpassed exports, resulting in a deficit and a depreciated currency. Exchange rate policy prioritises balance of payments maintenance since underperformance can threaten a country's reserves and economic development. Shafi, Hua, Idrees, and Nazeer (2015) noted that a country's external performance is heavily influenced by its balance of payments, which affects its strengths and trading position.

From the Second-tier foreign currency Market (SFEM) to the fully liberalised Foreign Exchange Market (FEM), Nigeria has employed a variety of institutional frameworks and management tactics to achieve currency rate stability and policy since 1986. Changes in policy were implemented because of fluctuations in the currency rate. The acronyms AFEM, IFEM, DAS, WDAS, and RDAS stand for the Autonomous Foreign Exchange Market, the Interbank Foreign Exchange Market, the Dutch Auction System, and the Retail Dutch Auction System, respectively. It is now 2019 (Yakubu et al.). Nigeria's balance of payments has suffered from huge exchange rate fluctuations despite government policy. Policymakers in the country have struggled to maintain a stable currency rate that will improve the balance of payments and support economic growth and development (Onoh, 2002; Nnanna, 2004; Ogbonna, 2010). Imports usually outnumber exports in Nigeria, which is unhealthy for the economy. Naira devaluation was thought to ease balance of payment pressures. The Naira was devalued, ironically because Nigeria's foreign trade system did not meet balance of payment policy requirements. Therefore, an empirical analysis of exchange rate devaluation's impact on the balance of payments from 1970 to 2020 is necessary.

## **Literature Review**

### **Conceptual Review**

#### **Balance of Payment**

The IMF defines the BOP as "a statistical statement that summarises transactions between domestic economic units and international economic units over a specified time period." The BOP consists of two main components: the current account and the capital and financial account. The current account captures international transactions involving the exchange of goods, services, income (such as wages and dividends), and unilateral transfers (such as foreign aid and remittances). It reflects a country's net exports or imports of goods and services and represents the economic relationship between a country and its trading partners. The capital and financial account records cross-border capital flows, including foreign direct

investment (FDI), portfolio investment, loans, and changes in reserve assets. It shows how a country's assets and liabilities change due to international financial activities and reflects the financial relationship between a country and the rest of the world.

### **Exchange Rate**

Exchange rate is the exchange rate between currencies. The Bank for International Settlements (BIS) defines "exchange rate" as "the price of one currency expressed in terms of another" (BIS 2016). Supply and demand, interest rates, inflation, economic indices, and market speculation affect it. Exchange rates affect global trade, investment, and finance. Market forces set the exchange rate in a floating exchange rate system. Foreign exchange market supply and demand affect currency value. A currency appreciates when demand rises. If demand drops, value depreciates. A fixed exchange rate system pegs a currency to another currency, a basket of currencies, or a commodity. Central banks purchase and sell their own currency in the foreign exchange market to maintain the exchange rate.

### **Export**

Exporting involves selling and shipping goods and services from one country to another. It is crucial to international trade and nation-building. According to the WTO, "exports are the goods and services produced in one country and purchased by residents of another country". Exports generate cash, create jobs, promote domestic industries, and strengthen international connections. Exported goods can include a wide range of products, such as manufactured goods, agricultural produce, raw materials, technology, and services like tourism, consulting, or software development. Countries engage in exports to take advantage of their comparative advantages, such as lower production costs, access to unique resources, specialized skills, or superior product quality. Exporting allows businesses to expand their market reach beyond domestic boundaries and tap into the demand and opportunities available in foreign markets. Overall, exports play a crucial role in fostering economic growth, job creation, and global economic integration, making them a vital component of a country's trade strategy.

### **Import**

Import refers to the act of purchasing and bringing goods or services produced in one country into another country for domestic use or resale. According to the World Trade Organization (WTO), "imports are the goods and services purchased by residents of a country from foreign sellers" (WTO,). It is an integral part of international trade and allows countries to access products and resources that may not be available domestically. Imports contribute to a country's economy by satisfying domestic demand for goods and services that cannot be adequately produced or are more expensive to produce locally. They provide consumers and businesses with a wider range of choices, promote competition, and can support domestic industries by providing necessary inputs or components for production. Imported goods can include various products, such as raw materials, machinery, consumer goods, energy resources, and specialized products that are not produced domestically. Services like transportation, tourism, telecommunications, and consulting can also be imported. Countries engage in imports to meet domestic demand, supplement inadequate domestic production, access specialized products or resources, or take advantage of cost or quality advantages in foreign markets. Importing allows businesses and consumers to access a diverse range of products and technologies from around the world.

## **Theoretical Review**

### **The Balance of Payments (BOP) Theory**

Based on the BOP current account's credit and debit balances, this theory analyzes how exchange rates are set. A currency's effective supply can be thought of as the sum of its credit balances and its debit balances the real demand. According to the balance of payments theory, the exchange rate of a currency with freely floating exchange rates is determined. The value of a country's currency rises as its balance of payments improves and falls when it worsens. According to this hypothesis, the supply and demand for foreign currency establish the exchange rate. Disequilibrium at the BOP is indicated by the difference in magnitudes. When the latter is larger than the former, we have a BOP deficit due to an excess demand for foreign exchange. According to this school of thought, the foreign exchange market is as impersonal as any other market, and the exchange rate, as the domestic currency price of foreign currency, may be established in the same manner as any other price. Therefore, it implies a freely variable exchange rate.

### **Empirical Review**

Scholars have examined how exchange rate volatility affects trade flows, foreign direct investment, and overall macroeconomic stability. Studies conducted in various countries have produced mixed results, indicating that the impact of exchange rate fluctuations on the balance of payments can vary depending on specific economic conditions and policy responses. In a study comparing the economies of India and Pakistan, Shafi et al. (2015) looked at the factors that affect trade by analyzing import, export, industrial growth, consumption level, and oil prices exchange rate changes. For the past 31 years, data on specific factors has been collected annually from India and Pakistan. Cointegration testing suggests a long-term connection between the two economies. The short-term dynamic between India and Pakistan has been signed off on in a major way and is correct, but other variables have not. Does Granger causality hold for Pakistan's exchange rate in terms of the balance of payment? The Indian trade surplus or deficit has nothing to do with the country's exchange rate. The conclusion is that the exchange rate is crucial in a free market economy. Every economy, developed or emerging, is vulnerable to the swings in the foreign exchange market. Countries' currency rates depreciate and appreciate as a result of the market dynamics of supply and demand.

Exchange rates' impact on Nigeria's BOP was empirically studied by Echekoba (2016), who looked at data from 1990 to 2013. The study makes use of the unit-root test, the cointegration method, and multiple regression analysis as econometrics tools. The study's most important finding was that the exchange rate greatly affects the trade surplus or deficit. Dayo and Akindele (2016) investigated the effect of the exchange rate on Nigeria's total BOP, capital account, and current account balance. Model estimation was performed using the Autoregressive Distributed Lag (ARDL) method of cointegration. The short-run error correction model then came into play. Results show that an increase in the value of the currency over another had a negative impact on both the BOP and the current account balance. Two-stage least squares statistical analysis was used in Mbanasor and Obioma's (2017) study on the effect of changes in the exchange rate on Nigeria's balance of payment. The study's main findings suggested that such changes had a positive and negligible effect on Nigeria's balance of payment. The relationship between Nigeria's trade balance (TB) and the country's real effective exchange rate (REER) was studied by Onakoya et al. (2018), who used the term "J-curve" to describe the phenomenon. Following the results of an initial Augmented

Dickey- Fuller (ADF) test for stationarity of the model's data series from 1981 to 2016, the authors decided to use Johansen Cointegration. In addition, tests for Granger causality and Impulse Response Function were used. Normality, heteroskedasticity, and autocorrelation tests were performed as part of the post-estimation diagnostic validation. This study provided empirical evidence that a devaluation of the Naira has no long-term negative effects on the trade balance. Longitudinal analysis of the connection between TB and REER and GDP yielded null results.

Foreign reserves responsiveness to exchange rate variables was investigated by Ebere et al. (2018) with a focus on the Nigerian economy. The foreign exchange reserve variable served as the dependent variable, while all other factors associated with the exchange rate served as the independent variables. We used time series data from 1996-2016. The Auto Regressive Distributed Lag (ARDL) Model was used in conjunction with a correlation matrix. Nominal exchange rate has a positive but insignificant link with foreign reserves, but the real exchange rate has a positive and large association. This argues for a deliberate course of action to ensure that the Nigerian economy's exchange rate is managed in the most efficient and beneficial way possible. The findings have implications for generalizations and policy directions concerning the management of foreign reserve and its interplay with currency rate and associated issues in economies like Nigeria. Using monthly data from 1997 to 2016, Yakub et al. (2019) looked into how fluctuations in the Nigerian currency's value affected the country's trading patterns. The nominal exchange rate volatility series was generated using a GARCH model. The ARDL limits testing method was used to identify the interdependent relationships between variables. The direction of causality among the variables was also determined using the Granger causality test. The study concluded that exchange rate volatility has a detrimental effect on Nigeria's trade flows in the short term but has no such effect in the long run. Kanu and Nwadiubu (2020) examined Nigerian foreign trade and exchange rate volatility. The study used 1996–2018 secondary data. Throughout the ten periods, Impulse response analysis showed a negative relationship between exports and real effective exchange rate, whereas imports were mostly positive. Imports cause exports, while exports do not cause imports. ARCH modelling reveals a first-order Arch influence and a large GARCH term. GARCH's negative mean term coefficient produced a singular covariance that is not unique. Results reveal REER clustering volatility on Nigerian import-export trading. This could hurt Nigeria's growth by reducing exports and foreign exchange earnings for development. Imports falling could also affect domestic output and consumption. It could hurt Nigeria's balance of payments. Since financial shocks increase exchange rate volatility, monetary and fiscal policies are needed to minimise the impacts.

### **Methodology**

This study employs a quantitative approach to analyze the effect of exchange rate fluctuations on the balance of payments in Nigeria. Historical data on exchange rates, export, and import variables were collected from reputable sources, such as the Central Bank of Nigeria, the National Bureau of Statistics, and international databases. Statistical analyses were employed to carry out normality test, unit root test using Dickey-Fuller (DF) for the stationarity of the data set, also cointegration test was conducted using Johansen cointegration test for long run relationship among the variables. Granger causality test was also conducted. The data were estimated using Vector Error Correction Mechanism (VECM).

**Model Specification**

$Lny = (X1, X2 \& X3)$

Where

Lny = log of Balance of Payments

X1 = Export earnings

X2 = Import

X3 = Exchange rate

The above function specifies exponential relationship between y (dependent variable) and x (independent variables). This function can further be written as:

$Y = f [ e (b_0 + b_1 x_1 + b_2 x_2 + b_3 x_3$

**Results and Discussion**

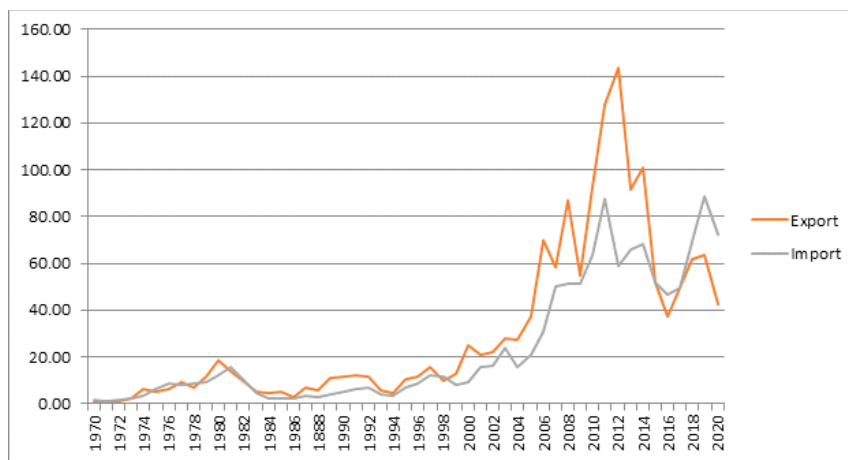

Figure 1: A times series chart illustrating Import and Export in Billion Dollars from 1970 - 2020. The chart illustrates the times series data on import and export in billions of dollars from 1970 to 2020.

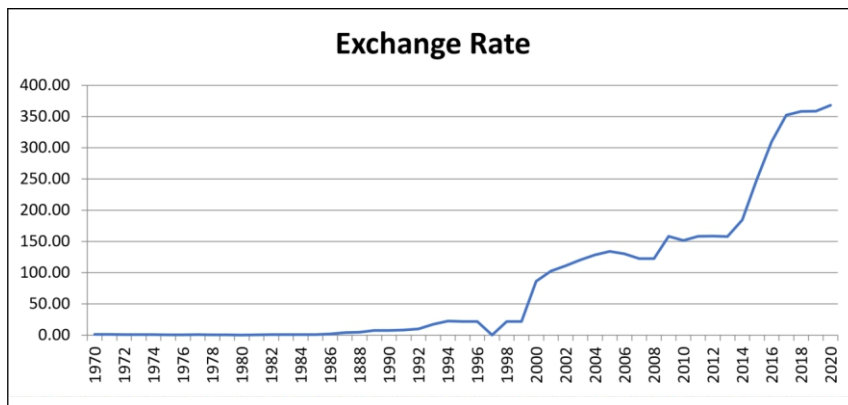

Figure 2: A times series chart illustrating Exchange Rates in Billion Dollars from 1970 - 2020. The chart illustrates the times series data on Nigeria exchange rate as \$1 to naira.



**Unit Root Test : Table 1**

Variable	ADF STAT	CRITICAL VALUE	ORDER
Balance on Payment	-6.9107	-3.5063	I(1)
Import	-2.6688	-3.5266	I(1)
Export	-7.6899	-3.5043	I(1)
Exchange Rate	-11.1411	-3.5950	I(1)

Source: EViews Output

To find out if the data were steady, an ADF unit root test was performed. All four variables (Balance on payment, Import, Export, and Exchange rates) pass the unit-root test, indicating they are stationary at the initial difference (I (1)). This means that until first-order differences are made, all four variables (Balance on payment, Import, Export, and Exchange rates) are unit-root. The correlogram analysis only added more weight to this.

**Table 2: Block-Wald Causality Test**

Dependent Variable: D(Balance of payment)			
Excluded	Chi-sq	Df	P-value
D(Import)	2.5116	2	0.2848
D(Export)	6.8848	2	0.0320
D(Exchange Rate)	2.1087	2	0.3484

Source: Eviews Output

Table 2 shows the exchange rate Chi-Square probability was  $0.3484 > 0.05$ . The exchange rate (EXR) does not impact the balance of payments. Since its Chi-Square probability was  $0.2848 > 0.05$ , import does not causally affect the balance of payments. Export's Chi-Square probability was  $0.0320$ . Export causes the balance of payments.

**Table 3: Test for Vector Error Correction:**

<b>Balance of payment (-1)</b>	1			
<b>Import (-1)</b>	-260715761.5479892			
	289381922.4572351			
	[-0.90094]			
<b>Export (-1)</b>	49816715.22771935			
	132637365.6181502			
	[0.37559]			
<b>Exchange Rate (-1)</b>	59085789.7116693			
	40046285.87439528			
	[1.47544]			
<b>C</b>	-5470562179.522129			
<b>Error Correction</b>	D (Balance of payment)	D(Import)	D(Export)	D (Exchange Rate)
<b>CoinEq1</b>	<b>0.2621</b>	<b>5.0227</b>	<b>1.8426</b>	<b>4.2170</b>
	(0.1268)	(1.2332)	(2.4306)	(1.7512)
	[-2.0670]	[4.0730]	[0.7581]	[2.0810]
<b>D (Balance (-1))</b>	0.6146	-6.1011	4.0180	-4.9482
	(0.2529)	(2.4598)	(4.8483)	(3.4931)
	[2.4296]	[-2.4804]	[0.8288]	[-1.7519]
<b>D (Balance (-2))</b>	-0.2506	-9.8903	-6.4142	-4.6643
	(0.1928)	(1.8749)	(3.6954)	(2.6625)
	[ 1.3000]	[-0.5275]	[-1.7357]	[-1.7519]

<b>D (Import (-1))</b>	8968057.2246 (184885606.40) [0.04851]	-0.60296 (0.17978) [-3.3543]	0.887325 (0.35435) [2.5041]	0.08074676 (0.2553) [0.3163]
<b>D (Import (-2))</b>	358699500.16 (279854494.39) [ 1.28174]	--0.79556 (0.2721) [-2.9235]	-1.0636 (0.5364) [-1.9830]	0.41119 (0.3864) [ 1.06405]
<b>D (Export (-1))</b>	-134659858.94 (132616327.43) [-1.01541]	0.2908 (0.1290) [ 2.2553]	-0.0310 (0.2542) [-0.1218]	-0.3397 (0.1831) [-1.8550]
<b>D (Export (-2))</b>	117889752.77 (91606899.47) [ 1.28691]	0.1005 (0.0891) [ 1.1279]	0.3394 (0.1756) [ 1.9331]	-0.5396 (0.1265) [-4.26571]
<b>D (Exchange (-1))</b>	85830446.59 (76316232.60) [ 1.12467]	-0.1520 (0.0742) [-2.0479]	-0.05555 (0.1463) [-0.3798]	0.3600 (0.1054) [ 3.41185]
<b>D (Exchange (-2))</b>	22244816.41 (72711483.33) [ 0.30593]	0.2278 (0.0707) [ 3.2218]	0.1154 (0.1394) [ 0.8280]	-0.0975 (0.1004) [-0.9709]
<b>C</b>	-1620391477.49 (1320312320.03) [-1.22728]	2.5151 (1.2839) [ 1.9590]	-0.3114 (2.5305) [-0.1231]	5.0612 (1.8232) [ 2.77604]
<b>R-squared</b>	0.4344	0.5854	0.5339	0.7109
<b>Adj. R-squared</b>	0.2847	0.4757	0.4106	0.6344
<b>Sum sq. resids</b>	1.5E+21	1500.08	5827.65	3025.12
<b>S.E. equation</b>	6830906163.11	6.6423	13.0920	9.4326
<b>F-statistic</b>	2.9012	5.3351	4.3279	9.2900

Source: E-Views Output

Table 3 shows vector error correcting technique output. From the table, the error correction term (Cointeq1) returned -0.2621 at 5% significance. This long-run coefficient exhibits causality from import, export, exchange rate, and balance of payment. Desirable negative values demonstrate its ability to recover from deviations. Differentiated term coefficients capture short-term impacts. That's the influence, while the VECM variable's coefficient shows whether past values affect current values. The magnitude and statistical significance of the error correction term coefficient indicate the propensity of each variable to return to equilibrium. A significant coefficient means past equilibrium errors affect current outcomes in the long run. The short-run coefficients of the lag one of the balance of payments yielded a positive significant value, implying that a percentage increase will lead to a percentage increase in current BOP by 0.6146, and a negative insignificant value of the lag 2 with a t-value of -1.3000 indicates a percentage decrease of 0.2506.

According to the short-run coefficients of the exchange rate (IMP), a percentage increase in its first and second lag will raise the balance of payments (BOP) by 8968057.2246 with t-value 0.04851 and 358699500.16 with 1.28174. The t-values are not significant. The short-run coefficients of lag one of exports yielded a negative insignificant value, implying that a percentage decrease in exports will decrease current BOP by -1346598.5894 with t-value of -1.01541. The value of lag two is positive by 117889752.77 with insignificant t-value of 1.28681, indicating an increase in current BOP.

The short-run coefficients of EXCH indicate that increasing lag one and lag two will raise

BOP by 858304616.59 with a t-value of 1.2467 and 222244816.41 with a t-value of 0.30593. This is expected since a higher exchange rate makes our exports more competitive and boosts the balance of payments. R-squared was 0.4344, below 60%. The independent variables have limited explanatory power. The dependent variable is explained by the independent variable by 43.44%. F-statistics determine the regression plane's statistical significance. Regression shows the F-statistics probability value was 2.9012. The entire regression plane is statistically significant. Import, export, and exchange rate also affect the balance of payments.

### **Conclusion and Recommendations**

Using Nigerian data, this study examines the relationship between balance of payment, import, export, and exchange rate devaluation. Theoretical aspects were assessed to better comprehend this link. Through an in-depth analysis of exchange rate, import, export, and balance of payment theory. The balance of payment model used Vector Error Correction Mechanism (VECM) and Block-Wald Causality Test to determine if the four variables were statistically related. Exchange rate depreciation positively and statistically insignificantly affects balance of payment. Import in lag one and two positively and statistically insignificantly affect balance of payments. Export has insignificant negative and positive effects in lags one and two. Since exchange rate, import, and export have statistically minor effects on balance of payments, we accept the hypothesis that there is no meaningful relationship between them in Nigeria.

### **Recommendations**

Recommendations based on this research:

- i. To maintain a strong Naira, the Nigerian government should use its monetary and fiscal tools to stimulate exports. Stabilising the currency rate and maintaining a positive balance of payments will benefit from this.
- ii. Nigeria should limit openness to prevent it from becoming a dumping ground, which will cut imports and boost exports. They shouldn't import too much, especially from developed countries. Tariffs, quotas, etc. can limit imports.
- iii. A stable economy attracts Foreign Direct Investment. If the economy is unstable, investors will be wary. Thus, the government must provide economic stability. It increases balance of payment by encouraging investment.

### **References**

- Bank for International Settlements (BIS). (2016). BIS Working Papers No. 570: The currency composition of international reserves, trade invoicing and exchange rate pass-through. Retrieved from <https://www.bis.org/publ/work570.pdf>
- CBN (2017). Central Bank of Nigeria Annual Reports and Statement of Account, CBN Abuja, Nigeria.
- Dayo, W. & Akindele, K.O (2016). The effects of exchange rate policy on Nigeria's agricultural competitiveness. African Economic Research Consortium AERC/CKEA Nairobi, Research paper 42, 52.



- Ebere, U. K., Ogochukwu, E. U., Ndubuaka, V. C. & Ozioma, P. I. (2019). Exchange rate and foreign reserves interface: Empirical evidence from Nigeria. *The Economics and Finance Letters*, 6(1), 1-8.
- Echekoba, D. D. (2016). The impact of exchange rate volatility on South African exports. *Mediterranean Journal of Social Sciences*, 4(2), 507-513.
- International Monetary Fund (IMF). (2007). Balance of payments manual, Sixth Edition. Washington, D.C.: International Monetary Fund.
- Kano, S. I. & Nwadiabu, A. (2020). Exchange rate volatility and international trade in Nigeria. *International Journal of Management Science and Business Administration*, 6(5) 56-72.
- Mbanasor, V. & Obioma, O. P. (2017). Exchange rate volatility and non-oil exports in Nigeria: 1986-2008. *International Business and Management*, 9(3), 70-79.
- Nnanna, O. (2004). Foreign private investment in Nigeria. *Economic and Financial Review*, 41(4), 87-95.
- Ogbonna, B. C. (2010). Financial development, trade openness and economic growth in a small open economy: Evidence from Botswana. *Journal of Banking*, 4(1), 59-76.
- Oladipupo, A. O. & Ogebenovo, F. O. (2011). Impact of exchange rate on the balance of payment in Nigeria. *An International Multidisciplinary Journal*, 5(4), 73-88.
- Onakoya, A. B. & Johnson, S. B. (2018). Exchange rate and trade balance. The Case of J-Curve effect in Nigeria. *KIU Journal of Social Sciences*, Kampala International University. 4(1), 47-63.
- Onoh, J. K. (2002). Dynamics of money, banking and finance in Nigeria. An Emerging Market, Aba: Astra Meridian.
- Shafi, K.; Hua, L.; Idrees, I. & Nazeer, A. (2015). Impact of the exchange rate, inflation rate and interest rate on the balance of payment: A study from India and Pakistan. *American Journal of Business, Economics and Management*, 3(1), 9-13.
- Shari, K.; Hua, L.; Idrees, I. & Nazeer, A. (2015). Impact of the exchange rate, inflation rate and interest rate on the balance of payment: A study from India and Pakistan. *American Journal of Business, Economics and Management*, 3(1), 9-13.
- World Trade Organization (WTO). (n.d.). Glossary: Exports. Retrieved from [https://www.wto.org/english/thewto\\_e/glossary\\_e/glossary\\_e.htm#E](https://www.wto.org/english/thewto_e/glossary_e/glossary_e.htm#E)
- Yakub, M. U., Sani, Z., Obiezue, T. O. & Aliyu V. O. (2019). Empirical investigation on exchange rate volatility and trade flows in Nigeria. Central Bank of Nigeria. *Economic and Financial Review*, 57(1) 23-46.



## Psychosocial Factors Influencing Choice of Retail Outlets Among Consumers in Ibadan

Olusola Stella Akinsola & Oluwafemi Akindele  
Department of General Studies  
Federal Polytechnic, Ile-Oluji, Ondo State

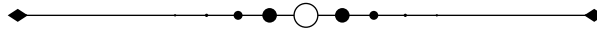

### Abstract

**T**he world of food distribution is experiencing globalization that is encouraging the development of various supermarkets in Ibadan. Consumers, therefore, have to decide on where to buy between the old traditional markets and new supermarkets. Previous studies focused on a clean environment, price, parking, product variety, proximity and bargaining as factors that influence the choice of retail outlet. This study was therefore designed to investigate the influence of personality (extraversion and openness to experience) and socio-demographic factors (gender and income) on the choice of retail outlet among consumers in Ibadan, Oyo State. The purposive sampling technique was used to select 336 Ibadan residents through a structured questionnaire that measured socio-demographic variables, personality ( $\alpha=0.71$ ) and choice of the retail outlet ( $\alpha=0.87$ ). Data were analysed using the Chi-square test. Consumers' personality (extraversion  $\chi^2=28.23$ ;  $df = 1$ ;  $p<0.05$  and openness to experience  $\chi^2=38.31$ ;  $df=1$ ;  $p<0.05$ ) significantly influenced the choice of retail outlet. The result revealed that the majority of consumers who are high on openness to experience (38%) and introverted (38%) preferred shopping in the supermarket. The result further revealed no significant influence of gender and income on the choice of retail outlet. Consumers' personalities influenced the decision to buy in a supermarket or traditional market, therefore, retail outlet owners and managers should put into consideration the consumers' personalities when designing their outlets to suit the needs of these consumers.

**Keywords:** Retail outlets, traditional market, supermarket, personality, openness to experience

---

## **Introduction**

Traditional retail market shopping environments referred to as open-air markets have long been an important part of the culture of Nigerians and specifically Ibadan residents, meeting the economic, social and psychological needs of the people. These retail markets serve various purposes and deal in various commodities, for example, the Bodija, Sasa, and Oje markets majorly specialise in the sale of food items among other wares while clothes, shoes, gifts items, souvenirs and household utensils are readily available at Alesinloye and Dugbe market. These retail markets not only serve as a place for buying and selling but, as a social environment where various people from different classes and works of life meet, chat, bargain and satisfy their household needs. However, the introduction of western-style retail shopping environments as a result of globalization has begun to change this culture. Large-scale commercial developments, especially shopping malls are being developed in Ibadan, allowing consumers to choose between the available alternatives, that is, shopping malls/supermarkets or traditional/open markets. Consumer outlet selection is important to the management and survival of retail firms and it is equally important to consumer goods marketers. Selecting a retail outlet involves the same process as selecting a brand. Consumers recognize a problem that requires an outlet to be selected, engage in internal and possibly external search, evaluate the relevant alternatives and apply a decision rule to make a selection. For this study, retail outlets refer to a place where buyers and sellers gather to exchange goods and services and it has been classified into two groups; traditional open-air markets and supermarkets. Traditional markets are markets with little or no central control organization, which often lack refrigeration and do not process fresh foods into branded goods for sale (Trappey & Lai, 1997) while supermarkets are self-service stores that offer one-stop shopping, value for money and hold a large variety of products in pleasant surroundings (Cheeseman & Wilkinson, 1995).

Focusing on the food retail market, the food retail system has been greatly impacted by modernization. For most states and cities in Nigeria, including Ibadan, traditional retail outlets are being replaced by supermarkets and hypermarkets and thus dominating the food retail market. Presently, an increasing number of modern retail outlets are springing up in Ibadan, where an increasing population and rising income are resulting in demand for goods and quality food, and household items. As a result, consumers are faced with the dilemma of buying their convenience goods, that is, grocery items such as toiletries, vegetables, fruits, fresh meat, fish, cooking oil and dairy products from either the traditional market or supermarket. Selecting or making a choice about the retail market to patronise may be demanding because of the different features of the two types of available markets. Goldman (2000), identified the consumers' selective adoption of supermarkets and reported that those consumers who shop at supermarkets still patronise traditional outlets for fresh food (Meng, Florkowski, Sarpong, Chinnan, & Resurreccion, 2014). Some of the factors that guide consumer outlet's decision include; a clean environment and quality (Memery, Megicks, & Williams, 2006), service quality and low price (Hutcheson & Mutinho, 1998), parking space, availability of product variety, proximity (Kaufman, 1996), bargaining, discounts and salesmen behaviour (Rishi & Singh, 2012). These factors have been the focal point of much consumer research on the choice of retail outlet without so much consideration for the psychological and social factors that influence these decisions. Consumers have different personalities, needs and socioeconomic statuses that affect the stimulus-response of buying behaviour. While some consumers patronise the traditional market for fresh, direct-from-the-farm vegetables others may patronise supermarkets for imported vegetables that have been refrigerated and stored for

a while but has a brand name. Das (2014) confirmed that consumer store personality influences consumer store choice behaviour. Therefore, the change in income, consumer preference and development of supermarkets and hypermarkets in Ibadan demands investigation into factors that influences the consumer choice of retail outlet. This study, therefore, adds to the existing knowledge and literature by investigating the association between consumer personality and sociodemographic factors, and consumer choice of retail outlet.

Several factors associated with the choice of retail outlets have gained the attention of researchers in the investigation of consumer behaviour toward choosing where to shop for grocery items. Onyeagwara, Agu and Aja (2019) asserted that demographic factors such as family size, age, income, occupation, gender, education and marital status predicted the choice of buying outlet. In addition, it was revealed from their study that while product attributes such as product quality, assortment and sales service influenced consumers' choice of shopping outlet, price did not influence shopping outlet (Onyeagwara, Agu, & Aja, 2019). Reviewing a study on shoppers' attributes on supermarket store choice behaviour, Prasad and Aryasri (2010) reported among 1040 retail customers in India that supermarket choice behaviour is affected by monthly household income, age, proximity, family size, gender and education. It was specifically revealed that graduate and postgraduate consumers mostly preferred to shop for food and grocery items at supermarkets (Prasad & Aryasri, 2010). Goldman and Hino (2005) in their study on diagnosing the barriers to supermarket's market share growth in an ethnic minority community revealed that while socioeconomic factors do not influence preference for supermarkets, the freshness of perishable food made perception of traditional stores superior and served as an additional barrier to supermarkets share increase. Hence, marketers and retailers need to understand the factors that influence the choice of consumer's retail outlet and use this as a guide to make wares available, meet market demands and achieve sales objectives.

### **Objectives**

The main objective of this study is to investigate the influence of psychosocial (personality and socio-demographic) factors on consumers' choice of retail outlets (traditional market or supermarket) among consumers in Ibadan.

In specifics, the objectives of this study include:

1. To investigate the influence of consumers' personalities on the choice of retail outlet among Ibadan residents.
2. To investigate the choice of retail outlet between the male and female gender in Ibadan, Nigeria.
3. To investigate the choice of retail outlet between low-income earners and high-income earners in Ibadan, Nigeria.

### **Materials and Methods**

#### **Design**

This study utilised the cross-sectional survey research design that entailed no direct manipulation by the researcher. The variables of interest in this study include personality (Extraversion and openness to experience), socio-demographic factors (gender and income level) and choice of retail outlets (traditional market and supermarket). This design was found suitable to assess the choice of retail outlet of consumers in Ibadan.

### **Sampling**

A purposive sampling technique was used to collect the data for this study because of the need to purposively select the participants of the study base on the set inclusion criteria which include:

1. Participants must be 18 years and above
2. Participants must be residents of Ibadan

### **Participants**

Three hundred and thirty-six (336) Ibadan residents aged between 18 years and 56 years participated in the study. The respondents comprised a female majority of 178 (53%) and 158 (47%) males. In terms of academic qualification, the majority of the respondents 149 (44%) possessed a Bachelor's degree in Science, Art and Education inclusive of a Higher National Degree, 62 (18%) had a Master and Doctorate, while 54 (16%) and 71 (22%) respondents had Ordinary National Diploma and Secondary School Certificate respectively. Considering respondents' socioeconomic status, the majority of the respondents 192 (58%) earned at and below the minimum wage of thirty thousand naira while 144 (42%) respondents earned above the minimum wage.

### **Instruments**

Data was collected with the aid of a self-reported questionnaire designed by the researcher. The questionnaire had three sections. The first section assessed the socio-demographic characteristics of the respondents such as age, gender, level of income, religion, educational qualification and marital status. The second section of the questionnaire contained the NEO-Five Factor Inventory (Costa & McCrae, 1992) developed to measure personality. Though the scale is a 60-item inventory designed to measure dimensions of negative emotion, extraversion, openness to experience, agreeableness and conscientiousness, this study extracted the two dimensions that are of interest to the study and made use of 24 items centered on extraversion and openness to experience. The Cronbach's alpha generated for the 24 items for this study was 0.71. The third section contained the Choice of Retail Outlet Scale (CROS) developed by the researcher for this study. The CROS is a 19-item preference scale that measures consumer choice of retail outlet. Statements in the scale include "it is necessary for me to have a bargaining option when shopping grocery items" and "I feel safe shopping in an outlet with security personnel" and they were rated on a 5-point Likert response option with a score ranging from 5 to 1. Cronbach's alpha 0.87 was established for this study.

### **Data Collection Procedure**

The data for this study were collected using a structured questionnaire. The data were collected at three different traditional markets in Ibadan and three supermarkets with the permission of the directors of the supermarket. The researcher approached the respondents after their shopping and asked for their permission to voluntarily participate in the research. Filling out each questionnaire took around 7 to 10 minutes. In total, 400 questionnaires were produced and distributed but only 336 questionnaires were used for analysis because some respondents could not complete the questionnaire and some omitted some relevant questions. The 336 questionnaires that were filled were the ones used for analysis.

### **Data Analysis**

The collected data were analysed using GraphPad Prism (version 9.2.0). The analysed data provided answers to the research questions stated and Chi-square analysis was used because



of the categorical nature of the variables of interest.

### Result

The result of the collected data on the influence of personality (extraversion and openness to experience) and socio-demographic factors (gender and income) and interpretation are presented in Charts 1-4. The Chi-square contingency chart 1 revealed a significant difference between introverted and extroverted consumers with their choice of retail outlet in Ibadan ( $\chi^2=28.23$ ;  $df=1$ ;  $p<0.05$ ). The result revealed that the majority of the introverted consumers (38%) preferred the supermarket while only a few of the introverted consumers (18%) opted for the traditional market. It was further revealed that the majority of the extroverted consumers (27%) preferred the traditional market while just a few of the extroverted consumers (17%) opted for the supermarket.

Further analysis in chart 2 revealed a significant difference between consumers high on openness to experience and consumers low on openness to experience on the choice of retail outlet in Ibadan ( $\chi^2=38.31$ ;  $df=1$ ;  $p<0.05$ ). The result revealed that the majority of the consumers high on openness to experience (38%) preferred the supermarket while only a few of the consumers high on openness to experience (14%) opted for the traditional market. It was further revealed that the majority of the consumers' low on openness to experience (29%) preferred the traditional market while just a few of the consumers low on openness to experience (19%) opted for the supermarket. The Chi-square contingency chart 3 revealed a non-significant difference between males and females in the choice of retail outlet in Ibadan ( $\chi^2=1.90$ ;  $df=1$ ;  $p>0.05$ ). Chart 3 revealed that 27% of the male consumers preferred the supermarket and almost the same percentage (26% and 27%) of female consumers also indicated the supermarket and traditional market respectively as their preferred retail outlet. This result, therefore, indicates that gender does not influence the choice of retail outlet. The Chi-square contingency chart 4 revealed that consumers' socio-economic status does not influence the choice of the retail outlet ( $\chi^2=0.22$ ;  $df=1$ ;  $p>0.05$ ). The result revealed a non-significant difference between high-income earners and low-income earners in the choice of retail outlet. Chart 4 revealed that the same percentage (21%) of high-income earners indicated a preference for supermarkets and traditional markets and almost the same applies to low-income earners.

Chart 1: Showing the difference in Choice of Retail Outlet between Extroverted Consumers and Introverted Consumers in Ibadan

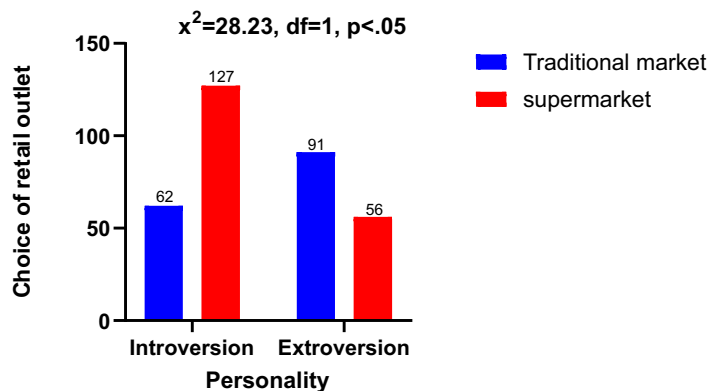

Chart 2: Showing the difference in the Choice of retail outlet between Low Openness to Experience Consumers and High Openness to Experience Consumers

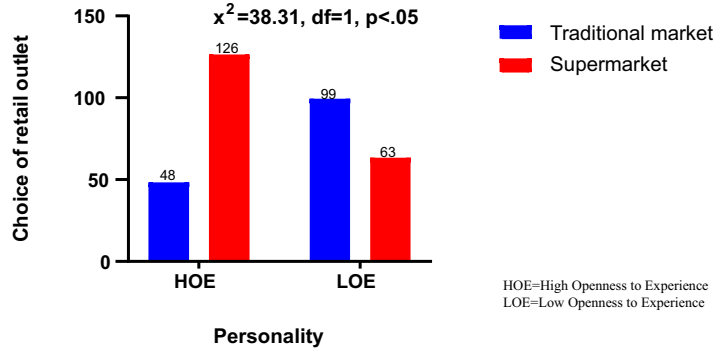

Chart 3: Showing the difference in Choice of Retail Outlet between Male and Female Consumers in Ibadan

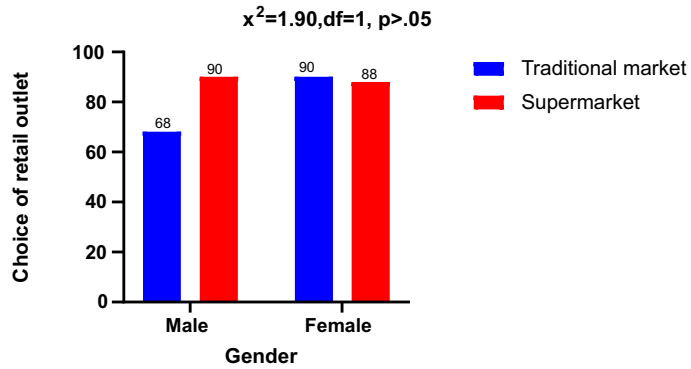
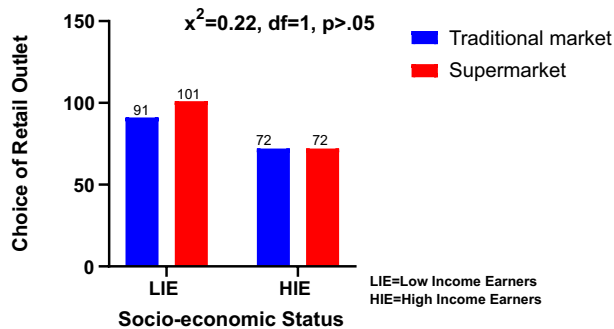

Chart 4: Showing the difference in Choice of Retail Outlet between High Income Earners and Low Income Earners in Ibadan



### Discussion

The result of this study indicates that the choice of retail outlet is influenced by consumers' personality which includes extraversion and openness to experience. The result implies that introvert prefers shopping in supermarkets while extrovert prefers shopping in traditional

markets. This result supports the notion that introverts prefer to shop in a supermarket; a focused environment where they do not need to bargain or entertain any form of social relationship and conversation with others while extroverts, because of the nature of their personality, prefer the traditional market where they can haggle prices, form relationships and bond with others in the process of buying their groceries.

The result further reveals that the majority of the consumers who are low on openness to experience prefer the supermarket while most of the consumers high on openness to experience prefer the traditional market. This result further supports the notion that openness to experience involves having an active imagination, seeking new experiences, preference for variety and curiosity (Costa & McCrae, 1992), therefore consumers high on openness to experience prefer supermarkets while those low on openness to experience prefer a traditional market that suits their conventional and traditional behaviour. Consumers low on openness to experience are often close-minded and prefer their routine; shopping in their familiar traditional markets rather than forming new experiences by shopping in a supermarket. Consistent with the findings of this study, Winter and Grebitus (2019) reported that consumers' personality influences store brand behaviour, though their study focused on personality dimensions of conscientiousness and neuroticism.

The result of this study further indicates that the choice of retail outlet is not influenced by consumers' gender and income. The result implies that there is no difference in the choice of retail outlet among male and female consumers and high-income and low-income consumers. In line with this study's findings, Oghojafor and Nwagwu (2013) reported among females in Lagos that income is not influenced by the choice of retail outlet for groceries. Contrary to this study's findings, Prasad and Aryasri (2010), Onyeagwara, Agu, and Aja, (2019) reported that gender and income predicted the choice of buying outlet.

### **Conclusion**

In conclusion, this study exposes that the choice of retail outlet is influenced by consumers' personalities which include extraversion and openness to experience and is not influenced by socio-demographic factors such as gender and income. The consumers' personality determines where the groceries of the household are bought and not the gender or income.

### **Limitation of the Study**

The study limited the data collection to two traditional markets and two supermarkets in Ibadan, this may not be representative enough for the entire retail outlets in Ibadan. Also, there could be respondents' bias where respondents give socially desirable answers since a self-report (questionnaire) tool was used for data collection.

### **Recommendations**

The decision of where to buy groceries can be stressful for most consumers especially when they are faced with various alternatives. Retail outlets and consumer brands should therefore put into consideration the consumers' personalities when designing their outlets to suit the purpose of these consumers.

A retail outlet can factor in various personality traits into a retail store by providing various sections that will cater to these personalities. A self-serviced closed roof section with goods beautifully displayed with price can be designed for introverts while an open roof section



where sales representatives can discuss and socialize can be made available for extroverts. Also, a traditional setting can be designed to exist with the modern supermarket to give room for both high openness to experience and low openness to experience consumers to shop.

## References

- Cheeseman, N. & Wilkinson, M. (1995). Food retailing in Taiwan: Developments, future directions and opportunities. Agribusiness Marketing Series, Q1 95028, Queensland, Australia: Queensland of Primary Industries.
- Costa, P. T. & McCrae, R. R. (1992). NEO personality inventory professional manual. Odessa, FL: Psychological assessment resources.
- [Das, G.](#) (2014). Store personality and consumer store choice behaviour: An empirical examination. *Marketing Intelligence & Planning*, 32 (3), 375-394. <https://doi.org/10.1108/MIP-07-2013-0116>.
- Goldman, A. (2000). Supermarkets in China: The case of Shanghai. *The International Review of Retail, Distribution and Consumer Research*, 10(1), 1-21.
- Hutcheson, G. D. & Mutinho, L. (1998). Measuring preferred store satisfaction using consumer choice criteria as a mediating factor. *Journal of Marketing Management*, 14, 705-720.
- Kaufman, C. F. (1996). A new look at one-stop shopping: A TIMES model approach to matching store hours and shopper schedules. *Journal of Consumer Marketing*, 13(1), 4-52.
- Memery, J., Megicks, P. & Williams, J. (2006). Ethical and social responsibility issues in grocery shopping: A preliminary topology. *Qualitative Market Research: An International Journal*, 8(4), 399–412.
- Meng, T., Florkowski, W. J., Sarpong, D. B., Chinnan, M. S. & Resurreccion, A. (2014). Consumer's food shopping choice in Ghana: Supermarket or traditional outlets? *International Food and Agribusiness Management Review*, 17, 107-130.
- Rishi, B. & Singh, H. (2012). Determinants of supermarket shopping behaviour in an emerging market. *Journal of Business and Retail Management Research*, 7(1).
- Oghojafor, E. A. & Nwagwu, K. (2013). Choice of shopping outlets for grocery products and the socio-economic profile of female consumers in Lagos Nigeria. *Journal of Sustainable Development Studies*, 4(2), 88-111.

- Onyeagwara, C. A., Agu, G. A. & Aja, E. E. (2019). Predictors of consumers' choice of buying outlets in Imo and Abia States, Nigeria. *Archives of Business Research*, 7(SP), 34-48. DOI: 10.14738/abr.73.2.6361.
- Prasad, C. J. & Aryasri, A. R. (2010). Shoppers' attributes on supermarket store choice behaviour in food & grocery retailing in India-an empirical analysis. *Journal of Business and Retail Management Research*, 4(2).
- Trappey, C. & Lai, M. K. (1997). Differences in factors attracting consumers to Taiwan's supermarkets and traditional wet market. *The Journal of Family and Economics*, 18(2), 211-224.
- Winter, S. T. & Grebitus, C. (2019). Effect of consumers' personality on store brand choice in grocery stores: Insights from France and Germany. *Journal of International Food and Agribusiness Marketing*, 31(4), 400-416. <https://doi.org/10.1080/08974438.2018.1533507>



## Information and Communication Technology Adoption and the Growth of Small Medium Enterprises in Lagos Metropolis, Nigeria

<sup>1</sup>Oyewole Kehinde Samuel and <sup>2</sup>Akindele Oluwafemi

<sup>1</sup>Department of Accountancy,  
Federal Polytechnic Ile-Oluji, Ondo State, Nigeria

<sup>2</sup>Department of General Studies,  
Federal Polytechnic Ile-Oluji, Ondo State, Nigeria

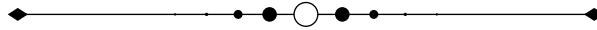

### **Abstract**

**T**he study used cross sectional study design and data were collected from business owners operating within the divisions of Lagos Metropolis. The study found out that the level of ICT adoption in Lagos Metropolis was moderate. ICT adoption was mostly marked with establishment of separate IT department, use of bulk SMS, printers, scanners and photocopiers. Specialized ICT skills, regular updates and outsourcing of ICT functions appeared to be a key challenge businesses face in ICT adoption. The findings however, indicated that growth of SMEs is a conglomeration, of which adoption of ICT is a microcosm. The study recommends that Government of Nigeria through Ministry of Science Technology and Innovation and Ministry of Finance Planning and Economic Development should consider promoting ICT business growth by sponsoring business software development, and distributing the same at subsidized costs. Training institutions should strengthen the ICT training programs by aligning them to the required job demands as dictated in the field of business. Government should also promote the application and adoption of ICT e-business by slashing the exorbitant taxes charged on the use of these products. Government should stimulate entrepreneurship development training to curb the shortfalls in staff competence, individual job creation and profitability skills.

**Keywords:** ICT, SMES, Adoption, Business, Growth

---

### **Contextual Background**

The rapid growth and development of information and communication technologies (ICT) has greatly influenced how businesses are operated and managed in the 21<sup>st</sup> century. Today's businesses are faced with evolution and rapid changes as a result of the wide diffusion of information and communication technologies within organizations. The adoption and usage of ICT brings along competitiveness and thus leads to economic growth for economies that are able to exploit such opportunities (Steinfeld, LaRose, Chew, & Tong, 2012). ICT gives SMEs a competitive advantage in the evolving economy since Managers rely on ICT to store data, share information and make informed decisions. Thus, ICT has a potential to support more efficient and effective decision-making relevant, to the performance of SMEs businesses and hence creating competitiveness and innovativeness for business growth (Barba-Sanchez, Martinez-Ruiz, & Jimenez-Zarco, 2007). Franco, Santo & Ramalho (2014) noted that fast-paced technological innovation is fueling development and transforming multiple business functions. The strategic orientations of SMEs are important in that it influences the extent to which SMEs would analyze its demand and competitive environments. Strategic orientations are also indicators of the way SMEs adopt and use information about market opportunities and employ product market innovations that brings growth (Aragon-Sanchez & Sanchez-Marin, 2005). SMEs are driven to adopt appropriate ICTs for improving their internal processes, improving their product through faster communication with their customers, and better promotion and distribution of goods and services through online presence. Although ICTs are much cheaper than before, they still represent a considerable investment for SMEs that usually lack such funds. Besides, SMEs usually do not have the appropriate skills available in-house and thus have to train existing staff or outsource most ICT functions of the organization. Whatever the situation, ICT remains a key pillar for modern business transformation and innovation for better production of products and services.

### **Problem Statement**

Government of Nigeria in its restructuring program is encouraging Nigerians to start own businesses to reduce the level of unemployment and exploit the current West African Markets. As a result, many SMEs have come up in areas such as Entertainment, Transport, Metal Fabrications and Food and Agriculture. However, SMEs may not understand the ways in which ICT could enable them to operate businesses more efficiently or cost effectively. Thus, most of these businesses do not show growth signs and remain struggling due to various challenges. Consoli (2012) noted that SMEs face various barriers to ICT adoption partly because SMEs have limited resources, technology and capabilities although the less complicated structure allows smaller companies more flexibility to changes. Similarly, (Aleke, Ojiako, & Wainwright, 2011) observed that the barriers to adoption of ICT in SMEs in rural areas include lack of awareness, top management support and infrastructure. National Small Business Survey Report (2015) corroborated that it has not been easy for SMEs to adopt e-business partly due to the continuous change of e-business technology and the varying needs of the local and global businesses. Sempala & Mukoki (2018) stated that the government needs to improve the ICT infrastructure coverage to enable Macro, Small and Medium enterprises to utilize the online market-base that can enhance sales.

The growth and development of technology requires one to keep pace with the changing environment needs and this requires the SMEs to keep a brace with the new technology. The ever-changing ICT environment requires regular updates and training to remain a brace of development and opportunities (Modinmogale & Kroeze, 2011). It is thus apparent that in

spite of efforts being made by many organizations to use ICT solutions to support their supply chain strategy, challenges still exist that inhibit effective integration (Christopher, 2011). Lack of internal capabilities, high cost of ICT acquisition and lack of information about suitable ICT solutions and implementation are some of the limitations. It is upon this background that this study assessed better ways of handling such challenges and presents better recommendations to address such challenges.

### **Objective of the Study**

1. To determine the level of ICT adoption in to business transactions by SMEs.
2. To establish the factors hindering effective ICT adoption into businesses by SMEs.
3. To analyze the ICT adoption and its impact on profitability of SMEs businesses
4. To propose strategic interventions for effective adoptions of ICTs by SMEs.

### **Literature Review**

#### **Information and Communication Technology**

Technology advancement and usage of ICT has always been part of organizational efficiency and organizations take investment in technology as part and parcel of their annual plan to widen the market share (Aleke, Ojiako, & Wainwright, 2011). The increase in the usage of ICT in the emerging economies has presented new frontiers for technology to enhance SMEs operations and management. ICTs are universally recognized as an essential tool in improving the competitiveness of the economy in a country, and have significant effects on the productivity of companies (Olviera & Martins, 2011). ICT gives SMEs a competitive advantage in the new economy and it has the potential to support more efficient decision-making relevant to the performance of SMEs and make them more competitive and innovative, thus generating growth (Barba-Sanchez, Martinez-Ruiz & Jimenez-Zarco, 2007). Aguilera, Cuevas-Vargas & Gonzalez (2015) observed that adoption of ICT plays a key role in developing business strategies that enable businesses, especially SME in improving their competitiveness in a globalized, changing and competitive market today. Similarly, (Olise, Anigbogu, Edoko, & Okoli, 2014) argued that the influence of globalization on SMEs that has compelled many of them to adopt (ICT) solutions in order to survive among increasingly competitive supply networks. The benefits of application of ICT in the enhancement of SMEs services is not only limited to cost reduction benefits alone, the innovation is found also to have significant contribution to giving access to customers residing outside the branch network and create opportunities for effective cross-selling amongst others thus earning profitability (Sachan & Ali, 2006). Ollo-Lopez and Aramendia-Muneta (2012) established that adoption and usage of ICT represent the fundamentals of competitiveness and economic growth for companies and countries those are able to exploit. Asta and Rimantas (2013) noted that ICT has an impact on the improvement of external and internal communication and that ICT plays a major role in innovation performance of SMEs. Ongori and Migiro (2010) noted that new technological innovations enable and facilitate a broad range of business activities related to the storage, processing, distribution, transmission and reproduction of information. Accordingly, (Ghobakhloo, Sabouri, Hong, & Zulkifli, 2011) observed that adopting ICT in business operations and management will support SMEs in cost saving, organizational effectiveness, improvement of services to customers and suppliers, access to new business opportunities and market information, competitiveness and internationalization. Osei and Harvey (2011) observed that investments in ICT by SMEs tend to increase profitability (Return on Assets and Return on Equity) for high ICT level SMEs than for lower ICT level SMEs. The adoption of ICT in business usually entails additional costs, which may include training of employees, continuous system upgrade, which may need to be taken into account



especially in the case of SMEs (Tan, Chong, Lin, & Eza, 2010). Khalifa (2016) noted that research and development and innovation profile of firms has been frequently linked to the adoption and/or use of new technologies. Ioannis, Alexandra, Efthymia and Aggelos (2017) observed that specialized ICT skills are probably more significant than general scientific knowledge for the engagement of SMEs in e-commerce. From the organizational perspective, a decentralized structure of firm's decision-making process along with the presence of visionary leaders is crucial in facilitating adoption of ICT in the operations and management of SMEs. Accompanying technological developments, expectations are continually increasing for businesses to improve the effectiveness and efficiency of existing processes and generate value through the exploitation of new opportunities (Ashurst, Cragg & Herring, 2012). Similarly, (Jones, Packham, & Beckinsale, 2013) observed that digital technologies represent a key concern for SME managers and policy makers. George, Yanqing, Anne-Marie & Jared (2017) argued that business performance appears to improve as SMEs organizations adopt information technology to facilitate greater market communication and increased exposure to online shoppers. Furthermore, irrespective of the level of sophistication of the interface, the design of the E-commerce technology and the high information intensity types of the industry improves performance. It has been observed that internet technologies have entirely eased the way towards an electronic economy that enables innovative business tactics (Lecic-Cvetkovic, Omerbegovic-Bijelovic, Zanic, & Janicic, 2015).

Similarly, website usage has been considered as a tool to leverage competitive advantages in a diverse range of activities (Mohammadi & Abrizah, 2013). The greater the perceived relative advantage of having an online presence, the greater the website continued intention in SMEs. Ramayah, Niu, Seyedeh & Syed (2016) observed that SMEs are likely to continue to adopt their website when cost of the technology is reasonable and continue to drop as more service providers come to the market. Kumar, Singh & Shankar (2016) observed that to achieve competitive advantages SMEs should strategically implement collaboration and information sharing practices in their supply chains. Gupta and Narain, (2012) noted that deployment of IT in SMEs is helpful in better inventory control, reducing cost and time and improving customer services. ICT has surpassed the role of support services or only electronic data processing. The devices especially the internet and modern computer email facilities have further strengthened early modernization like websites, teleconferencing and fax. Other ICT devices include data recognition equipment, factory automation hardware and services, tele-computing and teleconferences using real time and online system (Adeoti, 2005). Polasik & Wisniewski (2008) observed that as the internet use became popularized in the 90s by most SMEs, there was a marked proliferation of e-commerce by most SMEs and this increased on communication and profitability. Ovia (2005) corroborated that ICT has brought far reaching revolution in societies, which has tremendously transformed most business scenes. Nasir and Zhu (2018) noted that lack of e-commerce skills and absence to innovation awareness among the society was the major factor that influenced the adoption of electronic commerce within the SMEs in the developing economy. The OECD, (2017) reports confirmed that the situation of the costs of adopting and implementing ICT resources and upgrading e-commerce network system in many organizations is not very satisfactory in many developing economies. Ghobakhloo and Tang, (2013) augmented that it is clear that the high cost of ICT infrastructure in many developing economies does not allow SMEs to adopt new technologies and influence the growth of e-commerce. Ghobakhloo and Tang, (2013) and Hachimi *et al.* (2017) noted that the size and structure of the organization were the most frequently considered factors in e-commerce adoption. Kiplangat, Shisia and Asienga (2015) noted that

the knowledge in ICT Innovation among the employees have a significant influence on the adoption of e-commerce among the SMEs. Agbolade (2011) observed a positive relationship between Banks profitability and adoption of ICT. This implies that a marginal change in the level of investment and adoption of ICT in the banking industry results to a proportionate increase in the profit level.

### **Small Medium Enterprises (SMEs)**

SMEs have played a major role in economic growth of national economies in many countries and contribute significantly to employment creation (Higon, 2011). There is no universally accepted definition of SMEs in Africa, thus this study adopts the Government of Nigeria's classification of SMEs as business firms employing 5-50 people (Small Scale) and 51-500 people (Medium Scale) (Kasekende & Opondo, 2003; UBOS, 2003; Okello-Obura 2011, 2012). SMEs operate in nearly all industrial sectors of the economy, represent more than 90per cent of formal enterprises, and contribute to over 50per cent of employment and Gross Domestic Product (GDP) (Akinbiade, 2015). Even though SMEs globally have similar characteristics, the environments within which they operate affect their profitability. The need to understand the impact of SMEs management practices would have on the growth and profitability of SMEs is therefore critical to provide policy recommendation by all stakeholders. The potential advantages of the SMEs in developing country like Nigeria are many. First, they use less capital per worker than large firms do, because of the differences in the technology used to make the same products (Private Sector Foundation Uganda2014). Similarly, (Mandl, 2009) argued that SMEs use resources that might not be drawn into the development process such as workers with little formal training who learn on the job or those who may not use the banking systems but who may invest in their own firms. Aguilera-Enriquez, Gonzalez-Adame & Rodriguez-Camacho (2011) argued that SMEs need to modernize their management and production using technologies that can help compete in the future and include systems that can improve their functions to be more productive. Binuyo & Aregbeshola (2014) noted that the study noted that the use of ICT increases returns on capital employed as well as return on assets. The study also noted that more of the contribution to performance comes from ICT cost efficiency compared to investment in to ICT. Rakibul, Abu- Naser, Adnan & Yukun (2015) noted that government should promulgate rules in favor of SMEs by easing the coverage and making ICT adoption easily available and accessible to all. Mokaya (2012) posited that the government should develop an appropriate programme to encourage ICT adoption by SMEs and support training programmes that develop the capacity of SMEs. In other words, governmental policies should be favorable enough for new firms to enter into the venture. Aguilera, Colin & Hernandez, (2013) observed that adoption of appropriate technological tools enables SMEs to have systems to accurately monitor their finances and administrative processes, improving their competitive level. Eton, Mwosi, Mutesigensi and Ebong (2017) noted that SMEs should embark on increased business diversification and this would increase their productivity levels thus leading to increased profit.

Luis, Hector & Marthe (2015) noted that ICT has helped the SMEs to receive orders from customers and making them get in touch with suppliers when ordering, support management of the company in project planning, development of production process, improvement of machinery and equipment and the development of information technology. Lee, Park, Yoon & Park (2010) observed that new business models for ICT provide SMEs with access to new markets and new sources of competitive advantage. Similarly, (Maldonado, Sanchez, Gaytan

& Garcia, 2012) found out that SMEs with greater use of ICT gains greater performance. It can thus be confirmed that ICT represents a great opportunity for companies, especially SMEs to improve their level of competitiveness. However, it has been argued that SMEs are sometimes able to exploit ICT opportunities and adopt ICT more easily than larger organizations, simply because of the flexibility advantage they possess that makes their decision-making faster (Awa, Eze, Urieto & Inyang, 2011). Limited access to finance has been cited as the major hindrance to the development of SME (Akterujjaman, 2010). The major hindrance towards ICT diffusion is government support and poor physical infrastructure as posited by (Irefin, Abdul & Tijani, 2012). Being a major player in the economy, SMEs are urged to become more resilient and competent to face the challenges in today's knowledge economy. Wong *et al.* (2013) observed that the failure of SMEs to adopt ICT with globalization and rapid changes in technologies might lead them to cease the business within the first five years of operations. Buyinza, Mutenyo, Kakande and Banga (2017) noted that providing business training, easing access to credit, business education and record keeping are required to promote SMEs start-up sizes and increased performance. Yeboah (2015) complemented that the educational qualifications of the entrepreneurs and the size of the enterprise had the most significant influence on the growth of SMEs. The owners of the SMEs must be educated, even if it is not by formal schooling but periodically attend short trainings like seminars and workshops to attain the requisite knowledge to support business growth. Mutesigensi, Eton, Ebong and Mwosi (2017) noted that government and other stakeholders should provide training on financial management to SMEs to ensure that they get basic knowledge to help them in their daily operations of businesses. These would also build the culture of relationship with all stakeholders both internal and external. Urban & Naidoo (2012) argued that lack of operational skills threatened the survival of SMEs thus entrepreneurs should have expertise in all functional areas of business. Douglas, Douglas, Muturi and Ochieng (2017) noted that maintaining good relationships with customers, having a good product or service, having good marketing skills and creating brand customers are critical success factors in SME businesses.

### **Methodology**

The study used cross sectional design and data were collected from respondents operating businesses within the five divisions of Lagos Metropolis, which included Ikeja, Alimosho, Surulere, Lagos Island and Ikorodu. The SMEs investigated included Small medium and Large SMEs. A total of 250 respondents were targeted with each division having 50 respondents using stratified sampling technique. In all cases, the study targeted merchandize, service, and manufacturing and production business owners. However, a total of 223 businesses participated, of which 32 (14.3%) were merchandize type of business, 110 (49.5%) were service providers, 44 (19.8%) were manufacturers while 36 (16.5%) were production business. The structured and closed ended questionnaires were developed and used to cater for all categories of SMEs Questionnaires were used because of their ability to reduce bias alongside increasing the quality of data collected (Sekaran, 2006). Factors analysis was used in determining the accuracy and measuring the instrument. Cooper and Schinder (2011) observed that factor analysis determines the patterns among the variables, which determine the combinations among the variables to a manageable size. Correlation was used to establish the strength of the relationship between Information and Communication Technology adoption and the growth of Small Medium Enterprises in Nigeria. Regression analysis was used to provide a linear prediction of SMEs growth.



Table1: Adoption of ICT

Results Variable List	Unimportant	Neutral	Important	Mean	Std.
1.Establishment of separate IT department	37.2	21.7	41.2	3.12	1.300
2. Use of bulk SMS	42.9	26.1	31	2.91	1.255
3. Use of printer, photocopier and scanner	43.4	17.7	38.9	2.90	1.430
4. Use of landline telephone	43.9	31.9	24.3	2.69	1.218
5. Use of computer systems	52.6	15.5	31.9	2.61	1.475
6. Use and access to internet	53.1	18.6	28.3	2.61	1.404
7. Use of business software	53.5	24.3	22.1	2.57	1.250
8. Use of emails	52.2	19.5	28.3	2.53	1.405
9. Use of company website	65	7.1	27.9	2.43	1.640
10. Use of mobile phones	60.1	12.8	27	2.38	1.397
<b>Average</b>	<b>50.4</b>	<b>19.5</b>	<b>30.1</b>	<b>2.68</b>	<b>1.38</b>

To understand the level of adoption of ICT in Nigeria, the research examined the importance attached to adoption of ICT by different businesses. Participants had to make choice on how they perceived the importance of the different ICT facilities. Participants attached much importance to establishment of separate IT department (41.2%), use printers, scanners and photocopier (38.9%) and use of bulk SMS (31.0%). Important to note is that 37.2per cent could not see the importance of establishing a separate IT department in their business while 43.4per cent could not see the importance of printer, scanner and photocopier to their business. Least importance was rendered to the use of business software (22.1%) and use of landline telephones (24.3%). The statistics suggest that very few of the businesses investigated were applying specialized business software in their business. While the specific software could not be established, those in services (secretarial, ICT applications, hotels) and perhaps manufacturing could have had specific business software in their business. The seemingly least importance attached to landline telephones (43.9%) could be attributed to the changing technology in communication, which has transited to use of mobile phone handsets than ever before. Similarly, least importance was rendered to the use of mobile phones (60.1%) perhaps because it is interpreted as a communication device and not a computerized device that can contribute to business growth. The statistics indicated that 65.0per cent saw the use of company website as unimportant. This indicates how low businesses are in the adoption of ICT. In the absence of a website, how can the business be popularized to the outside world? On the whole, 30.1per cent indicated adoption of ICT to be important while 50.4per cent indicated the adoption of ICT as unimportant. The majority who indicated the unimportance of adoption of ICT were perhaps those in merchandize and production.

The findings indicated a moderate level of ICT adoption (mean = 2.68; std. = .138). Though in moderate levels, establishment of a separate IT department (mean = 3.12; std. = 1.300), use of bulk SMS (mean = 2.91) and use of printer, copier and scanner (mean = 2.90; std. = 1.255). The statistics imply that the few business organizations that were adopting ICT had a separate IT department, were using bulk SMS and had printers, copiers and scanners in their businesses. Low levels of adoption of ICT were associated with use of mobile phones (mean = 2.38) and use of a company website (mean = 2.43). Meanwhile, the businesses investigated could barely support a website, implying they could at least afford the use of mobile phones. However, the use of mobile phones appeared with a low mean perhaps because mobile phones are not considered as ICT facilities. Nonetheless nearly all the businesses investigated used mobile phones in their operations in some way than any other ICT facility. On the whole, the study indicated a moderate level of adoption of ICT in SME businesses.

Table 2: Challenges of Adoption of ICT

Variable List	Disagreement	Neutral	Agreement
1. ICT requires specialized skills, which we do not have	30.6	14.6	54.9
2. ICT requires regular updates	32.7	15.9	51.3
3. We find it expensive to outsource ICT functions	30.5	19	50.5
4. We find lack funds to invest in ICT	30.5	21.2	48.3
5. ICT require regular training	37.1	15	47.8
6. We lack information about suitable ICT solutions	25.2	27	47.8
7. Most of our business are lacking awareness about ICT	37.6	15	47.3
8. Adopting ICT involves high costs of acquisition	32.3	21.7	46
9. We still have low ICT infrastructure coverage	38.5	18.1	43.4
<b>Average</b>	<b>32.8</b>	<b>18.6</b>	<b>48.6</b>

Source: Field data, 2022

In line with the challenges business owners encountered in the adoption of ICT, 54.9% pointed to the need for specialized ICT, which they apparently do not have; 51.3% pointed to the need for regular updates while 50.5% pointed to the need for outsourcing of ICT functions, which are very expensive to the business. The statistics in Table 2 further suggest that businesses find it hard to adopt ICT basically because of the specialized skills requirement and the associated costs. In this regard, 48.3per cent of the respondents claimed to lack funds to invest in ICT, 47.8per cent claimed that ICT requires regular training, which they may not have or afford. In all these cases, the research found that the most limiting factor to ICT adoption is the financial constraint. On the whole, 48.6per cent agreed to face challenges in adopting ICT in business while 32.8per cent disagreed. While the disagreement does not indicate absence of challenges, they indicate the level to which they are affected by the challenges investigated in the study. For example, the 38.5per cent who disagreed on having low ICT infrastructure coverage suggest that the problem exists but does not heavily affect their adoption of ICT.

Table 3: Growth of SMES

Variable List	Disagree ment	Neutral	Agreement
1. This business efficiently utilizes capital to generate profits	44.7	19.5	35.9
2. This business is registering increasing assets	47.4	22.1	30.6
3. We have increased levels of customer orders	64.6	5.8	29.6
4. This business is registering steady increase in income	50.4	19.9	29.6
5. This business is selling multiple products	49.1	21.7	29.2
6. We have a wider access to new markets	51.8	19.5	28.8
7. This business has a cheap source of raw materials	58.8	13.7	27.4
8. This business has enough cash to sustain its operations	44.7	27.9	27.4
9. This business has a cheap source of raw materials	58.8	13.7	27.4
10. This business is registering steady increase in capital	46	27	27
<b>Average</b>	<b>51.6</b>	<b>19.1</b>	<b>29.3</b>

Source: Field data, 2022

The findings on growth of SMEs indicated that 35.9per cent of the businesses were efficiently

utilizing their capital to generate profits and 30.6per cent were registering increasing assets. These statistics are very low to suggest stable growth of SMEs. In fact 64.6percent disagreed to increasing their level of customer orders, 58.8per cent disagreed to having cheaper sources of raw materials, and 51.8 per cent disagreed to having a wider access to new markets while 50.4per cent disagreed to registering a steady increase in income. These statistics suggest numerous unearthed challenges; which businesses undergo to grow. The statistics further suggest that most of the businesses investigated find it hard to sustain and or increase customer orders due to challenges associated to raw materials and markets. Overall, 29.3 percent of the participants agreed to the claims raised in this research on SMEs growth while 51.6 percent disagreed. These statistics suggest staggering levels of business growth, though the current study could not succinctly establish the level of staggering.

Table 4: Adoption of ICT and SMEs growth

Coefficients	Coefficients				
	B	Std. Error	B	t	Sig.
(Constant)	.671	.113		5.929	.000
ICT Adoption	.757	.040	.786	19.041	.000
R	.786				
R Square	.618				
Adjusted R Square	.616				
Std. Error of the Estimate	.57964				
Regression	121.8				
Residual	75.3				

- a. Dependent Variable: SMEs Growth
- b. Predictors: (Constant), ICT Adoption

The relationship between adoption of ICT and growth of SMEs ( $r = .786$ ;  $\text{sig.} < .05$ ) was found

to be strong and significant. This means that any change in the adoption of ICT by government, business owners, media and schools are likely to generate a strong and positive change in the growth of small and medium enterprises. The statistics also indicate that adoption of ICT is likely to affect SMEs growth by 61.6% as evidenced from (Adjusted R Square = .616). This suggests that Adoption of ICT has a high impact on promoting SMEs growth. However, the remaining 38.4 percent unaccountable by adoption of ICT implies the existence other sets of factors that are responsible for the growth of SMEs around Lagos Metropolis. Potentially, a unit-change in adoption of ICT is likely to generate 78.6percent amount of change in growth of SMEs around Lagos Metropolis. ANOVA results indicate that regressions sum of squares (121.8) is higher than the residual sum of squares (75.3). These statistics indicate that the current model is adequate in explaining the level of variations in growth of SMEs around Lagos Metropolis.

### **Discussion**

The study found a moderate level of ICT adoption on growth of SMEs in Lagos Metropolis. This was indicated by establishment of a separate IT department, the use of bulk SMS and use of printers, scanners and photocopiers. The study agrees with (Migiro, 2010) who noted that new technological innovations enable and facilitate a broad range of business activities related to the storage, processing, distribution, transmission and reproduction of information. The scanners, photocopiers and printers process and reproduce information for business consumption while bulk SMS improve external communication, improves access to business opportunities and market information. Similarly, the printers, scanners and photocopiers reduce the costs of producing and storing information, which helps the business to remain competitive. The findings however disagree with Tan, Chong, Lin and Eze, (2010) who found that the adoption of ICT in business usually calls for additional costs related to training of employees and upgrading of the system, which costs the business may be lacking. ICT is a new field, which many have embraced, yet few carry practical skills in it. However, since the world of business dictates the use of modern technology, business owners have no option than to invest in the training of their employees in ICT skills. The study found the usage of internet and company website as unimportant component of ICT in business. This is characteristic of SMEs, which embrace the traditional approaches to communication and access to information. Today, access to the internet is no longer an option to business owners as before. Most of the businesses can keep and remain in touch with their customers and suppliers via the net. The results therefore disagree with (Lecic-Cvetkovicetal, 2015) who posited that the internet technologies have eased the way towards an electronic economy that enables innovation and business tactics. Internet technologies can boost business growth only when businesses invest in internet technology. However, when business owners consider the costs associated and shun away from such investment, little business growth is likely to be realized. The study further found that ICT requires specialized training, which most businesses lack. The findings agree with (Nasir & Zhu, 2018) who established that lack of e-commerce skills and absence of innovation awareness are among the major factors that hinder adoption of electronic commerce within SMEs in the developing economies. It can be argued that businesses that have labored to invest in the ICT skills of their employees appear to be performing well. Though this may not call for sophisticated technology that might sound expensive, a little application of ICT for example in printing and photocopying can reduce the business' operational costs on secretarial services.

The study found a positive and strong relationship between ICT adoption and growth of SMEs. A variation in the level of ICT adoption was likely to positively and strongly vary the level of growth of SMEs. The findings agree with (Agbolade, 2001) who found a positive relationship between bank profitability and adoption of ICT. Profitability is a good measure of a business' financial performance, whose increasing level indicates business growth. In a similar study, (Luis, Hector & Marthe, 2015) found ICT to be helpful to SMEs in receiving orders from customers in addition to helping business owners to get in touch with their suppliers. These benefits span beyond the traditional communication approaches of postal addresses. The use of internet, webmail, bulk SMS and website communication can contribute greatly to communication between the business, partners, customers and suppliers.

### **Conclusion**

The study examined the level of ICT adoption around Lagos Metropolis, which was found to be moderate. ICT adoption was mostly marked with establishment of separate IT department, use of bulk SMS and use of printers, scanners and photocopiers. These are the least ICT adoptions that are likely to open gates to massive adoption of ICT. A mere identification of an IT department pushes management and directors to investing in IT. Similarly, bulk SMS reduce the costs of communication the same way printers, photocopiers and scanners reduce expenditure on secretarial services. Mobile phones in this study appeared among the least indicators of ICT adoption in Lagos Metropolis possibly because they are not considered as an ICT facility. Otherwise, lay reasoning points to mobile phones as the most applied ICT facility in business. Any reporting that contradicts this reasoning can be associated to misinterpretation of the research instrument. The need for specialized ICT skills, regular updates and outsourcing of ICT functions appeared to be fundamental among the challenges businesses face in ICT adoption. Businesses will keep staggering in growth for fear of the costs involved in adopting ICT. However, if looked at from the viewpoint of using bulk SMS and mobile phones, ICT can easily be adopted by any business at any stage of growth. Relative to the adoption of ICT, businesses indicated to utilize their capital efficiently and were registering increasing assets and orders. This level of business growth is likely to increase especially among those businesses that may adopt ICT in their operations. This conclusion is drawn from the strong and significant relationship that was exhibited between adoption of ICT and growth of SMEs. This research however, noted that growth of SMEs is a conglomeration, of which adoption of ICT is a microcosm.

### **Significance of the Study**

As a practical contribution to the practice of ICT, this paper brings to light the fact that though mobile phones seem to be ignored as ICT facilities, they considerably reduce communication costs of doing business. Bulk SMS speed communication at affordable costs leave alone reaching a wider clientele within the shortest time possible. This paper contends that businesses of all types can enjoy steady growth if they scale their adoption of mobile phones (the least of ICT facilities) in their business operations. As a theoretical contribution, this paper establishes a misconception held among business operators regarding the adoption of ICT in business. A number of business operators are not aware of the fact that mobile phones are ICT facilities. Mobile phones are indeed ICT facilities whose adoption in business can reduce operational costs. Beyond looking to setting up a separate IT department as the only way of adopting ICT in business, business operators ought to exploit the benefits mobile phones bring to their businesses. It is in reference to such misconception that adoption of ICT in business perceived to be costly.



### **Recommendation**

Most of the growing businesses find it hard to adopt ICT in their operations because of the related costs of installation and maintenance. Government of Nigeria, through Ministry of Science, Technology and Innovation and Ministry of Finance Planning and Economic Development should consider promoting business growth by sponsoring business software development and distributing the same at subsidized costs. Universities and tertiary institutions should strengthen their ICT training programs by aligning them to the required job demands as dictated in the field of business. Government should promote the application and adoption of ICT e-business by slashing the exorbitant taxes that are charged on the use of these products. Government should stimulate entrepreneurship development training to curb the shortfalls in staff competence, individual job creation and profitability skills.

### **References**

- Adeoti, J. O. (2005). Information technology investment in Nigerian manufacturing industry: The progress so far. *Selected papers for the 2004 Annual conference*.
- Adewoye, J. O., & Akanbi, T. A. (2012). Role of information and communication technology investment on the profitability of small medium scale industries - A case of sachet water companies in Oyo State, Nigeria. *Journal of Emerging Trends in Economics and Management Sciences*, 3(1), 67 - 71.
- Agbolade, O. K. (2011). Information and communication technology and banks profitability in Nigeria. *Australian Journal of Business and management Research*, 1(4), 102.
- Aguilera-Enriquez, L., Gonzalez-Adame, M., & Rodriguez-Camacho, R. (2011). Small business competitiveness model for strategic sectors. *Advances in Competitiveness Research*, 19(3/4), 58-73.
- Akinboade, O. A. (2015). Determinants of SMEs growth and performance in Cameroon's central and littoral provinces manufacturing and retail sectors. *African Journal of Economic and Management Studies*, 6(2), 183-196.
- Akterujjan, S. M. (2010). Problems and prospects of SMEs loan management: A study on Mercantile Bank Limited, Khulna Branch. *Journal of Business and Technology (Dhaka)*, 5(2), 1-10.
- Aleke, B., Ojiako, U., & Wainwright, D. W. (2011). ICT adoption in developing countries: Perspective from Small-Scale agribusiness. *Journal of Enterprise Information Management*, 24(1).
- Aguilera, E. L., Cueva-Vargas, H., & Gonzalez, A. M. (2015). The impact of information and communication technologies on the competitiveness: Evidence of manufacturing SMEs in Aguascalientes, Mexico. *International Review of Management and Business Review*, 4(3). Aragon-Sanchez, A., & Sanchez-Marin, G. (2005). Strategic orientation, management characteristics and performance: A study of Spanish SMEs. *Journal of Small Business Management*, 43(3), 287-308.

- Asta, T. & Rimantas, G. (2014). ICT impact on SMEs performance. *Procedia Social and Behavioral Sciences*, 110(2014), 1218-1225.
- Awa, H., Eze, S., Urieto, J., & Inyang, B. (2011). A major determinant of information technology (IT) adoption by SMEs in Nigeria. *Journal of System and Information Technology*, 13(2), 144-162.
- Barba-Sanchez, V., Martinez-Ruiz, M. D., & Jimenez-Zarco, A. I. (2007). Drivers, benefits and challenges of ICT adoption by small and medium sized enterprises (SMEs): A literature review. *Problems and Perspectives in Management*, 5(1), 104-115.
- Binuyo, A. O., & Aregbeshola, R. A. (2014). The Impact of Information and Communication Technology (ICT) on Commercial Bank Performance: Evidence from South Africa. *Problems and perspectives in management*, 12(3).
- Buyinza, F., Mutenyo, J., Kakande, N., & Banga, M. (2017). Determinants of firm start-up size and performance of Small and Medium Enterprises (SMEs): Empirical evidence from Uganda. *Journal of Applied Business and Economics*, 19(12).
- Christopher, M. (2011). *Logistics and supply chain management: Creating value-adding networks, 4th edition*. Edinburgh: Prentice Hall.
- Consoli, D. (2012). Literature analysis on determinant factors and the impact of ICT in SMEs. *Procedia-Social and Behavioral Sciences*, 62, 93-97.
- Dalis, D. T., & Anyatonwu, E. O. (2017). Effect of ICT Adoption on Competitive performance of Banks in an Emerging Economy: The Nigerian Experience. *Journal of humanities and Social Science*, 22(8).
- Douglas, J., Douglas, A., Muturi, D., & Ocheing, J. (2017). An exploratory study of critical success factors for SMEs in Kenya. *20th International Conference, University of Verona*. Verona, Italy.
- Eton, M., Mwosi, F., Mutesigensi, D., & Ebong, C. D. (2017). Credit financing and performance of SMEs in Lira Municipality, Uganda. *Research Journal of Finance and Accounting*, 8(8), 121-127.
- Franco, M., Santos, M. F., & Ramalho, I. (2014). An exploratory study of entrepreneurial marketing in SMEs: The role of the founder-entrepreneur. *Journal of Small Business and Enterprise Development*, 21(2), 265-283.
- George, S., Yanquig, L., Anne-Maries, M., & Jared, M. H. (2017). Industry characteristics, stages of e-commerce communications and entrepreneurs and SMEs revenue growth. *Technological Forecasting & Social Change*. Elsevier.

- Ghobakhloo, M., & Tang, S. H. (2013). The role of Owner/Manager in adoption of electronic commerce in small Business. The case of developing countries. *Journal of small business and enterprise Development*, 20(4), 754-787.
- Ghobakhloo, M., Sabouri, M. S., Hong, T. S., & Zulkifli, N. (2011). Information technology adoption in small and medium-sized enterprises: An appraisal of two decades' literature. *Interdisciplinary Journal of Research in Business*, 1(7), 53-80.
- Gupta, R., & Naqvi, S. K. (2014). A framework for applying critical success factors to ERP
- Higon, D. A. (2011). The impact of ICT on innovation activities: Evidence for UK SMEs. *International Small Business Journal*, 30(6), 364-699.
- Ioannis, G., Alexandra, K., Efthymia, K., & Aggelos, T. (2017). What drives ICT adoption by SMEs? Evidence from a large-scale survey in Greece. *Journal of Business Research*.
- Irefin, I. A., Abdul-Azeez, I. A., & Tijani, A. A. (2012). An investigative study of the factors affecting the adoption of information and communication technology in small and medium scale enterprises in Nigeria. *Australian Journal of Business and Management Research*, 2(2), 1-9.
- Jones, P., Packham, G., & Beckinsale, M. (2013). SMEs adoption of enterprise applications: A technology-organization-environment model. *Journal of Small Business and Enterprise Development*, 20(4), 735-753.
- Kasekende, L., & Opondo, H. (2003). Financing Small and Medium – scale enterprises (SMEs): Uganda's Experience. *Bank of Uganda working paper*.
- Khalifa, A. (2016). Determinants of information and communication technologies adoption by Tunisian firms. *Journal of innovation Economics and Management*, 20(2).
- Kumar, R., Singh, R. K., & Shandar, R. (2016). Study on collaboration and information sharing Practices for SCM in Indian SME. *International Journal of Business Information Systems*.
- Lecic-Cvetkovic, D., Omerbegovic-Bijelovic, Zoric, S., & Janicic, R. (2015). *E-Banking application in business companies- a case of Serbia*. Inf. Dev.
- Lee, S., Park, G., Yoon, B., & Park, J. (2010). Open innovation in SMEs- an intermediated network model. *Research policy*, 39(2), 290-300.
- Maldonado, G. G., Sanchez, G. J., Gaytan, C. J., & Garcia. (2012). Measuring the competitiveness level in furniture SME of Spain. *International Journal of Economics and Management Sciences*, 1(11), 9-19.



- Modinmogale, L., & Kroeze, J. (2011). The role of ICT within Small and Medium Enterprises in Gauteng. *Communications of the IBIMA*, 1-13.
- Mohammadi, F., & Abrizah, A. (2013). *Information quality problems in Farsi Web-based learning resources: How do teachers assure of the content quality for classroom use?* Inf. Dev.
- Mokaya, S. O. (2012). The adoption of information and communication technology by small enterprises In Thika. *International Journal of Business and Social Science*, 3(13).
- Mutesigensi, D., Eton, M., Ebong, C. D., & Mwosi, F. (2017). Cash flow and survival of SMEs in Arua District, West Nile Region Uganda. *International Journal of Small Business and Entrepreneurship Research*, 5(5), 9-18.
- Nazir, A. M. & Zhu, X. (2018). E-Commerce adoption factors affecting the SMEs: A case study investigation of a developing economy - Pakistan. *British Academy of management (BAM) BAM 2018 conference proceeding*.
- OECD. (2017). *Enhancing the contributions of SMEs in a global and digitalized economy*.
- Okello-Obura, C. (2011). Okello-Obura, C. (2011). Utilization of ICTs by SMEs in record and information management in Uganda: A baseline study. *SA Archives Journal*, 1.
- Okello-Obura, C. (2011). Records and information management practices among SMEs in Tororo district, Uganda. *Library Review*, 61(6), 447-469.
- Olise, M., Anigbogu, T., Edoko, T., & Okoli, M. (2014). Determinants of ICT adoption for improved SME's performance in Anambra state , Nigeria. *American International Journal of Contemporary Research*, 4(7), 163-176.
- Oliviera, T., & Martins, M. F. (2011). Literature review of information technology adoption models at firm level. *The electronic journal information system evaluation*, 14(1), 110-121.
- Ollo-Lopez, A., & Aramendia-Muneta, M. E. (2012). ICT impact on competitive, Innovation and environment. *Telematics and Informatics*, 29, 204-210. *Telematics and Informatics*, 29, 204-210.
- Ongori, H., & Migiro, S. O. (2010). Ongori, H., & Migiro, S.O (2010). Information and Communication technologies adoption in SMEs: Literature review. *Journal of Chinese Entrepreneurship*, 2(1), 93-104.
- Ovia, J. (2005). Enhancing the Efficiency of the Payment system in Nigeria . *CBN Bullion* , 29(1), 8- 18.
- Polasik, M., & Wisniewski, T. P. (2008). Empirical analysis of internet banking adoption in Poland, *IJBM*, 27(1), pp. 32-52.

- Rakibul, H., Abu-Naser, M. S., Adnan, M. A., & Yukun, B. (2015). Adoption of information and communication technology for development: A case study of small and medium enterprises in Bangladesh. *Information Development*, 32(4), 986-1000.
- Ramayah, T., Niu, S. L., Seyedeh, K. T., & Syed, A. R. (2016). Factors influencing SMEs Website Continuance Intention in Malaysia. *Telematic and informatics*, 33(2016), 150-164.
- Sekaran, U. (2006). *Research Methods for Business. A Skill Building Approach 4th Ed.* UNECA .
- Sempala, R., & Mukoki, J. (2018). Determinants of growth of micro, small and medium enterprises in developing countries. Evidence from Rubaga Division, Kampala District Uganda. *SSRN Electronic Journal*.
- Steinfeld, C., LaRose, R., Chew, H. E., & Tong, S. T. (2012). Small and Medium Sized enterprises in rural business Clusters: The relation between ICT adoption and benefits derived from cluster membership. *The information Society*, 28, 110-120.
- Tan, K. S., Chong, S. C., Lin, B., & Eza, U. C. (2010). Internet –based ICT adoption among SMEs: Demographic versus benefits, barriers and adoption intention. *Journal of Enterprise Information Management*, 23(1), 27-55.
- Uganda Bureau of Statistics (UBOS). (2003). *Uganda Bureau of Statistics (UBOS) (2003). A report on the Uganda Business Register, 2001/2002.* Uganda Bureau of Statistics.
- Urban, B., & Naidoo, R. (2012). Business Sustainability: empirical evidence on operational Skills in SMEs in South Africa. *Journal of Small Business and Enterprise Development*, 19(1), 146- 163.
- Yeboah, A. M. (2015). Determinants of SME Growth: An Empirical Perspective of SMEs in the Cape Coast Metropolis, Ghana. *The Journal of Business in Developing Nations*, 14.



## Intellectual Capital and Financial Performance of Deposit Money Banks in Nigeria

<sup>1</sup>Adewumi, Ademola Adeniran and <sup>2</sup>Adesina, Olufemi Dadebo  
<sup>1&2</sup>Department of Accountancy, Federal Polytechnic Ile-Oluji, Ondo State

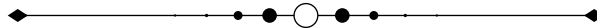

### *Abstract*

**T**he study examines the impact of Intellectual capital on financial performance of Deposit Money Banks in Nigeria. Specifically, the result examines the effect of Value Added Human Capital, Structural Capital and Value Added Capital Employed on Return on Asset of Deposit Money Banks in Nigeria. The study employed a longitudinal research design. However, a sample of 8 banks was used in this study and the selection was done using the convenience sampling procedure. The study made use of secondary data from the annual reports of the sampled quoted companies on the Nigerian Stock Exchange for the period 2012-2018. The data estimation technique made use of panel regression. Our findings reveal that (i). Value Added Human Capital has a significant effect on Return on Assets of Deposit Money Banks in Nigeria. (ii). Value Added Capital Employed has a significant effect on Return on Assets of Deposit Money Banks in Nigeria and (iii). Structural Capital Value Added has a significant effect on Return on Asset of Deposit Money Banks in Nigeria. In view of the study findings, the key recommendation of the study is the need for companies to pay more attention to human and intellectual capital. A situation where human and intellectual capital is not being recognized in the financial statement is a huge anomaly given the critical role it plays in corporate performance.

**Keywords:** Intellectual capital, Financial performance, Deposit money banks

---

## **Introduction**

Intellectual assets, or a company's unique collection of know-how, skills, values, and processes, have surpassed tangible resources like land, machinery, and cash as the dominant "economic wealth creation element" in contemporary economies (Adegbayibi, 2021). Intellectual capital refers to intangible assets like knowledge or ideas that may be turned into cash (IC). This definition covers a wide swath of territory, from in-house expertise to data that stays with the company even after personnel leave. With its central role in today's economy, IC is crucial to maintaining high levels of performance and gaining an edge in the marketplace (Adegbayibi, 2021). Owning strategic resources, particularly intangible ones, and making optimal use of these resources is essential for gaining a competitive edge and achieving high levels of performance, as stated by the resource-based perspective (Ahmad & Bin, 2019). Both material and intangible assets may play a role as strategic resources. If you want to stay competitive and perform at a high level, you need resources that are precious, rare, non-transferable, unique, and irreplaceable. In the literature, IC is given all the characteristics that are often associated with strategic resources (Ahmed, Guozhu, Mubarik, Khan & Khan, 2019). Since IC is a strategic intangible asset, there should be a correlation between it and the company's overall success (Bayraktaroglu, Calisir and Baskak, 2019). In other words, if IC is a resource that gives the company an edge in the marketplace, it should also improve the bottom line. While the term "intellectual capital" has not been formally defined, it is generally agreed that it is a broader expansion of the conventional idea of capital that encompasses intangible resources that may provide economic value and boost an organization's development and financial performance (Battisti, et. al, 2021). Since IC has been shown to improve both performance and competitiveness, it is essential that it be managed properly

Although intellectual capital's significance has theoretical backing, there has been some inconsistency. The effects of IC on business success have been studied before, and researchers have discovered some interesting conclusions. Several previous research (Asif, Ting, & Kweh 2020; Soetanto & Liem 2019; Singla 2020; D'enopoljac et al. 2016; Nadeem et al. 2018) demonstrated a favourable correlation between intellectual capital and business success. However, some studies have shown that intellectual capital has a negative correlation with company success (Hamdan, 2018; Hamdan, Buallay & Alareeni 2017; Haris, Yao, Tariq, Malik, & Javaid 2019; Soewarno & Tjahjadi, 2020). According to Kamukama et al. (2010), the fact that this field of study is still in its infancy in terms of the use of empirical methods, are to blame for the conflicting findings. This suggests the need to investigate more econometric methods for evaluating the connection between the variables, and this work adds to the existing literature in this area. The study therefore examines the impact of intellectual capital on firm performance in Nigerian deposit Banks. The study is divided into the following areas. The literature review and theoretical framework is presented in section 2. Section 3 then details the technique and model formulation. Section 4 presents and discusses the findings, while Section 5 offers a summary and conclusions.

## **Literature Review**

The purpose of the research conducted by Hanady, Sinan, Enas, & Amneh (2022) is to look at how different types of intellectual capital affect business performance and how family management might play a mediating function in this context. Structural equation modelling is used to evaluate the assumptions for a group of 46 publicly traded Jordanian service companies throughout the period of 2014-2019. The findings show that an organization's ability to effectively use its intellectual capital is a major contributor to its success in increasing

both its financial performance and its market value. Increasing a company's human capital efficiency may have a significant beneficial impact on its bottom line, as measured by metrics like return on assets and earnings per share. There is no evidence to suggest that family management acts as a mediator between intellectual capital and corporate performance. Ali, Murtaza, Hedvicakova, Jiang, Naeem (2022) research looks at the financial performance of listed Pakistani and Indian firms from 2010 to 2020 to see whether there is any correlation between IC efficiency and financial performance. STATA is used for doing regression analysis. Human Capital (HC), Structural Capital (SC), and Capital Employed (CE) were shown to have a substantial effect on the financial performance of businesses in Pakistan and India. These results are consistent with resource-based theory (RBT). The results should serve as a wake-up call for management to prioritise IC and boost financial results.

Using the Value Added Intellectual Capital (VAIC) approach, Xu and Li (2019) analysed data from a sample of 29 Chinese and 20 Pakistani banks between 2010 and 2019 to estimate the impact of IC on banks' bottom lines. The results indicated that the IC of banks in both nations has a beneficial effect on their financial performance, while the CEE of banks had the greatest effect. Profitability in the Chinese banking industry is driven by SCE, but in Pakistan it is driven by HCE. A bank's bottom line may benefit from implementing a lagged IC strategy. Increasing IC investment is necessary to boost bank performance in rising Asian economies. Between 2009 and 2011, Shumaila and Afza (2014) analysed the correlation between IC and company success. The researchers employed the Hausman test, a fixed-effect model, and correlation to analyse data from one hundred different textile and chemical firms. They discovered that HCE, CEE, and SCE—the building blocks of IC—all had a beneficial effect on a business' bottom line. Using data from the Ho Chi Minh Stock Exchange, Tran, Dinh, Hoang, and Vo (2022) analyse the impact of intellectual capital and CSR on business performance in Vietnam from 2011 to 2020. The technique of moments in its generalised form is used. We discover the existence of both individual and combined influences. In addition, our findings indicate that the two most important forms of intellectual capital that influence company performance are structural capital efficiency and capital employed efficiency. Our research also confirms the synergistic benefits of intellectual capital and CSR on business outcomes. These results provide new insight into the potential for management initiatives to boost business performance in Vietnam, particularly those that focus on intellectual capital and corporate social activities.

The purpose of Mohammad's (2022) research is to identify the relationship between Jordanian industrial listed businesses' intellectual capital (IC) and their financial performance. The VAIC model (value-added intellectual coefficient) will be used to quantify IC, and the ROE (return on equity) will be used to evaluate business success (ROE). To investigate the effect of leverage in the connection between IC and ROE, we add financial leverage as a control variable in the primary model. The incremental information content for IC components in explaining the shift in business performance is also explored in this research. Furthermore, the size impact is investigated to reveal whether the nexus between ROE and IC varies depending on the size of the firm. The research population consists of 77 Jordanian manufacturing enterprises and 788 company-year data from 2006 to 2020. The research found that industrial business performance is significantly affected by intellectual capital. In particular, structural Capital Efficiency (SCE) has a negative effect on business performance, whereas Human Capital Efficiency (HCE) and Capital Employed Efficiency (CEE) both positively affect return on equity (ROE). The impact of IC on the productivity was



studied by Ali and Anwar (2021). Human capital was shown to have the strongest correlation with the entity's performance, whereas ownership as an intellectual capital factor had the worst correlation. Lu et al. (2021) set out to investigate the connection between IC and business results and found that it has no impact on revenue growth but reduces a company's market value. The research also found that IC contributed to increased corporate return, profitability, productivity, and revenue for participating businesses. The impact of intellectual capital on firm performance was studied by Tarigan et al. (2019), who looked specifically at productivity and profitability. According to the data given, the link between a company's intellectual capital and its market value is weak, while the link between intellectual capital and financial performance is strong.

### **Theoretical Framework: Resources Based View Theory**

In this investigation, we make use of RBT, which is one widely-held hypothesis. Wernerfelt (1984), the theorist responsible for formalising this idea, said that "to the company, resources and products are the two sides of the coin." RBT asserts that it can guide the business to better long-term success and that it has the resources to fulfil its goals. It is possible to focus valuable and limited assets in order to accomplish aims. It has been said that "resources are the physical and intangible assets organisations utilise to design and execute policies" (Barney & Arian, 2001). The concepts of resource heterogeneity (diversity) and resource immobility are central to this framework (Nothnagel, 2008). When discussing the relationship between IC and business success, RBT is an acceptable framework to use (Kristandl & Bontis, 2007). Each company has its own unique set of intangible resources, such as expertise, experience, values, and solutions (Pulic & Kolakovic, 2003). To some extent, intangible resource management may aid in the attainment of business goals, the enhancement of productivity, and the growth of market value. In examining the connection between the two assumption resources in RBT, Pulic and Kolakovic's (2003) thesis is congruent with the logic of Barney and Arian (2001).

### **Methodology**

The study employed a longitudinal research design. A longitudinal design involves repeated observations of the same variables over long periods of time unlike the cross-sectional design which examines variables at a point in time. As a result, they can establish sequences of events. The choice of the design is because the nature of the variables especially the data for the study involves repeated observations of the same variables over periods. Hence the design is suitable for this study. The population of the study comprises of all listed money deposit banks manufacturing companies on the Nigerian stock exchange. As at December 2021, there are about 15 deposit money banks (NSE, Fact Book, 2021) covering the study period. However, a sample of 8 banks was used in this study and the selection was done using the convenience sampling procedure. Secondary data was used for this study. The data was retrieved from corporate annual reports of the sampled quoted companies on the Nigerian Stock Exchange for the period 2012-2021 financial years. The researcher utilized only corporate annual reports because they are readily available, accessible and also provide a greater potential for comparability of results. Panel data regression is used in the analysis of the data.

### **Model Specification**

The model for the study examines the impact of Intellectual capital (IC) on corporate firm performance (CFP). The model for the study adapts those of  
Hence the functional model below

$$CFP=f(IC) \text{-----} (i)$$

Where CFP= Corporate financial performance

IC= Intellectual capital

Decomposing the variables into their measures and specifying the econometric form and including control variables of firm size we have;

$$ROE_{it} = \lambda_0 + \lambda_1 SCAP_{it} + \lambda_2 VACE_{it} + \lambda_3 VAHC_{it} + \lambda_4 FSIZE_{it} + u_{it} \text{-----} (ii)$$

Where;

ROE= Return on equity measured as ratio of Profit after tax to total equity

SCAP= Structural capital measured as the difference between profit after tax (other than employee expenses) and employee expenses incurred

VACE= Value added capital employed measured as the ratio of profit after tax to capital employed or equity

VAHC= Value added human capital measured as the ratio of profit after tax to human capital expenditures

FSIZE= Firm size measured as the log of total assets

### Presentation and Analysis of Result

**Table 1: Descriptive Statistics**

	Mean	Median	Maximum	Minimum	Std. Dev.	Jarque-Bera	Probability
SCAP	28646668	1871121	7.31E+08	0.00.	85906526	11647.12	0.000
VACE		0.428571	0.714286	0.428571	0.066605	274.1904	0.00
VAHC	0.087931	0.1	0.62	0.38	0.094671	26.06121	0.000
ROE	5.502414	3.75	53.96	-17.18	8.416129	1620.177	0.000
FSIZE	7.019693	7.01	8.68	5.38	0.635391	1.284116	0.5262

**Source:** Researchers compilation (2022).

The descriptive statistics is presented in table 1 and as observed, the mean for structural capital stood at 2864668mn. The standard deviation if 85906526 is very large which indicates that SCAP varies considerably from one firm to another and this is despite the fact that all firms are in the financial services industry. The mean for value added capital employed (VACE) stood at 0.4605 with maximum and minimum values of 0.714 and 0.4285 respectively. The standard deviation of 0.066 is low and indicates less variability and volatility in VACE across time for the sampled banks. The mean for value added human capital (VAHC) stood at 0.0879 with maximum and minimum values of 0.62 and 0.38 respectively. The standard deviation of 0.0947 is low and indicates less variability and volatility in VAHC for the cross-sections. The mean for ROE stood at 5.502% with a standard deviation of 8.416. The maximum and minimum values stood at 53.96% and -17.18% respectively. Looking at the control variables, the mean for firm size (FSIZE) measured as the log of total assets stood at 7.019 with a standard deviation of 0.063. The maximum and minimum values stood at 8.68 and 5.38 respectively.



**Table 2: Pearson Correlation Matrix**

	SCAP	VACE	VAHC	FSIZE	ROE
SCAP	1				
VACE	0.0928	1			
p-value	0.135				
VAHC	0.0598	0.3593	1		
p-value	0.336	0.00*			
FSIZE	0.0488	-0.101	-0.062	1	
p-value	0.4326	0.1042	0.3167		
ROE	0.0504	0.0923**	0.012	-0.198	1
p-value	0.4178	0.137	0.8429	0.0013*	

Source: Researchers compilation (2022).

Table 2 shows the correlation statistics for the variables and the focus for the study is the correlations between the financial performance measured by Return on equity (ROE) and the independent variables. The results reveals that ROE is positively correlated with SCAP( $r=0.0504$ ) but not significant at 5% ( $p=0.4178$ ), positively correlated with VACE ( $r=0.0923$ ) and significant at 10% ( $p=0.0923$ ). In addition, the result shows that ROE is also positively correlated with VAHC ( $r=0.012$ ) though not significant at 5% ( $p=0.8429$ ).

**Table 3 Variance Inflation Factor (VIF) Test**

Variable	VIF
SCAP	1.708
VACE	3.13
VAHC	2.207
FSIZE	2.14

Source: Researcher’s compilation (2018)

The VIF values for all the independent variables are all less than 10 which is the threshold VIF value. Hence, we can conclude that there is the absence of multicollinearity in between the independent variables and as such the estimated regression results will yield non-biased estimates of the coefficients.

**Table 4. Regression Result**

Variable	Aprori sign	FE-estimates Coefficient ( ) standard error { } p-values	RE-estimates Coefficient ( ) standard error { } p-values
C		0.0469* (0.0227) {0.0395}	0.0395 (0.033) {0.2358}
SCAP	+	-0.0617* (0.0142) {0.000}	0.0183 (0.0620) {0.7670}
VACE	+	0.0298* (0.0146) {0.0408}	0.0082 (0.0352) {0.8156}
VAHC	+	0.0415* (0.0112) {0.000}	0.1338** (0.0764) {0.0803}
FSIZE	+	-0.0751* (0.0079) {0.000}	-0.1013* (0.0162) {0.0000}

Model Parameters			
R <sup>2</sup>		0.641	0.085
Adjusted R <sup>2</sup>		0.533	0.076
F-statistic		28.982	11.032
Prob(F-stat)		0.000	0.000
Durbin-Watson		1.93	1.46
Model Diagnostics			
$\chi^2_{\text{Hetero}}$			(0.284)
$\chi^2_{\text{Serial/Corr}}$			(0.381)
$\chi^2_{\text{Norm}}$			(0.670)
$\chi^2_{\text{Hausman}}$			(0.00)

**Source:** Researcher's compilation (2022)

Table 5 examines the estimation results for the impact of Intellectual capital on financial performance of Deposit Money Banks in Nigeria. Specifically, the result examine the effect of Value Added Human Capital, Structural Capital and Value Added capital employed on Return on Asset of Deposit Money Banks in Nigeria. The Hausman test statistic with p-value = 0.000 confirms the superiority of the fixed effects estimations over the random effects. The R<sup>2</sup> for the model stood at 64.1% with an adjusted value of 53.3%. The F-stat of 28.982 (p-value = 0.00) is significant at 5%. The analysis of coefficients reveals that value added human capital (VAHC) has a positive effect (0.0415) on firm financial performance and also statistically significant (p=0.000) at 5%. Hence the null hypothesis that Value Added Human Capital has no significant effect on Return on Assets of Deposit Money Banks in Nigeria is rejected.

From table 4., the analysis of coefficients reveals that structural capital (SCAP) estimated in its log form, has the expected positive effect (0.0617) effect on financial performance and statistically significant at 5% (p=0.000). The result thus confirms that increase in structural capital can improve the financial performance significantly. Therefore, the null hypothesis that Structural Capital Value Added has no significant effect on Return on Asset of Deposit Money Banks in Nigeria is rejected. The effect of value added capital employed (VACE) is also positive (0.0298) and is statistically significant at 5% (p=0.0408). The result indicates that an increase in the valued added capital employed will significantly increase firm financial performance. Therefore, the null hypothesis that Value Added Capital Employed has no significant effect on Return on Asset of Deposit Money Banks in Nigeria is rejected. Based on the regression analysis showing the impact of intellectual capital variables on performance of deposit money banks in Nigeria, the results show there is a positive relationship between intellectual capital measures (VACE, VAHC and SCAP) and firm performance. The findings of the study corroborates those of Hanady, Sinan, Enas and Amneh (2022), Ali, etal (2022), Xu and Li (2019) wAfza (2014), Tran, Dinh, Hoang and Vo (2022) and Mohammad (2022) On the contrary, studies (Lu et al. 2021, Hamdan, Buallay and Alareeni 2017; Haris, Yao, Tariq, Malik, and Javaid 2019; Soewarno and Tjahjadi, 2020) found a negative relationship between intellectual capital and firm performance.

### Conclusion and Recommendations

Intellectual capital is one of the human capital assets that boost banks efficiency and financial performance hence an inefficient intellectual capital would decrease banks' financial performance. Our findings reveal that (i). Value Added Human Capital has a significant effect on Return on Assets of Deposit Money Banks in Nigeria. (ii). Value Added Capital Employed has a significant effect on Return on Assets of Deposit Money Banks in Nigeria and (iii).

Structural Capital Value Added has a significant effect on Return on Asset of Deposit Money Banks in Nigeria. In view of the study findings, the key recommendation of the study is the need for companies to pay more attention to human and intellectual capital. A situation where human and intellectual capital is not being recognized in the financial statement is a huge anomaly given the critical role it plays in corporate performance. Intellectual capital plays a significant role for value creation in today's economies and organizations, where organizations in knowledge-based economies have been depending on knowledge assets rather than tangible assets to enhance its competitive advantages.

## References

- Adegbayibi, A. T. (2021). Intellectual capital and firm performance of listed firms in Nigeria: Moderating role of corporate governance. *Jurnal Akuntansi Dan Auditing*, 17(2), 33–46.
- Ahmad, M., & Ahmed, N. (2016). Testing the relationship between intellectual capital and a firm's performance: an empirical investigation regarding financial industries of Pakistan. *Int. J. Learn. Intellect. Cap.* 13(3)250–272. doi: 10.1504/IJLIC.2016.075691
- Ahmad, R., & Bin, M. H. (2019). Exploring the relationship of intellectual capital, board characteristics and business performance: a literature review. *Pakistan Journal of Human. Soc. Sci.* 7(2) 185–202. doi: 10.52131/pjhss.2019.0702.0080
- Ahmed, S. S., Guozhu, J., Mubarik, S., Khan, M., & Khan, E. (2019). Intellectual capital and business performance: The role of dimensions of absorptive capacity. *J. Intellect. Capital*, 21, 23–39. doi: 10.1108/JIC-11-2018-0199.
- Ali, S., Murtaza, G., Hedvicakova, M., Jiang, J. & Naeem, M. (2022). Intellectual capital and financial performance: A comparative study. *Frontiers in Psychology*, 6(1), 23-43.
- Ali, B. J., & Anwar, G. (2021). Intellectual capital: A modern model to measure the value creation in a business. *International Journal of Engineering, Business and Management*, 5(2), 31-43.
- Asif, J., Ting, I. W. K., & Kweh, Q. L. (2020). Intellectual capital investment and firm performance of the Malaysian energy sector: A new perspective from a non-linearity test. *Energy Res. Lett.* 1(2)13-22. doi: 10.46557/001c.13622
- Barney, J. B. & Arikan A. M. (2001). *The resource-based view: Origins and implications in The Blackwell Handbook of Strategic Management*. Oxford: Blackwell Publishers
- Battisti, E., Nirino, N., Christofi, M., & Vrontis, D. (2021). Intellectual capital and dividend policy: The effect of CEO characteristics. *J. Intellect. Cap.* 23, 127–143. doi: 10.1108/JIC-11-2020-0354

- Bayraktaroglu, A. E., Calisir, F., & Baskak, M. (2019). Intellectual capital and firm performance: An extended VAIC model. *Journal of Intellect Capital*, 20(2) 406–425. doi: 10.1108/JIC-12-2017-0184
- Hamdan, A. (2018). Intellectual capital and firm performance: Differentiating between accounting-based and market-based performance. *Int. J. Islam. Middle East. Financ. Manag.* 11(2) 139–151. doi: 10.1108/IMEFM-02-2017-0053
- Hamdan, A. M., Buallay, A. M., & Alareeni, B. A. (2017). The moderating role of corporate governance on the relationship between intellectual capital efficiency and firm's performance: Evidence from Saudi Arabia. *Int. J. Learn. Intellect. Cap.* 14(2) 295–318. doi: 10.1504/IJLIC.2017.087377
- Haris, M., Yao, H., Tariq, G., Malik, A., & Javaid, H. M. (2019). Intellectual capital performance and profitability of banks: evidence from Pakistan. *Journal of Risk Fin.Manag.* 12(2), 6-39.
- Jabbar, Shumaila & Afza, Talat. (2014). Relationship between intellectual capital and financial performance of Pakistani non-financial firms. A comparative study of textile and chemical industry. *International Interdisciplinary Research Journal*, 3(2) 67-80.
- Khan, S. Z., Yang, Q., & Waheed, A. (2019). Investment in intangible resources and capabilities spurs sustainable competitive advantage and firm performance. *Corp. Soc. Respon. Environ. Manag.*, 26(2) 285–295. doi: 10.1002/csr.1678.
- Kristandl G., & Bontis N. (2007). Constructing a definition for intangibles using the resource based view of the firm. *Manag. Decis.*, 45(1), 1510–1524.
- Lu, Y., Li, G., Luo, Z., Anwar, M., & Zhang, Y. (2021). Does intellectual capital spur sustainable competitive advantage and sustainable growth? A study of Chinese and Pakistani firms. *Sage Open*, 11(1). <https://doi.org/10.1080/09537325.2020.1862414>
- Mohammad, F. (2022). Intellectual capital components and industrial firm's performance. *Problems and Perspectives in Management*, 20(1), 554-563.
- Rochmadhona, B. N., Suganda, T. R. & Cahyadi, S. (2018). The competitive advantage between intellectual capital and financial performance of banking sector in ASEAN. *Jurnal keuangan dan Perbankan* 22, 321–334.
- Soewarno, N. & Tjahjadi, B. (2020). Eco-oriented culture and financial performance: roles of innovation strategy and eco-oriented continuous improvement in manufacturing state-owned enterprises, Indonesia. *Entrepreneurship and Sustainability Issues*, 8(1) 341-359.
- Tarigan, J., Listijabudhi, S., Hatane, S. E. & Widjaja, D. C. (2019). The impacts of Intellectual Capital and Financial Performance: An Evidence from Indonesian Manufacturing industry. *Indonesian Journal of Business and Entrepreneurship*, 5(1), 65 76.



## Entrepreneurial Culture a Way Out of Unemployment in Nigeria (A Study of Ondo State)

**Kazeem Toyin Cynthia, Omula Godwin G.  
& Adewale Adeola Oluyemisi**

<sup>1&3</sup> Department of Business Administration and Management  
Federal Polytechnic Ile-oluji, Ondo State, Nigeria  
<sup>2</sup> Department of Accountancy  
Federal Polytechnic Ile-oluji, Ondo State, Nigeria

---

### **Abstract**

**T**his study examines entrepreneurial culture as a way out of unemployment among the youth in Nigeria (A study of Ondo State) and the specific objectives of the study are to examine the extent to which exposure to technical knowledge influence the job creation among youth in Ondo State as well as evaluate the extent to which exposure to occupational experience affect job creation among youth in Ondo State. A survey research design was used for this study and according to Ondo State profile, the population of Ondo State is 3,460,877. The random sampling technique was adopted for the study to select 10 respondents from each of the 18 local government areas in Ondo state. Therefore, the sample size for this study was 180 respondents in Ondo State. The test of hypotheses was analyzed using Chi - square to test the Hypotheses at 5% level of significance. A total of 180 copies of questionnaire were administered to the respondents and 168 the copies of questionnaire were retrieved completely. The finding of the study revealed that entrepreneurial culture contributed to setting up of small business among the youth in Ondo State. The study also discovered that entrepreneurial culture led to exposures to technical knowledge and occupational experience among youths in Ondo State. The study concluded that exposures to technical knowledge ( $\chi_{cal}$ )  $35.071 > (\chi_{tab}) 9.49$  has positive relationship on job creation as well as occupational experience ( $\chi_{cal}$ )  $51.416 > (\chi_{tab}) 9.49$  has positive and significant relationship on reducing the level of unemployment among youth in Ondo State. The study recommended that there is need to formulate policy to enforced implementation of entrepreneurial culture so as to expand business operations in Nigeria.

**Keywords:** Entrepreneurial culture, Way out, Unemployment, Nigeria

---



## **Introduction**

Unemployment has been a critical issue facing Nigeria for over two decades. Olusakin, (2010) stated that even though up-to date statistical data are lacking, local media reports indicate that half of the Nigerian population of 148 million are youths, 95% of whom are unemployed. Decades of economic stagnation and poverty have driven a large percentage of this figure to crime and violence in their early years. The youths, when they are not gainfully employed either in the public or private sector of the economy, become very vulnerable to criminality such as kidnapping, rape, armed robbery and many other social vices which are now a menace to the society (Nwachukwu & Nwamuo, 2010). The Federal and state governments have made several efforts through some agencies to address the issue, yet many young graduates are unemployed either in the public or private sector of the economy. Some of these young people are also unable to gain admission into the tertiary institutions and as a result, are neither at work nor in school. Therefore, they have no option than to roam about the streets in search of vanity. As indicated by statistics, Youth unemployment in Nigeria is observed to be on the increase, and various efforts seem not to be yielding significant results (Aina, Abdulrahman & Abdulwasiu, 2019). According to the National Bureau of Statistics (2020), Nigeria's unemployment and underemployment rates are a combined of 55.7% at the end of the 2nd quarter in the Year 2020 (National Bureau of Statistics (2020)). Nigeria has the highest population in Africa, with a population of about 177 million people and about 70% are Youth. Nigeria is blessed with mineral resources, agricultural products, and human resources. After 60 years of independence, Nigeria's economy is still monolithic, depending on oil as a significant revenue source. Nigeria is a paradoxical nation, blessed with enormous resources but confronted with high unemployment (Mba & Godday, 2104). Traditional career paths and opportunities are fast disappearing (Usmam, Waziri, Abdullahi, & Babayo, 2018).

Entrepreneurship is essential to any economy globally; entrepreneurship is considered the economic backbone necessary for job creations, economic growth, poverty alleviation, and reduction. Entrepreneurship activities can stimulate economic growth and innovation capacity in a country. Entrepreneurship is now more recognized as a significant component of economic growth, employment generation, and innovation. There is a strong positive correlation between entrepreneurship and economic development (Usioboh, 2008). An entrepreneur is regarded as an economic agent who can perceive market opportunities and assemble the needed factors of production to exploit specific opportunities (Aardt, Van Aardt, Bezuidenhout & Mumba, (2008). According to Andretsch, Grilo & Thunik (2007), governments of the countries to create jobs, economic, and the provision of a solution to social issues focus on entrepreneurial development. Countries that promote entrepreneurship by providing the right environment are well-positioned to deepen globalization (White & Kenyon, 2000). Entrepreneurship is the bedrock of several economies that are doing well in the world. The study of young individuals and the involvement in entrepreneurial activities is increasingly gaining relevance due to the economic downturn of recent years (Minola, Criaco&Obschonka, 2016; Brixiová, Ncube & Bicaba, 2014).Entrepreneurship is a phenomenon that brings assistance to Youth and society at large. Entrepreneurship history and development in Nigeria dates way back to the 1960s (Ekanem, 2015).

Entrepreneurial culture is a condition in which new ideas and creativity are expected, taking risks are encouraged, failure is tolerated, learning is encouraged, innovations about product, process and management are defended and a continuous change is accepted as the carrier of opportunities (Foss & Lyngsie, 2011). In broader conceptual models, entrepreneurial culture

has also been identified as a necessary component of a firm's architecture in order to successfully pursue an entrepreneurial strategy that is, engaging in opportunity-seeking and advantage-seeking activities (Ireland, Hitt, & Sirmon, 2003). There has also been little exploration of the relationship between the entrepreneurial culture concept and the firms that are supposed to demonstrate this phenomenon. In particular, it is unclear which firms possess an entrepreneurial culture and to what degree they possess it. The importance of entrepreneurship to economic development has been highlighted by many researchers (Davidsson, Delmar, & Wiklund, 2006) and it is now well-recognized that education and training opportunities play a critical role in cultivating future entrepreneurs and in developing the abilities of existing entrepreneurs to grow their business to greater levels of success (Henry, Hill, & Leitch, 2003).

### **Statement of the Problem**

According to Ogunbanjo, Afolabi, Aninkan, Ogunsola, & Orobiyi (2017), unemployment was not a serious problem in Nigeria before and after the civil war 1967-1970. However, the education of entrepreneurship course has remained at best theoretical demonstration of course materials and concepts, with little or no emphasis on practical aspects. Even at that, the requisite manpower, funding, learning environment and infrastructure needed to create and develop entrepreneurship culture through this course are lacking. There is no technical knowledge, occupational experience and success stories of entrepreneurs that can motivate youth to imbibe entrepreneurial culture as they grow. These could be one of the reasons for hundreds of thousands of university graduates remaining jobless many years after their graduation. While studies have been carried out on entrepreneurship behaviours or attitudes and job creation or self-reliance among students, none has been specifically targeted at entrepreneurship culture among as a way out of unemployment among the youth in Nigeria. For that reason, this study aims to establish the existence of entrepreneurial culture as a way out of unemployment among the youth in Nigeria (A study of Ondo State).

### **Research Questions**

The study is guided by the following questions:

- i. To what extent does exposure to technical knowledge influence the job creation among youth in Ondo State?
- ii. To what extent does exposure to occupational experience affect job creation among youth in Ondo State?

### **Objective of the Study**

The main objective of the study is to examine entrepreneurial culture as a way out of unemployment among the youth in Nigeria (A study of Ondo State). Specific objectives of the study are to;

- i. examine the extent to which exposure to technical knowledge influence the job creation among youth in Ondo State
- ii. evaluate the extent to exposure to occupational experience affect job creation among youth in Ondo State

### **Research Hypotheses**

The following null hypotheses are formulated for the study:

**H<sub>01</sub>:** There is no significant relationship between exposure to technical knowledge and job creation among youth in Ondo State



**H<sub>o2</sub>:** There is no significant relationship between exposure to occupational experience and job creation among youth in Ondo State

**H<sub>o3</sub>:** There is no significant relationship between risk taking and level of unemployment among youth in Ondo State

### **Significance of the Study**

The findings of this study were significant to entrepreneurs in establishing the relationship that exists between entrepreneurial culture and unemployment among the youth in Nigeria. Specifically, the findings of this study shed light on the influence of entrepreneurial culture and on performance of organization. This study also helps in the formulation of policies to improve on entrepreneurship culture and also enhances the creation of more theories in the area of entrepreneurship orientation and its economic significance. The finding of the study was significant to SMEDAN and Ministry of commerce and industry as they are mandated with economic planning by highlighting the need to assess the influence of key pillars to the success of entrepreneurial activities.

### **Scope of the Study**

This study examined the entrepreneurial culture as a way out of unemployment among the youth in Nigeria. The choice of this state was in view that the state is one of highest unemployment level in South-West, Nigeria and because of its closeness to the researcher. The targeted respondents of the study are youth in Ondo State. The study covered measures of entrepreneurial culture and how it affects the youth unemployment rate in the state.

### **Literature Review**

#### **Concept of entrepreneurship**

Entrepreneurship is a process concerned with the recognition, discovery and creation of opportunity where opportunity creation of new value to the society is in part or whole. The discovery and creation of opportunities and their ensuing pursuit by individuals have time after time been a focus of entrepreneurship (Grecu & Denes, 2017). Following the same line of thinking, Ireland and Webb (2007) indicate that entrepreneurship involves the aspect of opportunity seeking and seeks to comprehend how specific persons discover how to create new opportunities and then use them to exploit and develop a wide range of effects (Munyoro, Makota & Tanhara, 2016). In other words, entrepreneurship is a process by which employees in an organization pursue opportunities regardless of the scarcity of resources they currently control (Ireland and Webb, 2007; Dumbu, 2014). Additionally, Stevenson and Sahlman (1991) view entrepreneurship as a process of identifying opportunities, bringing required resources together, employing practical action plans and eventually reaping the reward in a fitting and flexible manner. For example, entrepreneurship creates new organizations which contribute to the social and economic development of countries. Therefore, organizational creation, renewal or innovations which occur within or outside an existing organization are all forms of entrepreneurship (Munyoro & Gumisiro, 2017; Mwenje, 2018). Whilst, Grecu and Denes (2017), Kaburi et al. (2012) and Munyoro et al. (2016) view an entrepreneur as an individual who creates a new business in the face of risk and uncertainty for the sole rationale of achieving both profit and growth by discovering opportunities and assembling the necessary resources to make the most of these opportunities. Likewise, an entrepreneurial organization pursues opportunity, without little regard to the resources currently available (Dumbu, 2014; Munyoro et al., 2016).

Munyoro et al. (2016) further view the relationship between entrepreneurship and culture and concludes that it indicates the needs and habits of a particular nation or region which then shape the behaviour of entrepreneurs and additionally, entrepreneurship fosters the knack of entrepreneurs to willingly become predisposed by turning new ideas or inventions into successful innovations, a phenomenon occasionally referred to as “creative destruction”. However, Wang (2012) and Al Qudah (2018) suggest that entrepreneurship is an elusive concept because entrepreneurship is defined and measured differently across countries.

### **Entrepreneurial Culture**

Entrepreneurial culture is the combination of personal values, managerial skills, experiences and behaviours that set apart the entrepreneur in terms of spirit of initiatives, risk taking, innovative capacity and management of firms' relations with the economic environment (Wong, 2014; Grecu & Denes, 2017). Nevertheless, other scholars argue that entrepreneurial culture is a national scheme of mutual values in a particular society that encompasses and supports entrepreneurship (Thurik & Dejardin, 2014). In a way, this point out that an entrepreneurial culture is distinguished by manifold expectations plus it facilitates the strategic management of firm's resources effectively. Additionally, Heiko (2013) and Wong (2014) further explain that an effective entrepreneurial culture is dedicated to the continuous opportunity-seeking and advantage seeking Munyoro and Phiribehaviours which are defined by the creation of new ideas, risk taking and giving up is not an option. Likewise, an entrepreneurial culture promotes learning and champions product, service, process and administrative innovations whilst at the same time opening windows of opportunities and this is thought to be absent in the Nigerian universities (Dumbu, 2014). Therefore, a sustainable competitive advantage can be achieved by fostering an entrepreneurial culture on university students who wish to start their own ventures and constantly are on the lookout for entrepreneurial opportunities to exploit. In fact, scholars like Minguzzi and Passaro (2000) delineate entrepreneurial culture as the blend of personal values, managerial skills, experiences and behaviours that typify the entrepreneur in terms of spirit of initiative, risk taking and innovative competence to produce new inventions. Consequently, an entrepreneurial culture enables a setting where individuals are enthusiastic to create innovations and are prepared to take calculated risks (Ngorora & Mago, 2013; Suzanne, 2013). Henceforth, an entrepreneurial culture is a system of shared values that closely hold and prop up entrepreneurship (Munyoro et al., 2016; Munyoro & Gumisiro, 2017).

Similarly, entrepreneurship is a condition where children are encouraged and taught by their parents to become future entrepreneurs by taking the necessary risks to start their own enterprise initiatives that result in self-employment and self-sustenance (Chakraborty et al, 2016). Furthermore, entrepreneurial culture is accountable for altering people's frame of mind into taking charge of oneself through creating self-employment rather than awaiting to qualify to get a job in a corporation or government institution as is always the case with graduates world over (OECD, 2013; Muntanga, 2014; Akuegwu and Nwi-Ue, 2016). That said, a society that does not encourage an entrepreneurial culture will definitely not achieve economic growth but will also encounter high rate of unemployment as part of its problems as is the case with Zimbabwe Witter, 2012). Furthermore, in societies where entrepreneurial culture is present, individuals will discover aspirations in challenges enabling them to exploit efficiently existing opportunities (Suzanne, 2013). In fact, opportunity seeking and creation of new value are significant commonalities to the theory of entrepreneurial culture (Nwokolo, 2015). In light of the above, these definitions seem to share the fact that an entrepreneurial culture

entails collective values, skills, experiences and behaviours that set apart an entrepreneur from an ordinary individual (Bux, 2016).

### **Theoretical Review**

#### **McClelland: The need for achievement theory**

According to Nwokolo (2015) and Kaburi et al. (2012), McClelland is one of the scholars who suggested that there is relationship between entrepreneurship and culture hence the term entrepreneurial culture and evidently, it is noted that the theory is correlated to entrepreneurial initiatives and the economic development of nations. Furthermore, the theory elucidates that there is a fairly great number of entrepreneurial activities in societies where entrepreneurial culture is supported and this simultaneously translate to high levels of need for achievement (Narry, 2018). Consequently, the crux of the theory is that once students are adequately motivated to have high needs for achievement through entrepreneurial culture and entrepreneurship education there is a vast possibility that they will set up their own businesses easily after completion of their studies (Nwokolo, 2015). Similarly, Woodside et al. (2015) concurs that the theory of need for achievement propels the human mind to do better, quickly and effectively in any activity which it sets its mind on and this in most cases is a direct result of education and experience for others (Thurik & Dejardin, 2012; Qiao, 2017). Meanwhile, it should be noted that the need to succeed differs in individuals as indicated by Oosterlinck (2016). In light of the above mentioned this longing for achievement becomes a constant push which motivates an individual to become an entrepreneur. Following this same line of reasoning, Woodside et al. (2016) adds this theory, explaining and foretells an individuals' performance behaviour compelled by a need for achievement, power and affiliation. Having said that, the recognizable psychological characteristics of people with high need of achievement are moderate risk partiality, innovativeness, and internal locus of control in their behaviour and a high sense of responsibility in decision making to ascertain how they achieve their goals as argued by Woodside et al. (2015).

### **Empirical Review**

Njugi and Agusioma (2014) studied the effect of organization culture on organizational performance in non-financial institutions with a specific focus on World Vision Kenya. Using a linear regression analysis to find out how organizational culture correlated with organizational performance, the study established that organizational culture significantly influenced performance by enhancing organizational philosophy, work atmosphere, performance targets and organizations stability. The research conducted by Arisi-Nwugballa, Elom and Onyeizugbe (2016) was carried out in Nigeria. They investigated the impact of the dimensions of Entrepreneurial Orientation on the performance of Micro, Small and Medium Enterprises (MSMEs) in Ebonyi State. The study employed survey research design and Pearson Product Moment Correlation was utilized for data analysis. The results revealed that the three dimensions of Entrepreneurial Orientation were relevant to one measure of the performance of MSMEs. Furthermore, the study confirmed that competitive aggressiveness had a significant relationship with both customer and product performance. In addition, Innovativeness and pro-activeness had a significant correlation with customer performance. Risk-taking and autonomy had no significant correlation with any of the performance measures, implying that they are not relevant to the performance of MSMEs. Kumarpeli & Semasinghe (2015) examined the association between Entrepreneurial Orientation and growth of SMEs in Sri Lanka through descriptive research design and Analysis of Variance (ANOVA) methodologies. It also investigated the relationship between the three

dimensions of Entrepreneurial Orientation– innovativeness, risk-taking, and pro-activeness on the growth of SMEs. Data were sought through questionnaires and analyzed through the help of descriptive statistical techniques to test the formulated hypotheses. The results showed that Entrepreneurial Orientation has an impact on the growth of SMEs. In addition, the results revealed that innovativeness and risk-taking have a positive impact on the growth of SMEs. Nevertheless, the findings showed that pro-activeness has no significant impact on the growth of SMEs. Baker, Mahmood and Ismail (2015) employed survey research design and Partial Least Square (PLS) methodologies on a sample of 500 SMEs owners/managers that were randomly selected from registered SMEs to examine the relationship between Entrepreneurial Orientation, strategic improvisation and performance of SMEs in Malaysia. Data were collected through mail questionnaires and the results showed that there is a significant relationship between Entrepreneurial Orientation and the performance of SMEs.

Employing principally existing literature relevant to the subject matter of the study, Okeyo, Gathungu and K'Obonyo (2016) investigated the relationship between Entrepreneurial Orientation, business development services, business environment and firm's performance. They concluded after reviewing previous researches in this area that “past studies conceptualized entrepreneurial orientation as a three-factor single-dimensional model and a five-factor multidimensional model. Studies using the three factor model have reported different results to those adopting the five-factor approach. This has led to inconsistencies in the empirical results of entrepreneurial orientation on firm's performance. The results also showed that business development services play a mediating role in the Entrepreneurial Orientation and performance relationship and that external environment moderates this relationship. Nevertheless, the results showed no role of internal environment in the Entrepreneurial Orientation -firm's performance relationship. Amin (2017) investigated the impact of Entrepreneurial Orientation and learning orientation on SMEs performance in Malaysia employing Partial Least Squares Structural Equation Modeling (PLS-SEM) and descriptive research design on a sample of 250 SMEs and 200 SMEs selected randomly from the electronic and electrical sector and beverage industries respectively. The results revealed that entrepreneurial orientation dimensions (innovativeness, pro-activeness, and risk-taking) and learning orientation have a significant relationship with the performance of SMEs.

### **Methodology**

A survey research design was used for this research work. The research design was designed in a way that enabled the researcher to effectively collect data that met the objectives of the study. The population of this study consists of all the residents of Ondo State. According to Ondo State profile, the population of Ondo State is 3,460,877 and this was considered for the study. The random sampling technique was adopted for the study to select 10 respondents from each of the 18 local government areas in Ondo state. Therefore, the sample size for this study was 180 respondents in Ondo State. For the purpose of this research, relevant data were gathered using primary source of data. The test of hypotheses was analyzed using Chi - square to test the Hypotheses at 5% level of significance.

### **Data Presentation and Analysis**

This section deals with the presentation and analysis of data collected through questionnaire from the 180 respondents selected as samples in the study area. A total of 180 copies of questionnaire were administered to the respondents and 168 the copies of questionnaire were retrieved completely.

**Table 1: Gender of the Respondents**

Gender	Frequency	Percentage
Male	96	57.1
Female	72	42.9
Total	168	100%

**Source:** Field Survey, 2022

From table 1 above, 57.1% of the respondents were male while 42.9% were female. This indicate that most of the respondents were male

**Table 2: Age of the Respondents**

Age	Frequency	Percentage
20 -29	18	10.7
30 – 39	72	42.9
40 – 49	45	26.9
50 & above	33	19.5
Total	168	100%

**Source:** Field Survey, 2022

From table 2 above, 10.7% of the respondents were between 20-29 years of age, 42.9% were between 30-39 years of age, 26.9% were between 40-49 years of age and 19.5% were 50 years and above. This means that majority of the respondents were between 30 – 39 years of age

**Table 3: Years of Experience of the Respondents**

Years of Experience	Frequency	Percentage
0 -5 years	36	21.4
6 – 10	42	25.0
11 – 15	51	30.4
16 – 20	21	12.5
21 years & above	18	10.7
Total	168	100%

**Source:** Field Survey, 2022

From the above table, 21.4% of the respondents have between 0 -5 years of experience, 25.0% of the respondents have between 6-10 years of experience, 30.4% of the respondents have between 11-15 years of experience, 12.5% have between 16-20 years of experience and 10.7% of the respondents have 21 years of experience and above.



**Table 4: Educational Qualification of the Respondents**

Educational Qualification	Frequency	Percentage
SSCE	18	10.7
OND/NCE	42	25.0
HND/BSC	87	51.8
PGD/MSC	21	12.5
Total	168	100%

**Source:** Field Survey, 2022

From the above table, 10.7% of the respondents were SSCE holders, 25.0% of the respondents were OND/NCE holders, 51.9% of the respondents were HND/BSC and 12.5% of the respondents were PGD/MSC holders. This signifies that majority of workers in the Oluji Cocoa Industry were HND/BSC holders.

	Frequency	Percent	Valid Percent	Cumulative Percent
Strongly Disagree	18	10.7	10.7	10.7
Disagree	3	1.8	1.8	12.5
Undecided	15	8.9	8.9	21.4
Agree	96	57.1	57.1	78.6
Strongly Agree	36	21.4	21.4	100.0
Total	168	100.0	100.0	

**Source:** Field Survey, 2022

The table revealed that 21.4% of the respondents strongly agree, 57.1% of the respondents agree that entrepreneurial culture helps in business set up among the youth while 8.9%, 1.8% and 10.7% of the respondents were undecided, disagree and strongly disagreed respectively to this notion. This means that majority of the respondents agreed that entrepreneurial culture helps in business set up among the youth.

**Table 6: Entrepreneurial Culture Provide Job Opportunity for Youth**

	Frequency	Percent	Valid Percent	Cumulative Percent
Strongly Disagree	3	1.8	1.8	1.8
Disagree	6	3.6	3.6	5.4
Undecided	18	10.7	10.7	16.1
Agree	84	50.0	50.0	66.1
Strongly Agree	57	33.9	33.9	100.0
Total	168	100.0	100.0	

**Source:** Field Survey, 2022

The table revealed that 33.9% of the respondents strongly agree, 50.0% of the respondent agree that entrepreneurial culture provide job opportunity for youth while 10.7%, 3.6% and 1.8% of the respondents were undecided, disagree and strongly disagreed respectively to this notion. This means that majority of the respondents know that the entrepreneurial culture provides job opportunity for youth.



**Table 7: Entrepreneurial Culture Bring About Innovation to Business Activities for Youth**

	Frequency	Percent	Valid Percent	Cumulative Percent
Strongly Disagree	27	16.1	16.1	16.1
Disagree	21	12.5	12.5	28.6
Undecided	12	7.1	7.1	35.7
Agree	75	44.6	44.6	80.4
Strongly Agree	33	19.6	19.6	100.0
Total	168	100.0	100.0	

Source: Field Survey, 2022

The table revealed that 19.6% of the respondents strongly agree, 44.6% of the respondent agree that entrepreneurial culture bring about innovation to the organization while 10.7%, 3.6% and 1.8% of the respondents were undecided, disagree and strongly disagreed respectively to this notion. This means that majority of the respondents know that entrepreneurial culture brings about innovation to the organization.

**Table 8: Entrepreneurial Culture Increase Risk Taking Ability of the Organization**

	Frequency	Percent	Valid Percent	Cumulative Percent
Strongly Disagree	4	7.1	7.1	7.1
Disagree	3	5.4	5.4	12.5
Undecided	5	8.9	8.9	21.4
Agree	21	37.5	37.5	58.9
Strongly Agree	23	41.1	41.1	100.0
Total	168	100.0	100.0	

Source: Field Survey, 2022

The table revealed that 41.1% of the respondents strongly agree, 37.5% of the respondents agree that entrepreneurial culture increase risk taking ability of the organization while 8.9%, 5.4% and 7.1% of the respondents were undecided, disagree and strongly disagreed respectively to this notion. This means that majority of the respondents agreed that entrepreneurial culture increase risk taking ability of the organization.

**Table 9: Exposure to Occupational Experience Assist Youth to be Business Oriented**

	Frequency	Percent	Valid Percent	Cumulative Percent
Strongly Disagree	1	1.8	1.8	1.8
Disagree	1	1.8	1.8	3.6
Undecided	3	5.4	5.4	8.9
Agree	29	51.8	51.8	60.7
Strongly Agree	22	39.3	39.3	100.0
Total	168	100.0	100.0	

Source: Field Survey, 2022

The table revealed that 39.3% of the respondents strongly agree, 51.8% of the respondents agree that exposure to occupational experience assist youth to be business oriented while 5.4%, 1.8% and 1.8% of the respondents were undecided, disagree and strongly disagreed respectively to this notion. This means that exposure to occupational experience assist youth to be business oriented.

**Table 10:** Exposure to Occupational Experience Increase

	Frequency	Percent	Valid Percent	Cumulative Percent
Strongly Disagree	6	10.7	10.7	10.7
Disagree	5	8.9	8.9	19.6
Undecided	1	1.8	1.8	21.4
Agree	12	21.4	21.4	78.6
Strongly Agree	32	57.1	57.1	100.0
Total	168	100.0	100.0	

**Source:** Field Survey, 2022

The table revealed that 57.1% of the respondents strongly agree, 21.4% of the respondents agree that exposure to occupational experience increase while 1.8%, 8.9% and 10.7% of the respondents were undecided, disagree and strongly disagreed respectively to this notion. This means that majority of the respondents agreed that exposure to occupational experience increase

**Table 11:** Exposure to Technical Knowledge lead to job creation among youth in Ondo State

	Frequency	Percent	Valid Percent	Cumulative Percent
Strongly Disagree	-	-	-	
Disagree	5	8.9	8.9	8.9
Undecided	7	12.5	12.5	21.4
Agree	14	25.0	25.0	46.4
Strongly Agree	30	53.6	53.6	100.0
Total	168	100.0	100.0	

**Source:** Field Survey, 2022

The table revealed that 53.6% of the respondents strongly agree, 25.0% of the respondents agree that exposure to technical knowledge lead to job creation among youth in Ondo State while 12.5% and 8.9% of the respondents were undecided and disagree respectively to this notion. This means that majority of the respondents agreed that exposure to technical knowledge lead to job creation among youth in Ondo State.

**Table 12: Technical Knowledge Increase Entrepreneurship Culture Among Youth in Ondo State**

	Frequency	Percent	Valid Percent	Cumulative Percent
Valid Strongly Disagree	5	8.9	8.9	8.9
Disagree	3	5.4	5.4	12.5
Undecided	4	7.1	7.1	21.4
Agree	23	41.1	41.1	58.9
Strongly Agree	21	37.5	37.5	100.0
Total	168	100.0	100.0	

Source: Field Survey, 2022

The table revealed that 37.5% of the respondents strongly agree, 41.1% of the respondents agree that technical knowledge increase entrepreneurship culture among youth in Ondo State while 21.4%, 5.4% and 8.9% of the respondents were undecided, disagree and strongly disagreed respectively to this notion. This means that majority of the respondents agreed that technical knowledge increase entrepreneurship culture among youth in Ondo State.

**Table 13: Exposure to Technical Knowledge Help Youth to be Creative and Innovation Ondo State**

	Frequency	Percent	Valid Percent	Cumulative Percent
Valid Strongly Disagree	4	7.1	7.1	7.1
Disagree	2	3.6	3.6	10.7
Undecided	2	3.6	3.6	14.3
Agree	7	12.5	12.5	26.8
Strongly Agree	41	73.2	73.2	100.0
Total	168	100.0	100.0	

Source: Field Survey, 2022

The table revealed that 73.2% of the respondents strongly agree, 12.5% of the respondent agree that exposure to technical knowledge help youth to be creative and innovation Ondo State while 3.6%, 3,6% and 7.1% of the respondents were undecided, disagree and strongly disagreed respectively to this notion. This means that majority of the respondents accepted that exposure to technical knowledge help youth to be creative and innovation Ondo State.

**Table 14: Exposure to Technical Knowledge Enhance Job Experience Among Youth in Ondo State**

	Frequency	Percent	Valid Percent	Cumulative Percent
Valid Strongly Disagree	3	5.4	5.4	5.4
Disagree	5	8.9	8.9	14.3
Undecided	1	1.8	1.8	16.1
Agree	27	48.2	48.2	64.3
Strongly Agree	20	35.7	35.7	100.0
Total	168	100.0	100.0	

Source: Field Survey, 2022

The table revealed that 35.7% of the respondents strongly agree, 48.2% of the respondent agree that exposure to technical knowledge enhance job experience among youth in Ondo State while 1.8%, 8.9% and 5.4% of the respondents were undecided, disagree and strongly disagreed respectively to this notion. This means that majority of the respondents accepted that exposure to technical knowledge enhance job experience among youth in Ondo State.

**Test of Hypotheses**

**H<sub>01</sub>:** There is no significant relationship between exposure to technical knowledge and job creation among youth in Ondo State

**Test Statistics**

	There is no significant relationship between exposure to technical knowledge and job creation among youth in Ondo State
Chi-Square	35.071
Df	4
Asymp. Sig.	.000

Source: Field Survey, 2022

The table revealed that 35.7% of the respondents strongly agree, 48.2% of the respondent agree that exposure to technical knowledge enhance job experience among youth in Ondo State while 1.8%, 8.9% and 5.4% of the respondents were undecided, disagree and strongly disagreed respectively to this notion. This means that majority of the respondents accepted that exposure to technical knowledge enhance job experience among youth in Ondo State.

**Test of Hypotheses**

**H<sub>01</sub>:** There is no significant relationship between exposure to technical knowledge and job creation among youth in Ondo State

a. 0 cells (0.0%) have expected frequencies less than 5. The minimum expected cell frequency is 11.2.

Calculated chi-square ( $\chi_{cal}$ ) = 35.071  
 Tabulated ( $\chi_{tab}$ ) = 9.49  
 Degree of Freedom (df) = 4  
 Level of Significance = 0.05

Decision Rule: Calculated chi-square ( $\chi_{cal}$ ) which is 35.071 is greater than the tabulated chi-square ( $\chi_{tab}$ ) which is 9.49 at 5% level of significance. Therefore, the null hypothesis is rejected and the alternative hypothesis is accepted, this means that there is no significant relationship between exposure to technical knowledge and job creation among youth in Ondo State

**Test of Hypothesis Two**

**H<sub>02</sub>:** There is no significant relationship between exposure to occupational experience and job creation among youth in Ondo State

**Test Statistics**

	There is no significant relationship between exposure to occupational experience and job creation among youth in Ondo State
Chi -Square	51.416 <sup>a</sup>
Df	4
Asymp. Sig.	.000

**Source** : Field Survey, 2022

a. 0 cells (0.0%) have expected frequencies less than 5. The minimum expected cell frequency is 11.2.

Calculated chi-square (  $\chi_{cal}$  ) = 51.416  
 Tabulated (  $\chi_{tab}$  ) = 9.49  
 Degree of Freedom (df) = 4  
 Level of Significance = 0.05

Decision Rule: Calculated chi-square (  $\chi_{cal}$  ) which is 51.416<sup>a</sup> is greater than the tabulated chi-square (  $\chi_{tab}$  ) which is 9.49 at 5% level of significance. Therefore, the null hypothesis is rejected and the alternative hypothesis is accepted, this means that there is no significant relationship between exposure to occupational experience and job creation among youth in Ondo State

**Conclusion**

From the result of the study, it can be concluded that entrepreneurial culture contributed to setting up of small business among the youth in Ondo State. The entrepreneurial culture led to exposures to technical knowledge, occupational experience and risk taking among youths in Ondo State. Also, exposures to technical knowledge, occupational experience and risk taking have positive and significant relationship on job creation and reduce level of unemployment among youth in Ondo State. The study recommended that there is need to formulate policy to enforced implementation of entrepreneurial culture so as to expand business operations in Nigeria and that Youths should be expose to technical and occupational knowledge in order to expand business creation

**References**

Aardt, I., Van Aardt, C., Bezuidenhout, S. & Mumba, M. (2008). *Entrepreneurship and new venture management*. 3rd Edition. Oxford University Press: Southern Africa Retrieved from [www.oxford.co.za](http://www.oxford.co.za)

Abimbola, O. H., Olowu, A. U. & Paul, D. (2016). *Youth unemployment and entrepreneurship prospects in Nigeria: A developmental perspective*. Ife Centre for Psychological Studies/Services, Ile Ife, Nigeria. Retrieved from [www.ajol.info](http://www.ajol.info)

- Aina, J. K., Abdulrahman, A. O. & Abdulwasiiu, A. A. (2019). Entrepreneurial skills in science through authentic learning strategy: A panacea for youth unemployment in Nigeria. *South Asian Research Journal of Humanities and Social Sciences*, 1, 10-14. Retrieved from [www.sarpublication.com/sarjhss](http://www.sarpublication.com/sarjhss)
- Akuegwu, B. A., & Nwi-Ue, F. D. (2016). Developing entrepreneurship culture among university students in South South, Nigeria. *Mediterranean Journal of Social Sciences*, 7(2 S1), 315-324.
- Alemu, S. K. (2018). The meaning, idea and history of university/ higher education in Africa: A brief literature review. *Forum for International Research in Education*, 4(3), 210-227.
- Andretsch, D. B., Grilo, I. & Thunik, A. (2007). *Handbook of research in entrepreneurship policy*. Cheltenham: Edward Elger Publishers.
- Chakraborty, S., Thompson, J. C., & Yehoue, E. B. (2016). The culture of entrepreneurship. *Journal of Economic Theory*, 163, 288-317.
- Davidsson, P., Delmar, F. & Wiklund, J. (2006). Entrepreneurship as growth: Growth as entrepreneurship. In Davidsson, P., Delmar, F. & Wiklund, J. (Eds.) *Entrepreneurship and the growth of firms*. Edward Elgar Publishing, United Kingdom, England, Cheltenham, 21-38.
- Dumbu, E. (2014). Promoting entrepreneurship through open and distance education in Zimbabwe. A case study of the Zimbabwe Open University students at Masvingo regional campus. *International Journal of Business, Economics and Management*, 1(6), 101-114.
- Ekanem, E. E. (2015). Entrepreneurs and natural development. *Nigeria Academy of Management Journal*, 109-124. Retrieved from [www.tamn-ng.org](http://www.tamn-ng.org)
- Foss, N.J., & Lyngsie, J. (2011). The emerging strategic entrepreneurship field: Origins, key tenets, and research gaps. *Strategic Management and Globalization working paper*, No. 7
- Fukuyama, F. (2001). Culture and economic development. Cultural concerns. *International Encyclopedia of the Social and Behavioural Science*, Elsevier Amsterdam, Pp. 3130-3134.
- Greco, V., & Denes, C. (2017). Benefits of entrepreneurship education and training for engineering students. In *MATEC Web of Conferences* (Vol. 121, p. 12007). EDP Sciences.
- Ireland, R. D., Ketchen Jr, D. J. & Snow, C. C. (2007). Strategic entrepreneurship, collaborative innovation, and wealth creation. *Strategic Entrepreneurship Journal*, 1(3-4), 371-385.
- Khan, M. M., Zhang, J., Hashmi, M. S., & Bashir, M. (2010). Cultural values and economic growth in Asia. An empirical analysis. *International Journal of Business and Social Science*, 1(2), 15-27.



- Mba, O. A. & Godday, R. L. (2014). Entrepreneurship development and unemployment reduction in Nigeria: A survey of public opinion in selected Nigerian cities. *Business & Entrepreneurship Journal*, 3(2), 67-84. Retrieved from [www.ideas.repec.org](http://www.ideas.repec.org).
- McClelland, D. C. (1965). Toward a theory of motive acquisition. *American Psychologist*, 20, 321-333.
- Minola, T., Criaco, G. & Obschonka, M. (2016). Age, culture, and self-employment motivation. *Small Business Economics*, 46(2), 187-213. doi: 10.1007/s11187-015-9685-6.
- Moen, J., Rahman, I., Salleh, M. & Ibrahim, R. (2004). A study on entrepreneurial attitudes among youths in Malaysia, case study: Institute Kemahiran Belia Negara, Malaysia. *The Journal of American Academy of Business*, 197.
- Monsen, E., & Boss, W. R. (2009). The impact of strategic entrepreneurship inside the organization: Examining job stress and employee retention. *Entrepreneurship Theory & Practice*, 33(1), 71-104.
- Morris, M., & Schindehutte, M. (2005). Entrepreneurial values and the ethnic enterprise: An examination of six subcultures. *Journal of Small Business Management*, 43(4), 453-479.
- Munyoro, G., & Gumisiro, C. (2017). The significance of entrepreneurial culture in the security sector: A case study of Zimbabwe prisons and correctional service. *IMPACT: International Journal of Research in Business Management*, 5(5), 15-28.
- Munyoro, G., Makota, B., & Tanhara, J. R. (2016). The significance of entrepreneurial culture in vocational training centres. A case study of Mupfure vocational centre. *IMPACT: International Journal of Research in Business Management*, 4(10), 55-70.
- National Bureau of Statistics (2020). Labor force statistics: Unemployment and underemployment report (q2 2020) national bureau of statistics report date: August 2020 data source: National Bureau of Statistics (NBS) abridged labour force survey under covid-19. Retrieved from [www.nigerianstat.gov.ng](http://www.nigerianstat.gov.ng).
- Neumann, T. (2020). The impact of entrepreneurship on economic, social and environmental welfare and its determinants: A systematic review. *Management Review Quarterly*. doi: 10.1007/s11301-020-00193-7.
- Ngorora, G. P. K., & Mago, S. (2013). Challenges of rural entrepreneurship in South Africa: Insights from Nkonkobe Municipal Area in the Eastern Cape Province. *International Journal of Information Technology and Business Management*, 16(1), 1-11.
- Nhuta, S. & Kapofu, W. (2015). Evaluation of strategic entrepreneurship approaches for sustainable growth in the commercial banking sector in Zimbabwe. *International Journal of Contemporary Applied Sciences*, (2), 57-83.

- Nwachukwu, L. C. & Nwamuo, P. (2010). Entrepreneurship development for sustainable livelihood among youths in Imo State: Implications for Counselling. Conference Proceedings CASSON 2010,1, 18-26.
- Nwokolo, E. (2015). Entrepreneurship education as a strategy for the promotion of entrepreneurship culture and poverty reduction among university students. University of Fort Hare.
- OECD (2013). *Culture: The role of entrepreneurship education in entrepreneurship at a glance 2013*. London: OECD Publishing.
- Ogunbanjo, O. A., Afolabi, M. O., Aninkan, O. O., Ogunsola, M. O. & Orobiyi, J. O. (2017). Causes and effects of graduate unemployment on the Nigerian economy (The case study of Lagos State). *Asian Research Journal of Arts & Social Sciences*, 2, 2-10. doi: 10.9734/ARJASS/2017/30722
- Olusakin, A. M. (2010). Counselling for sustainable livelihoods with target clients: The Nigeria adolescents and Youths. A lead paper presentation at the 2010 Conference of the Counselling Association of Nigeria (CASSON) held at Enugu.
- Rauch, A., & Frese, M. (2007). Let's put the person back into entrepreneurship research: A meta-analysis on the relationship between business owners' personality traits, business creation, and success. *European Journal of Work & Organizational Psychology*, 16(4), 353-385.
- Rehman, A. U. & Elahi, Y. A. (2012). Entrepreneurship education in India-scope, challenges and role of B-schools in promoting entrepreneurship education. *International Journal of Engineering and Management Research*, 2(5), 5-14.
- Shariff, M. & Peou, C. (2008). The relationship of entrepreneurial values, firm financing and the management and growth performance of small-medium enterprises in Cambodia. *Problems and Perspectives in Management*, 6(4), 55- 64.
- UNESCO (2018). The Global Education meeting held in Brussels, Belgium from 3rd to 5th December 2018
- Urban, B. (2007). A framework for understanding the role of culture in entrepreneurship. *Acta Commercii*
- Usioboh, A. M. (2008). *Basic business management*. Lagos; Ladder Press.
- Usmam, I. S, Waziri, U. M, Abdullahi, A. & Babayo A. A. (2018). Students' participation in entrepreneurship skills acquisition programmes in Adamawa state polytechnic Yola, Nigeria. *Biodiversity International Journal*, 2(2), 181-185. doi: 10.15406/bij.2018.02.00061
- Van der Post, W. Z., de Coning, T. J. & Smit, E. V. (1998). The relationship between organisational culture and financial performance: some South African evidence. *South African Journal of Business Management*, 29(1), 30-4.

- Walstad, W. B. & Kourilsky, M. L. (1998). Entrepreneurial attitudes and knowledge of black youth. *Entrepreneurship: Theory & practice*, 23(2), 5-18.
- Wickham, P. A. (2006). *Strategic entrepreneurship* 4th ed, Harlow: Financial Times Prentice
- Wang, R. (2012). Chinese culture and its potential influence on entrepreneurship. *International Business Research*, 5(10), 76-90.
- White, S. & Kenyon, P. (2000). Enterprise-based youth employment policies, strategies, and programs', ILO, Geneva. Retrieved from [www.ilo.org](http://www.ilo.org).
- Zouhayer, M. (2013). Entrepreneurial culture, profile of the leader and entrepreneurial orientation: Empirical application in the case of the Tunisian Companies. *IJRDO- Journal of Business Management*, 4(3), 15.



## Utilization of Learning Activity Package on Academic Achievement and Retention Among N.C.E. Biology Students in Federal College of Education Zaria, Kaduna State

<sup>1</sup>Shittu Adeniyi Michael, <sup>2</sup>Omoniwa Oluwatope Olubunmi  
& <sup>3</sup>Michael Jonathan Dadiya  
*Department of Biology, School of Secondary Education-Science  
Federal College of Education, Zaria*

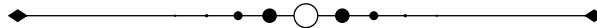

### *Abstract*

**T**his study analyzed the Utilization of Learning Activity Package (LAP) on Academic Achievement and Retention among N.C.E. Biology Students in Federal College of Education Zaria, Kaduna State". Two objectives and two research questions served as the foundation for the study. A quasi-experimental design was used. All N.C.E. Biology students at the Federal College of Education in Zaria, Kaduna State, made up the population. To sample 200 students, a simple random sampling (balloting) procedure was used. The test used for this study was the Biology Achievement Test (BAT), which consisted of 25 multiple-choice questions, each with four possible answers and one correct response. Students took an achievement test that was used to gather data, and that data was then analysed using the t-test, standard deviation, and mean statistical analysis. According to the study's results, there is a noticeable difference between students who were taught biology using the learning activity package and those who were not. The following conclusions and recommendations were made: Teachers at the Federal College of Education in Zaria, Kaduna State, should improve their methods for teaching and learning biology. Teaching with learning activity packages is also crucial for biology teachers at all levels of education in Nigeria.

**Keywords:** Learning activity package, Academic achievement, Biology students

---

## **Introduction**

Biology as a subject with a strong emphasis on hands-on experience, biology must be presented to students in such a way that they are encouraged to take an active role in their education (Akinwumi, & Olofin, 2022). Akwumi, & Olofin, 2022 explain that the study of biology encompasses not only the investigation of life but also its structures, functions, growth, origins, evolutions, distributions, interrelationships, diseases, and adaptations. According to Falebita and Olofin 2020, the lecture technique, which is utilised in the teaching of biology ideas, might offer the advantage of delivering vast amounts of material, which can be used to cover the extensive curriculum within a short length of time. However, the lecture technique, on the other hand, can hinder the learning processes of the students because learning is an active process and not just listening to the teacher (Falebita & Olofin, 2020). Learning requires students to actively participate in the process of learning. It would appear that the conventional method does not take into account the unique characteristics of each person. According to Njoku and Akamobi (2015), the Learning Activity Package (LAP) is a teaching procedure that is student-centred and activity-oriented. In this strategy, the instructor takes on the role of an implementer of learning, guiding the students through a series of exercises and challenges that may assist learners in achieving high levels of success. The learning activity package may incorporate a variety of different instructional methodologies, depending on the instructional goals of the unit or module that it is a part of. Because a large variety of different teaching methods may be combined into a website or webpage, it is possible for educators to successfully use these resources when building learning activity packages for students. The website or webpage in question may contain educational information (text, audio, and video), links to other websites, interactive activities, assignments, evaluation guides, and any other content that may be required, according to Njoku and Akamobi (2015).

Science and technology are essential tools for any nation's economic growth and improvement in worker productivity. Any nation that wants to ensure growth, maintain its position of honour among civilised nations, and maintain its independence, authority, and self-sufficiency must actively pursue knowledge. This is so because, among other things, science and technology offer the fundamental instruments for industrialization and economic development in the fields of communication, transportation, energy, knowledge, pollution control, and waste management. The teaching and learning of science have received a lot of attention in Nigeria since it is thought to be of such high importance. According to the National Policy on Education, the main objective of scientific education is to prepare students to successfully live in the modern world (FME, 2014). The teaching and learning of science have received a lot of attention because science is thought to be so important in Nigeria. The information, skills, and attitudes required in the scientific community can be instilled in the students to achieve this.

The only way for students to acquire the knowledge, abilities, and attitudes necessary to succeed in science is through the appropriate instruction of the many different scientific disciplines. The fields of biology, chemistry, and physics, as well as mathematics, health science, and agriculture, fall under this area. One of the scientific courses, biology can help students find answers to both internal and external problems if it is taught properly. Understanding biology enables one to maintain good health practises such as the use of clean water, excellent sanitation, balanced food, and the necessity of vaccination, among other things. It also helps one to question superstitions, know the function of the many parts of the body, and understand oneself (Maduabum, 2008). To be accepted into any Nigerian university

and pursue significant science-based programmes like medicine, pharmacy, biochemistry, microbiology, food technology, and others, a candidate must earn a credit pass in biology. This serves to further highlight the importance of biology as a secondary education topic.

### **Statement of Problem**

Research findings and WAEC Chief Examiners' Reports both show that pupils continue to do poorly in biology, which is cause for concern, especially for biology teachers who enrol more students. The teachers' ineffective teaching methods, particularly the lecture-based, teacher-centered approach, have been related to the issue in major part. Since it is believed that student engagement can lead to meaningful learning, it is regarded necessary to enhance the biology teaching and learning process by researching the usage of various innovative learner-centered teaching and learning strategies. Despite the fact that numerous studies have been conducted on a variety of novel approaches, including computer-assisted instruction and programmed instruction, findings have shown that they are student-centered and can also promote learning and accomplishment, but the issue of large classes and the lack of computer equipment in the majority of Nigerian courses has made their implementation practically impossible. There is still a need to investigate various kid-centered approaches that are affordable, accessible, and adaptable and incorporate both packaged learning and hands-on activities. With the use of such an approach, the instructor should be able to quickly identify the problems that a certain student is having while allowing the students to assess themselves and learn the results right away. This necessitates testing out a different personalised technique, such the Learning Activity Package (LAP). Hence, the study was set up to find an answer to the question: "What is the effect of LAP on students' academic achievement and retention among Nigeria Certificate of Education (NCE) students?" Biology in the Federal College of Education, Zaria, Kaduna State, Nigeria?

### **Significance of the Study**

The findings of this study are important from both a theoretical and practical standpoint. Theoretically, this study is supported by the idea that children actively engage with their surroundings as they develop their cognitive abilities. Accordingly, a child's capacity as he engages with his physical and social environment is the cornerstone of learning. According to the Piagetian theory of intellectual development, a child's environment actively influences how they develop cognitively. This is closely related to the student-centered Learning Activity Package (LAP). In other words, the LAP as a technique of instruction is consistent with the theory that emphasises the learner's active connection with his environment while the instructor directs or supports the interaction; as a result, the findings of this study will contribute to the validation of Piaget's theory.

### **Objective of the Study**

The objective of this study was to;

1. Assess the effect of LAP on N.C.E. biology students' academic achievement at the Federal College of Education in Zaria, Kaduna State.
2. Find out how the LAP affects students' retention among N.C.E. biology classes at the Federal College of Education in Zaria, Kaduna State.



### **Research Questions**

The following research questions were formulated:

1. What effect does the LAP have on students' N.C.E. biology academic achievement at the Federal College of Education in Zaria, Kaduna State?
2. What effect does the LAP have on N.C.E. Biology students' retention at the Federal College of Education in Zaria, Kaduna State?

### **Research Hypotheses**

The following hypotheses were created and tested at the 0.05 level of significance to guide the study:

- i. There are no appreciable differences in the mean academic achievement scores of students taught biology using the LAP and those taught using the Lecture Method.
- ii. There is no significant difference between students taught biology using the LAP and those taught using the Lecture Method in terms of their level of retention.

### **Methodology**

The study's design was a non-equivalent group design with a quasi-experimental pre-test and post-test. The approach is frequently employed in tests conducted in classrooms when the experimental and control groups are put together as intact classes with no chance for randomization. As a result, intact classes were utilised, and research subjects weren't chosen at random. All N.C.E. II Biology students at the Federal College of Education in Zaria, Kaduna State, made up the population. Using the sample size determination table from Krejcie and Morgan (1970), 200 biology students made up the study's sample. The researchers' Biology Achievement Test (BAT) is the tool used to gather data. The BAT is a twenty-item test with four response options (A–D) for multiple-choice questions. The researchers administered the pre-test and the test to the two schools that made up the sample: control school A and experimental school B. Here, the control school will receive the learning activity bundle, while the experimental school will receive lectures as the style of instruction. A post-test was again given one week after the pre-test had been given. A post-test (also known as a retention exam) was then given to see if the students had retained the material after about two weeks.

The Circulatory System Performance Test (CSPT) was the instrument used to collect data for this investigation. The test will be designed to evaluate the student's academic performance and comprehension of the subject being covered. The mean, standard deviation, and t-test statistical analyses will be used to examine the information acquired from the test that was given. Based on the performance test findings, an analysis will be done.

### **Results**

Descriptive statistics, such as mean and standard deviation, were utilised to analyse the acquired data in order to respond to study questions. The t-test technique was used to evaluate the research hypotheses for the study.

### **Answering Research Questions**

**Research Questions 1:** What effect does the LAP have on students' N.C.E. biology academic achievement at the Federal College of Education in Zaria, Kaduna State?

Table 1 provides the response to research question 1.

**Table 1: Students mean score level of retention of students taught using LAP and those taught using lecture method**

Method of teaching	No. of students	Mean score	Mean difference
LAP (Experimental group)	110	26.7	08.3
Lecture Method (control)	90	18.4	

In Table 1 above, the mean score of the students in the experimental group and the control group were displayed. Students in the experimental group received an average grade of 26.7, while those in the control group received an average grade of 18.4. The Experimental group was given a boost by the mean difference between the groups, which was calculated to be 8.3 marks. The mean disparity is substantial. Thus, we can draw the conclusion that LAP-taught biology students retain information better than lecture-taught biology students.

**Research Questions2:** What effect does the LAP have on N.C.E. Biology students' retention at the Federal College of Education in Zaria, Kaduna State?

The answer to research question 2 is presented in table 2

**Table 2: Interaction between teaching strategy and ability levels on students' achievement and retention in biology using LAP**

Method of teaching	No. of students	Mean score	Mean difference
LAP (Experimental Group)	110	24.6	07.3
Lecture (Control)	90	17.3	

In comparison to students who were taught biology using the lecture technique, those who were taught via LAP showed higher achievement and retention rates. This was seen in Table 2 above. The study showed that the control group's mean score was 17.3 while the experimental group's mean score was 24.6. The Experimental group was given a 7.3-mark advantage in the mean difference between the groups. The mean disparity is substantial. As a result, we can draw the conclusion that students who are taught biology via LAP do better than those who are taught using lectures.

### Hypothesis Testing

**H<sub>0</sub>:** The mean academic achievement scores of students taught biology using the LAP and those taught using the Lecture Method do not significantly differ from one another.

The above null hypothesis was t-tested and the result is presented in table 3.

**Table 3: t-test analysis of mean level of retention score of experimental and control groups**

Variables	N	Mean	SD	SE	DF	T-Value	P-Value	Conclusion
Experimental	110	24.6	3.633	0.672	40	6.314	0.003	Significant
Control	90	18.4	4.037	0.740				

The analysis of the t-test results for the level of retention score for the experimental and control groups is shown in Table 3 above; the resultant P-value was 0.003, which was less significant than 0.05. This suggests that using LAP to teach biology helps students in the experimental group retain information better than those in the control group. As a result, we reject both the null hypothesis and the alternative hypothesis, which contend that there are notable differences between students who were taught biology using LAP and those who were not.

**H<sub>0</sub>:** There is no significant difference between students taught biology using the LAP and those taught using the Lecture Method in terms of their level of retention.

The above null hypothesis was t-tested and the result is presented in table.

**Table 4: t-test analysis of mean academic achievement score experimental and control groups**

Variables	N	Mean	SD	SE	DF	T-Value	P-Value	Conclusion
Experimental	110	26.7	2.313	0.612	32	3.622	0.002	Significant
Control	90	17.3	3.377	1.524				

The analysis of the experimental and control groups' mean academic success scores is shown in Table 4.4. The outcome shows that the obtained P-value is 0.002, which is less significant than 0.05. The null hypothesis is thus disproved, and it is determined that there is a difference between the academic accomplishment of pupils who are taught biology with LAP and those who are not.

### Discussion of Findings

According to Table 3, pupils who are taught biology using LAP have better retention of information than those who are taught using lecture methods. This is consistent with the research conducted by Ugbe and Dike (2012) on the comparative impact of deploying student learning packages on student retention. It is also consistent with Mbajiogu's (2013) study, which examined students' acquisition and retention of science process abilities and uncovered the effects of the direct discovery technique and the demonstration method that motivation and allowing students to come to their own conclusions help with retention. Additionally, it is consistent with the findings of Ndukwe's (2000) study on SSI students' immediate accomplishment and retention in biology expository versus project-centred instruction.

The study's conclusions showed that there was no discernible difference between the pre-test performance of biology students who had used the Learning Activity Package (LAP) and those who had used the standard approach. At the start of this investigation, the students in the experimental and control groups were similar. Neboh (2012) revealed a substantial

difference between students who learned biology through lectures and LAP in terms of their academic accomplishment; LAP students performed better than lecture-taught students. He came to the conclusion that using cutting-edge techniques like the Learning Activity Package in the teaching and learning of science topics will significantly improve students' academic achievement. Abu (2018) discovered that LAP improved students' biology achievement regardless of their prior academic status. Furthermore, the research by Njoku and Akamobi (2015) and Ifeyinwa (2019) found a substantial difference in the retention test results of biology students who had used the Learning Activity Package (LAP) and those who had used the traditional approach. They come to the conclusion that LAP was successful in maintaining students' biology knowledge.

Table 4's data reveal that both students who were taught biology using the LAP and those who were taught using the lecture method achieved similar levels of achievement. This is consistent with Abu's (2018) study, which examined the efficiency of individualised and lecture instructional techniques for teaching biology at the senior secondary level of education in two schools in the Nigerian state of Kaduna's Zaria township. Mukalia (2000) studied the relationship between students' cognitive preference styles and computer- and text-assisted programmed instruction as predictors of secondary school proficiency in heat-related subjects in physics.

### **Conclusion**

In the light of the finding from this study, it was determined that, teaching and learning made real and practical in the experimental group which allow students to gain self-confidence, self-esteem, memory retention and higher performance after been taught through LAP. When taught using LAP, students understand the material and acquire it more quickly and effectively, and the level of performance is promoted among Biology N.C.E III Students in Federal College of Education Zaria, which is located in Kaduna State.

### **Recommendations**

The following suggestions were offered in light of the research's findings:

1. All Federal and State Colleges of Education in Nigeria should use LAP to teach biology.
2. LAP-based instruction is crucial in all Federal and State Colleges of Education in Nigeria because it increases student retention.
3. Instructors should be encouraged by management and school authorities to use LAP in all Federal and State Colleges of Education in Nigeria.

### **References**

- Abu. A. O. (2001). Resource utilization in classroom: The effect of learning activity package to teach biology at the senior secondary level of education. *JSTAN*, 40(2), 103 – 106.
- Awotua-Efebo, E. B. (2001). *Effective teaching: Principles and practice*. Paragraphics, Port Harcourt.
- Diamond, P. J. & Onwuegbuzie, A. J. (2001). Factors associated with reading, achievement and attitudes among elementary school-aged students. *Research in the Schools*, 8(1). 1 – 11.

- Eze, A. N. (1992). Sex and environment as factors in physics achievement. *International Journal of Education Research*, 17–23.
- Enohuean, V. O. (2018). Effects of instructional materials on achievement and retention of biology concepts among secondary school students in Delta State, Nigeria. Unpublished M.Ed. Dissertation. Department of Science Education Ahmadu Bello University, Zaria, Kaduna State.
- Falebita, O. S. & Olofin, S. O. (2020). Impact of teachers' instructional practices on students' achievement and self-efficacy in mathematics. *Commonwealth Journal of Academic Research*, 1(3), 1–14. DOI: 10.5281/zenodo.3879417
- Federal Ministry of Education (F.M.E) (2004). *National curriculum for senior secondary schools*. Lagos: Federal Ministry of Education.
- Maduabum, M. A. (1998). The relative effectiveness of the expository and guided discovery methods in secondary school student's achievement in biology. *Enugu State University of Science and Technology Journal of Education*, 1(1), 122–136.
- Mbajogu, N. M. (2013). The effect of direct discovery method and demonstration in acquisition and retention of science process skills. A paper presented at the Conference of Science and Technical Education Department ESUT.
- Mukaila, A. O. S. (2000). Computer and text assisted programme instruction and students' cognitive preference style as determinants of secondary school achievement in heat related concepts in physics. Unpublished Ph.D. Thesis. University of Ibadan.
- National Research Council (2000). *How people learn*. Washington D. C.: The National Academics Press.
- Ndukwe, U. N. (2000). Achievement and retention in an expository versus project centered method of instruction in biology. *Proceeding of 23rd Annual Conference of Science Teachers Association of Nigeria*, 19(2), 136–138.
- Njoku, C. O. & Akamobi, I. (2015). Effect of Learning Activity Package (LAP) on students' academic achievement in Agricultural Science. *Journal of Pristine*, 10(1), 195-201.
- Okeke, E. A. C. (1986). Remedies for students' poor performance in science. *Proceedings of the Science Teachers Association of Nigeria*, 118–136.
- Udeji, A. U. (2007). Effects of concept mapping on secondary school students' achievement and interest in biology. Unpublished M.Sc (Ed) Thesis, ESUT.
- Ugbe, L. & Dike, V. (2012). *The comparative effect of using improvised freefall apparatus and bomb calorimeter in teaching the concept of Enthalph in Nigeria*. Calabar: Ikemfo press.



## Assessment of Safety Attitude and Awareness in Biology Laboratory among Senior Secondary School Biology Students in Zaria Educational Zone

Alafiatayo, B. M., Musa, H. R. & Nuhu, B.T  
Department of Biology  
Federal College of Education. Zaria

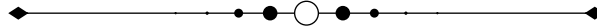

### ***Abstract***

*This study assessed safety attitude and awareness in biology laboratory among senior secondary school biology students in Zaria educational zone. This study used descriptive survey. Data was collected using SAPQ as instrument for data collection. 5,182 biology students were studied. Random sampling selected 357 Biology students in line with Krejcie and Morgan 1970 Sampling Table. Mean and standard deviation were used to answer research questions. The majority of respondents risked their lives in biology labs. The findings also showed that male and female biology students differed slightly in their mean safety awareness, although there was no significant difference between them. Males were slightly more aware than girls. The researcher recommends that the government should sponsor the science teachers to workshops and seminars organized on safety/risks of laboratories. Also, in building biology laboratory, attention should be placed on the design and location to ensure expansion and safety.*

***Keywords:*** Assessment, Safety, Attitude, Awareness, Laboratory, Educational zone

---

### **Introduction**

Science is the methodical observation and experimentation of the physical and natural worlds (Stevenson & Lindberg, 2013). According to the Science Council (2010), science is the methodical study and application of natural and social phenomena. Science education in Nigerian schools has become a societal concern. Many kids learn science by rote and find it challenging (Eyibe, 2020; Jegede, 2022). Parents, science educators, the public, and even the



government have questioned scientific education and learning (Adepoju, 2020; Ivowi et al., 2019). Since Nigerian children score low in science, scientific instruction in schools has been criticised. Nigerian pupils performed poorest in elementary science and second-to-last in secondary science in the Second International Science Study (STAN, 2022). Biology combines the Greek words "bios" (life) and "logos" (study). (Ogunleye, 2022). Science and arts students in Nigerian senior secondary schools must have it. According to Obochi (2021), teaching biology helps pupils grasp the world and acquire progressive societal abilities. It lets students apply science to everyday issues. National research and technology depend on biology (Ali, 2011). Biology covers all biological processes. Biology illuminates the world's infinite riches. To live a healthy, productive, and happy life education's ultimate goal this is needed (Ajayi, 2014). Teaching and learning biology should be hands-on because it underpins many applicable fields. Hands-on scientific activities educate the process. Biology underpins industry (Mari, 2012). It teaches students problem-solving. Biology teaches students to influence the environment for personal, family, and community benefit. Biology was made mandatory for senior secondary school students in Nigeria due to its multidisciplinary nature. Practical biology teachings are crucial. Biology labs are hands-on, mind-on, and student-centred. Students with rich backgrounds in practical courses and different laboratory equipment and facilities are thought to have higher intellectual growth (Fafunwa, 1984). Shaibu and Mari (2010) define a laboratory as a place where scientists test hypotheses with scientific equipment. Science laboratories can be any field, stream near a school, garden, or workshop outfitted and set apart for the purpose they serve (Danazumi, 2022). Biology, like other science subjects, is taught in class and practised in a safe lab to demonstrate theoretical understanding and possible new discoveries. Teachers teach science and how scientists study the world in the school lab. For safety and learning, the lab is rectangular, square, T-shaped, or semi-circular (Hofstein & Lunetta, 2014). Practical subjects require labs.

Laboratory equipment is essential to any practical project because it helps students develop long-term memory, ethical science, collaboration, active participation, scientific experiences that may help them develop scientific attitudes and skills, and an inquiry-based mindset. Laboratory activities teach manipulative and cognitive skills, according to Shaibu and Mari (2010). Most schools' laboratory activities don't allow students to develop, experiment, observe, gather, and interpret data, think, or solve problems. According to Bajah (2014), teaching science through practical practise is fun. According to Ughamadu (2012), creative use of science equipment improves student learning and performance. Abimbade (2021) stated that well-used instructional or laboratory materials boost learning, teacher competency, and student meaning. He also said that misusing these tools due to a lack of knowledge can hurt science education and learning. According to Jatau (2018), instructional equipment improves teaching and learning when teachers use it effectively. He also found that students in ecological gardens (outdoor laboratories) performed better. Students learned from natural items using ecological studies equipment.

Safety means avoiding danger. Adams and Salome (2014) define safety as "freedom from danger or risk". Every action requires safety measures. It's essential to comprehending. Lab work requires safety precautions. Teachers or students can do this. Aminu (2022) claims that strong value judgement, careful manipulation, proper supervision, and most importantly, knowledge of how to use laboratory safety devices can reduce most laboratory dangers. Unaware people are more likely to cause fatal accidents from modest hazards. Scientists learn and test hypotheses in laboratories (Archohold, 2017). Labs combine practical work and

safety. One goal of effective practical teaching in biology is to teach the public how to handle risky materials (STAN, 2014). Safety precautions for students and teachers determine the success of practical lessons and the good outcomes of secondary biology instruction (Shana & Abulibdeh, 2020). Science labs work well when teachers and students are aware of and follow laboratory safety operational guidelines. Safety awareness is the information, abilities, and attitudes lab workers can employ in any situation to keep the lab safe. On this view, the researcher is assessing the safety attitudes of students in the biology laboratory in Zaria Educational Zone.

### **Statement of the Problem**

Practical classes entail a lot of dangers that need to be managed to prevent laboratory accidents involving both students and teachers. In the scientific labs of Nigerian secondary schools, it has been seen that neither teachers nor students pay any attention to potential threats (Abimbade, 2021). They might not be aware of these risks, speak less about protecting themselves from them, or simply not give a damn. In order to prevent mishaps and the transmission of infection, both teachers and students must strictly adhere to the safety regulations when using the biology laboratories. To advance science as a discipline, it is important to understand the students' degree of understanding and their attitude towards adhering to safety regulations. Numerous incidents occur when performing practical exercises in laboratories, and the majority of students claim to be unaware of safety rules and regulations. For this reason, this study was conducted to determine whether biology secondary school students are aware of safety rules and regulations in laboratories, with the following specific purposes:

1. To determine how much biology laboratory technologist and students in senior secondary schools are aware of the risks that exist in these labs.
2. To assess the students' safety awareness and measures with gender in Biology laboratory in senior secondary schools.

### **Research Questions**

These research questions guided the study:

1. What are the level of laboratory technologists and student's awareness of risks that exist in laboratories in senior secondary schools?
2. How does Biology students' safety awareness vary with gender in Biology laboratory in senior secondary schools?

### **Hypothesis**

1. There is no significant difference in in male and female Biology students' safety awareness in Biology laboratory in senior secondary schools.

### **Literature Review**

Safety means protection from risk, injury, major physical harm, or other harm. A sane person would want to maintain it at all costs, which necessitates particular regulations and precautions in public, private, and industrial settings (Anijah-Obi, 2021). Laboratory safety depends on adequate design and user compliance with well-written safety rules. Our labs must have a fire extinguisher, a water extinguisher, a fire blanket, and a basic first aid kit. The following items should be in a first aid box for immediate treatment (Hofstein & Lunetta, 2014);

1. A single pair of blunt-tipped scissors
2. Different-sized bandages
3. A single triangle bandage
4. A tin of dressings and sticky plasters
5. A single pressure or rubber band.
6. Glucose
7. A Dettol bottle
8. A spirit bottle
9. Large dressings and sterile gauze
10. Cotton that has been sterilised
11. Sterilised eye pads in small and medium-sized untreated cottons for cuts to the hands, fingers, etc.
12. One bottle of "TCP" or an equivalent non-corrosive antiseptic.
13. Tiny forceps
14. One medical thermometer.
15. Pen contact
16. Copies of forms that must be filled in order to report first aid treatment to a doctor
17. The numbers to summon an ambulance or the school doctor

Since most accidents are caused by ignorance and carelessness, teachers should make sure students understand well-written safety standards and follow them before letting them use the lab. As summarised by Hofstein and Lunetta (2014), scientific lab employees and students must follow safety rules below;

1. Safety Spectacles: To shield the eyes from glass, dust, or chemical splash.
2. Hand Gloves: should put on gloves when moving or combining toxic, radioactive, cancer-causing, and caustic substances. Gloves may make it difficult to handle wet glass during a practical exercise and increase the risk of skin infections.
3. Safety Shoes: Lab shoes are required. Avoid injury and contamination by wearing closed-toe shoes.
4. Lab Coats: Button and fit the lab coat. Cotton absorbs more fluids and provides better chemical protection than nylon. Static electricity does not cause sparks that ignite extremely combustible organic solvents.
5. Aprons: A rubber apron and lab coat are necessary for working with chromic acid, hydrofluoric acid, and other extremely corrosive liquids.

Other rules to be observed as highlighted by Edward (2021) include:

1. Students are allowed in the lab when scheduled to work with a teacher or technologist;
2. The teacher must forbid lab joking, jesting, and unwholesome play;
3. Students should be provided rules for using experiment items. Thus, the experimenter must learn to read the reagent label;
4. Never allow a student to handle a chemical solution or anything else in a lab unless instructed to;
5. Waste, fire, and first aid must be provided;
6. Students must learn proper equipment maintenance and lab management.

### **Hazard in Biology Laboratory**

Hazards threaten life, health, property, or the environment. Physics, chemistry, and biology

labs have hazards such as chemicals, gases, electricity, and broken glass. Microorganisms, blood collection, laboratory animals, waste handling, and disposal are unique biology lab hazards (Hofstein & Lunetta, 2014). Edward (2021) lists several biology lab dangers:

1. **Sharps:** Careless handling causes cuts from sectioning razors, microtones, blades, etc. Dissecting these artefacts can introduce microorganisms into the body from contaminated cuts.
2. **Blood Sampling:** Blood sampling requires attention. To take a sample, a lancet is used to puncture the skin, making it easy for microorganisms to enter the donor's bloodstream or pollute the environment. Small cuts can spread HIV and viral hepatitis. When drawing blood, use a clean, sterilised needle. Plaster of Paris can be added and then discarded after there are enough used lancets or needles in the container.
3. **Microorganism:** Microorganisms are innocuous but can cause diseases in other environments. Culture, dissection materials, laboratory animals, and soil are the main microorganism sources. These can be inhaled, ingested, or absorbed through skin damage.
4. **Handling:** Germs can be avoided by handling and putting on protective clothing such as rubber gloves, masks, lab coats, etc.
5. **Disposal:** Disposing materials is simple. Before dumping or washing, sterilise all contaminated tools and glassware. Autoclaving or overnight soaking in a disinfectant can do this.
6. **Laboratory Animals:** Lab animals must come from reputable sources because wild animals, mammals, and birds can spread disease. They can infect lab workers and other animals. Therefore, remove lees, ticks, mites, skin fungus, and dangerous gut bacteria. Plant materials can cause wounds, allergies, and bruising for students. When handling animals, cage litter or bedding, lab workers should practise good hygiene. Even fish may scrape and bite. Wear rubber gloves and wash your hands. Maintaining anti-tetanus shots is crucial. Dispose of carcasses in opaque bags. So, seal and bury your freshly plastic bags. Infected or diseased animals' bedding must be burned in opaque bags.

Even in highly developed laboratories, there are risks. Edward (2021) studied the types of laboratory incidents that occur in Texas public schools, the contributing causes, and the degree to which the institutions complied with the most recent laboratory safety regulations. Class size was the main factor. Accidents increase with science class enrollment. After 25 students, teachers reported accidents at the same rate. This suggested that science classrooms with 25 or fewer students may prevent laboratory mishaps. The most frequent events, both major and mild ones, involved broken glass, heat burns, and foreign objects in the eyes. Electrical shock, ingestion, and damage were brought on by explosions, chemical burns, and broken equipment. In a secondary school biology lab in Nigeria, according to Olugenga (2014), there is a potential for electric sparks (10.0%), hot water spills on the body (80.0%), chemical spills (57.5%), stumbling (67.5%), falling (55.0%), cuts (75.0%), body injuries (70.0%), collapse (62.5%), fainting (15.0%), and eye injuries (30.0%).

### **Methodology**

In the chosen secondary schools in the Zaria Educational Zone, the descriptive survey method was employed to gather data for the study. The study's target audience was senior secondary school students taking biology at a particular public secondary school in the Zaria

Educational Zone, which had a total of 5,182 biology students enrolled. 357 students from four randomly chosen schools out of the 14 secondary schools in the Zaria Educational Zone make up the sample. The Krejcie and Morgan 1970 Sampling Table was utilised to select the sample. A stream of SS 2 students from each of the schools that were tested was chosen for the study, with a sample size of 357. Data were gathered using a researcher's "Safety Awareness and Precaution Questionnaire (SAPQ)" for Students and Teachers. Both components of the instrument—section A, which examined the dangers they were aware of, and section B, which assessed the protective measures they had taken—were used. Very Great Extent (4 points), Great Extent (3 points), Less Extent (2 points), and Very Less Extent (1) were the four possible responses. The SAPQ was validated by two senior lecturers and two lab assistants from Ahmadu Bello University's Science Education Department who have all had expertise teaching science. The collected data were examined using the mean and standard deviation to address the research questions by the study and t-test was used to analyse the hypothesis.

## Results

**Research Question One:** What are the level of laboratory technologists and student's awareness of risks that exist in laboratories in senior secondary schools?

Mean statistics was used to answer the research question and summary data shown in Table 1.

S/N	ITEM	$\bar{X}$	SD
1	Recognise that every laboratory activity carries a danger to your health.	3.82	1.02
2	Dust is dangerous to health	2.14	0.96
3	Smoke is dangerous to health	2.82	0.46
4	Hydrocarbons are harmful to human health	2.16	0.74
5	Health risks come from decaying substance odours	2.64	0.25
6	Gas emissions are harmful to your health	2.54	0.23
7	Burning creates a risk in the lab	3.43	1.04
8	The possibility of an explosion in a laboratory is high	2.19	0.73
9	Simple experiments using metal burning can be dangerous	2.13	0.66
10	It is harmful to not wash your hands with soap after an exercise in the lab.	3.04	1.08
	<b>Cumulative Mean</b>	<b>2.69</b>	<b>0.72</b>

According to their item means, the results in Table 1 showed that students and lab technologists have various levels of safety awareness. Laboratory technicians and students only have fair understanding of their safety in the lab and risk taken, according to the cumulative mean of 2.69 and the standard deviation of 0.72.

**Research Question Two:** How does Biology students' safety awareness vary with gender in Biology laboratory in senior secondary schools?

**Table 2: Male and Females Biology Students' Safety/Risk Awareness**

Variable	N	X	SD	Mean Difference
Male	200	70.43	5.11	
Female	157	68.53	4.98	1.90



From Table 2, the respondents' safety awareness revealed the mean value for male is 70.43 and standard deviation of 5.11 while for female is 68.53 with standard deviation of 4.98 which implies that the male have slightly higher awareness than the females. The test of significance was done in the related hypothesis.

**Hypothesis** - There is no significant difference in in male and female Biology students' safety awareness in Biology laboratory in senior secondary schools

**Table 3: T-test analysis on gender disparity towards safety awareness in Biology laboratory**

Variable	N	$\bar{X}$	SD	SE	DF	T-Value	P-Value
Male	200	70.43	5.11	0.314	356	23.018	0.064
Female	157	68.53	4.98	0.251			

Table 3 revealed the t-test analysis of gender disparity towards safety awareness in Biology laboratory. Since the p value is 0.064, this implies that the value is more than p value of 0.05. Hence the gender disparity towards safety awareness in Biology laboratory is not significant with t value of 23.018.

### Discussions of the Findings

It is not a good development that biology students only have a fair understanding of their safety, regardless of their gender or where they attend school. The results showed that biology students can run the risk of putting themselves in danger while carrying out their work, particularly in the laboratory. According to their item means in Table 1, teachers, technicians, and biology students all had various levels of safety awareness. The results confirm a study by Alhassan and Poku (2018) that found a high level of general knowledge of job dangers. The mean score on safety awareness varied marginally between male and female biology students. The study accepts that there is no significant difference towards safety awareness in Biology laboratory. This result implies that strict discipline should be maintained in biology laboratory by the teachers or the demonstrators in charge of the lab. This should be in the areas of strict compliance with the standing laboratory regulations as displayed in the laboratory, the provision of signal through alarm bells and telephones and adequate notice boards where safety rules may be prominently displayed or relayed. This research is in contrast to the findings of Meor and Syamsul (2017), who discovered that there are some variations between men and women when it comes to using safety precautions in a workshop and that women are more likely to do so since they experience higher levels of anxiety. Gyekye and Salminen (2011) also noted notable discrepancies in safety practises, noting that men and women have different characteristics, particularly in terms of alertness. It is evident from the discussion above that our biology students exposed themselves to some risk of danger or illnesses that could be harmful to their health. Additionally, this may impair their ability to learn.

### Conclusion

The importance of biology laboratory as a tool for effective teaching and learning of biology cannot be over looked. For biology laboratory to achieve its aims and objectives, it should be safe for those using it. This is the overall essence of this project work. If however, the recommendations are implemented, safety in biology laboratory will very likely be to very great extent. The study's findings suggest that biology students are generally conscious of their



safety, but more needs to be done to help them understand the risks they run while working in the labs and help them choose the best preventive measures. This will maintain their good health, which is essential for studying.

### **Recommendations**

The researcher suggested the following based on the results of the study:

1. The government should sponsor the science teachers to workshops and seminars organized on safety/risks of laboratories.
2. In building biology laboratory, attention should be placed on the design and location to ensure expansion and safety.

### **References**

- Abimbade, C. T. (2021). Effective primary school science teaching, meaning, scope and strategies in T.O. Oyetunde, Y. A., Mallam and G. A. and Zagi, U. (ed). *The Practice of Teaching, Perspective and Strategies*, 176-186.
- Adams, A. & Salome, A. A. (2014). Evaluation of safety practices in biology laboratories in selected secondary schools within Gumel Emirate, Jigawa State, Nigeria. *Creative Education*, 5, 1274-1280.
- Adepoju, J. A. (2020). *Factors and problems in the teaching and learning of mathematics in Nigerian schools*. Paper Presented at the National Curriculum Conference organized by the Federal Ministry of Education, Lagos, Nigeria.
- Ajayi, D. O. (2014). Community science: Implication of science teacher: Proceeding of the 39<sup>th</sup> Annual conference of STAN.
- Akunsoba, E. H. (2015). The secondary school chemistry teachers' perception of the goals of laboratory activities and the skills students should derive from them. *Journal of STAN*, 23(1 & 2), 116-121.
- Alhassan, R. K. & Poku, K. A. (2018). Experiences of frontline nursing staff on workplace safety and occupational health hazards in two psychiatric hospitals in Ghana. *BMC Public Health*, 18, 701.
- Ali, A. (2011). *Strategic issues and trends in science education in Africa*. Onitsha: Cape Publications.
- Aminu, D. M. (2022). Improvising of School Science Teaching Equipment. *Journal of the Science Teachers Association of Nigeria*, 20, 12-14.
- Anijah-Obi, F. N. (2021). *Fundamental of environmental education and management*. Calabar: University of Calabar Press.

Archohold, W. F. (2017). *School science laboratories, a hand book of design, management and organization*. London: John Murray.

Bajah, S. T. (2014). Continuous assessment and practical work in science teaching: A plea for pragmatism. *Journal of STAN* 20(2), 43-48.

Danazumi, B. (2022). The teaching of biology in new Nigeria policy of education. *Journal of Science Teachers Association of Nigeria*, 20(2), 74-81.

Edward, J. F. (2021). An analysis of laboratory safety in Texas

Eyibe, S. C. (2020). Effective teaching in technological education as a research activity. *Journal of Technical Education Review*, 2(2), 3-12.

Fafunwa, A. B. (1984). Science and technology development in Nigeria. A Paper Presented at the 5th Conference of the Science Teachers Association of Nigeria. Jos: University of Jos.

Gyekye, S., & Salminen, S. (2011). Organizational safety climate: Impact of gender on perception of workplace safety. *Perspectives in Psychology Research*, 61-77.

Hawkins, M. D. (2013). *Technician safety and laboratory practice*. Great Britain: The Camelot Press Ltd.

Hostein, A. & Lunetta, N. V. (2014). The laboratory in science education: Foundations for the twenty-first century. *Science Education*, 88(1), 28-54.

Ivowi, U. M., Okebukola, P. A., Oludotun, J. S., & Akpan, B. B. (2019). Raising standard of performance in public examinations in science, technology and mathematics (No. 4): Science Teachers Association of Nigeria.

Jatau, A. A. (2008). Identification of level of utilization of instructional resources among science teachers in Pankshin: *STAN 49th Annual conference proceedings*.

Jegede, O. J. (2022). *Factors enhancing meaningful learning in science*. Paper presented at the Faculty of Education seminar, Lagos State University, Ojo, Lagos - Nigeria.

Julius, S. (2013). What are three classifications of laboratory hazards? Retrieved from <http://www.ehow.com/ehow-mom/>

Krejcie, R. V. & Morgan, D. W. (1970): Determining sample size for research activities, Educational and Psychological Measurement.

Legesse, A. & Asmamaw, A. (2022). Assessment of familiarity and understanding of chemical hazard warning signs among university students majoring chemistry and biology: A Case Study at Jimma Unervisty, Southwestern Etiopia. *World Applied Sciences Journal*, 16(2), 290-299.

Meor, I. K. & Syamsul, A. M. K. (2017). Level of students' awareness of rules and safety in science laboratories. Master Project Report, Universiti Teknologi Malaysia, UTM Press.

Obinaju, W. I. (2012). Child empowerment and national development sustainability paradigms. *33rd Inaugural Lectures Series*. University of Uyo, June 28.

Obochi, M. U. (2021). Effects of problem-solving strategy on academic performance of senior secondary students in biology in Kaduna State Nigeria. *Journal of Science Technology and Education*, 9(1), 179-188.

Ogunleye, A. O. (2022). An investigation into the availability and extent of resources in the teaching of physics in some Lagos public and private schools. 47<sup>th</sup> Annual Conference of STAN 283 – 290.

Olugenga, A. J. & Thomas, O. O. (2014). Analysis of hazard and safety in science laboratories in Ekiti state, Nigeria. *British Journal of Education, Society & Behavioural Science*, 4(3), 403 – 414.

Olumide, A. O. (2022). Knowledge, awareness and compliance of postgraduate students to laboratory safety procedures. *Bioresearch Bulletin*, 4, 180-184.

Otuka, J. O. (2018). Students understanding of some concepts in physics. *Journal of the Science Teachers Association of Nigeria*, 25(2), 130-134.

Science Council (2010). Our definition of Science. Retrieved from <https://sciencecouncil.org/about-science/our-definition-of-science/>

Science Teachers Association of Nigeria (STAN). (2022). Raising the standard of performance in public examinations in science, technology and mathematics. Position paper No. 4. Ibadan: STAN.

Shaibu, A. M. & Mari, J. S. (2010). *Enriching laboratory activities in schools: Implications for the chemistry teachers*. 41<sup>st</sup> STAN Annual Conference Proceedings. 146-1478.

Shana, Z. & Abulibdeh, S. E. (2020). Science practical work and its impact on students' science achievement. *Journal of Technology and Science Education*, 10(2), 199-215

Stevenson A, & Lindberg CA. (2013). New Oxford American dictionary. Retrieved from URL: <http://www.oxfordreference.com/view/10.1093/acref/9780195392883.001.0001/m-en-us1287825?rskey=iM3YAb&result=69977&q>.

Udoh, A. O. (2023). Status of safety awareness among senior secondary school science students in Akwa Ibom State of Nigeria. *Academic Journal of Interdisciplinary Studies*, 2(2), 275-279.

Ughamadu, K. A. (2012). *Curriculum concept, development and implementation*: Onitsha: Emba publishing Company ltd.



## The Implication of Distribution Management Strategy on Customer Satisfaction (A Case Study of Transport Service Limited, Lagos State)

<sup>1</sup>Adewale Adeola Oluyemisi, <sup>2</sup>Kazeem Toyin Cynthia and <sup>3</sup>Omula Godwin G.

<sup>1&2</sup>Department of Business Administration and Management  
Federal Polytechnic Ile-oluji, Ondo State, Nigeria

<sup>3</sup>Department of Accountancy  
Federal Polytechnic Ile-oluji, Ondo State, Nigeria

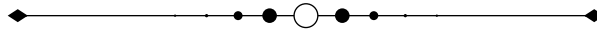

### *Abstract*

*D*istribution management is one of nowadays tools to face economic challenges; it's a mix of business and core activities of the organization. The general objective of this study was to carry out an assessment of customer satisfaction on the distribution strategy of a foremost logistics and supply chain solutions company, TSL Logistics LTD. Specifically, the study sought to examine the impact of distribution management strategy on customer satisfaction. The total number of respondents was 94. The study used questionnaires, containing open ended to obtain primary data. The questionnaires were self-administered. For research data analysis and presentation, data was collected, edited and coded to ensure consistence. The analysis of data involved more of statistical tools in the presentation of information. Simple percentages were used in qualifying the relationship in one datum to another. The chi-square technique was featured in the results aspect of the hypothesis. The study concluded that distribution management strategy and effective logistics management have active and direct role in customer satisfaction. Based on the research findings, the study recommends that Transport Service Limited Company should focus on customer satisfaction by adopting appropriate distribution management strategies. Also, the study recommends that Transport Service Limited Company should choose a distribution strategy that best satisfies their customers. Furthermore, the study recommends that a combination of more than one distribution management strategy should be adopted by Transport Service Limited. This will help to improve the service provision to the customers.

**Keywords:** *Distribution management, Logistics, Transport services, Customer satisfaction*

---

## **Introduction**

Since the beginning of “customer service revolution” almost 25 years ago, business research has focused on customers, especially customer satisfaction. Business consultants, corporations and operational management have all worked together to identify the characteristics of organizations that consistently please their customers, to develop tools that monitor customer satisfaction, and to build continuous quality improvement systems that respond to consumer feedback. As industries engage in production of goods and services, they need to make them available to consumers at the right time right place and at the least cost (price). All these cannot be without effective and efficient system put in place. Distribution management refers to the process of overseeing the movement of goods from supplier or manufacturer to point of sale. It is an overarching term that refers to numerous activities and processes such as packaging, inventory, warehousing, supply chain and logistic (Adam, 2022). A distribution management system also makes things easier for the consumer. It allows them to visit one location for a variety of different products. If the system didn't exist, consumers would have to visit multiple locations just to get what they need. Distribution management is the process used to oversee the movement of goods from supplier to manufacturer to wholesaler or retailer and finally to the end consumer. Having a successful distribution management system is also important for businesses to remain competitive and to keep customers happy (Adam, 2022). Effective distribution is so crucial that sub-discipline practices became an integral part of supply chain and inventory management, such as just in time inventory. Overall, successful distribution involves many moving parts and methods requiring a strong distribution management strategy fuelled by real-time information (Lisa Schwarz, 2022). For example, a company that produces breath mints may distribute to grocery stores, gas stations, vending machines and other popular retail locations. Using the intensive distribution strategy can help improve brand awareness, expand into new markets and acquire new customers (Indeed Editorial Team, 2023). This research aims to enlarge the debate concerning the different distribution management strategies implemented by industrial companies to increase customer satisfaction and to determine their impact. In particular, this research, by means of semi-structured interviews, aims to identify and propose new links between distribution management strategy theory and customer satisfaction.

## **Statement of the Problem**

Distribution management has long been a business challenge. Raw goods can arrive too early and go bad before they are used or finished products can arrive too late, allowing a competitor to seize the lion's portion of market share (Lisa, 2022). The importance of distribution management strategy has been neglected in favour of other marketing functions. Manufacturers, however often forget the fact that the only marketing function that links the consumer and the products produced is the distribution network. TSL Company has in the past received bad publicity regarding costly delay in the delivery of supplies- a package that comes late equals one unhappy customer who can potentially vent their anger on social media; a delayed delivery opens up the possibility of customers asking for refunds and compensation (Ewa, 2021) and its reputation dented because of inconsistent customer service and also due to operational inefficiencies. This has led to its decline in performance. The core mandate of TSL Company is to ensure timely and efficient distribution of goods and services from source to the last mile. However, despite a lot of resources being invested, delivery of goods and services has not billed up to the required local standard, it therefore emerges that distribution management procedures adopted by TSL Company have an effect on customer satisfaction in



terms of timely distribution of goods. It is against this backdrop of challenges in distribution and transportation that this study aims to determine how these distribution practices affect customer satisfaction.

### **Literature Review**

Aayushi (2022) defined distribution management as the process of managing the flow of products from supplier to manufacturer to wholesaler or retailer to final customer is known as distribution management. There are numerous procedures and activities involved, including as packaging, managing raw material vendors, warehousing, inventory, supply chain, logistics. According to Melissa Sonntag (2020), distribution strategies depend on the type of product being sold, the trick is knowing what type of distribution you will need to achieve your growth goals. There are three methods of distribution that outline how manufacturers choose how they their goods to be dispersed in the market.

1. Intensive Distribution: The goal of intensive distribution is to penetrate as much of the market as possible.
2. Selective Distribution: Select outlets in specific locations. This is often based on a particular good and its fit within a store. Doing this allows manufacturers to pick a price point that targets a specific market of consumer, therefore providing a more customized shopping experience.
3. Exclusive Distribution: Limited outlets. This can mean anything from luxury brands that are exclusive to special collections available only in particular locations or stores. This method helps maintain a brand's image and product's exclusivity.

Distribution management not only increases profitability but also reduces waste in a variety of ways, from less spoilage to lower warehousing expenses since items and supplies can be distributed as needed rather than stored in larger quantity. Distribution control results in less shipping charges. Additionally, it facilitates “one-stop shopping” and other conveniences and benefits like customer loyalty reward schemes, which makes things simpler for buyers. Distribution challenges can arise from a variety of disruptions. Natural disruptions include severe weather events, raw material shortages (e.g. bad crop years), pest damages, and epidemics or pandemics. Human disruptions include riots, protests, wars and strikes. Transportation disruptions include transport vehicle disrepair, maintenance downtimes and accidents, as well as delayed flights and restrictive or new transportation regulations such as those regularly seen in trucking. Economic challenges include recessions, depressions, sudden drops or increases in consumer or market demands, new or changes in fees or compliance costs, changes in currency exchange values and payment issues. Product disruptions include product recalls, packaging issues and quality control issues. Buyer disruptions include order changes, shipment address changes and product returns.

According to Lisa Schwarz (2020), Many things can influence distribution management. The five most common are:

1. Unit perishability: If it's a perishable item then time is of the essence to prevent loss,
2. Buyer purchasing habits: Peaks and troughs in purchasing habits can influence distribution patterns and therefore varying distribution needs that can be predicted,
3. Buyer requirements: E.g. changes in a retailer's or manufacturer's just in time inventory demands,
4. Product mix forecasting: Optimal product mixes vary according to seasons and weather or other factors and



5. Truckload optimization: Relies on logistics and fleet management software to ensure every truck is full to capacity and routed according to the most efficient path.

### **Distribution Management Strategy and Customer Satisfaction**

Distribution management is primarily concerned with planning every step necessary to deliver items to the consumer on time and with the least amount of waste possible. Jochen (2022) posits that distribution management strategy helps to improve the way customers interact with your business, leading to customer satisfaction and repeat business. It can also help you streamline your business to make it more efficient. Through a more efficient business and improved customer satisfaction, this strategy can lead to higher profits. Good and timely distribution will help a company to retain its customers because with good distribution, customers will be satisfied and will be loyal to the company so that the company will survive and exist in business activities. While customer service involves an interaction with the customers, distributions deals with tangible products. The better the company is a distribution, the better the customer service and satisfaction becomes. Inflation causes businesses to increase their prices in order to make a profit.

### **Research Methodology**

#### **Research Design**

This study adopted a descriptive survey design. A descriptive survey research was adopted because of its ability to consolidate both qualitative and quantitative data. A descriptive survey was appropriate for the study because structured and semi structured responses can easily be collected (Blumberg et al.,2014). According to Mugenda and Mugenda (2012), a descriptive research design provides a valid and accurate representation of factors and variables, which pertain to the research questions.

#### **Sample Frame and Technique**

The sampling frame for the study comprised of the members of staff and customers of Transport Service Limited Company in Lagos, Nigeria (Ikoyi & Mushin branch). For easier collection of data and analysis, a sample size was randomly selected for the study based on convenience.

#### **Test of Hypotheses**

The Pearson Fisher chi-square was adopted in the test of hypotheses. The chi-square formula is stated thus,

$$X^2 = \sum \frac{(o_i - e_i)^2}{e_i}$$

Where  $X^2$  = Chi-square

$\sum$  = Summation sign

$O_i$  = Observed frequency

$e_i$  = Expected frequency

### **Data Analysis and Presentation**

#### **Test of Hypothesis 1:**

$H_{01}$ : Distribution management strategy does not have a significant impact on customer satisfaction.

**Distribution management strategy has a significant impact on customer satisfaction**

Responses	Frequency	Percentage
Strongly agree	52	55
Agree	31	33
Undecided	5	5
Disagree	4	4
Strongly disagree	2	3
<b>Total</b>	<b>94</b>	<b>100</b>

Source: Field survey, 2023

Constructing the statistics, we have

RESPONSES	O <sub>i</sub>	E <sub>i</sub>	(O <sub>i</sub> - E <sub>i</sub> )	(O <sub>i</sub> - E <sub>i</sub> ) <sup>2</sup>	(O <sub>i</sub> - E <sub>i</sub> ) <sup>2</sup> /E <sub>i</sub>
Strongly agree	52	18.8	33.20	1102.24	58.63
Agree	31	18.80	12.20	148.84	7.92
Undecided	5	18.80	-13.80	190.44	10.13
Disagree	4	18.80	-14.80	219.04	11.65
Strongly disagree	2	18.80	-16.80	282.24	15.01
<b>Total</b>	<b>94</b>				<b>103.64</b>

The calculated value = 103.64;

The degree of freedom, n-1  
= 5-1 = 4 (degree of freedom)

The level of significance = 0.05

The critical value at 4 degree of freedom and 0.05 level of significance is 9.49

The calculated or chi-square value (103.64) is greater than the critical value (9.49).

**Decision Rule:** Reject the null hypothesis and accept the alternative hypothesis if the calculated value is greater than the critical value; otherwise the reject the alternative hypothesis.

**Decision:** Since the calculated value (103.64) is greater than the critical value (9.49), the researcher accepted the alternative hypothesis which states that Distribution management strategy has a significant impact on customer satisfaction.

**Test of Hypothesis 2:**

H<sub>01</sub>: There is no significant relationship between effective logistics management and customer satisfaction.

**Effective logistics management has a significant degree of relationship with customer satisfaction**

Responses	Frequency	Percentage
Strongly agree	49	52
Agree	40	43
Undecided	3	3
Disagree	1	1
Strongly disagree	1	1
<b>Total</b>	<b>94</b>	<b>100</b>

Source: Field survey, 2023

Constructing the statistics, we have

RESPONSES	O <sub>i</sub>	E <sub>i</sub>	(O <sub>i</sub> - E <sub>i</sub> )	(O <sub>i</sub> - E <sub>i</sub> ) <sup>2</sup>	(O <sub>i</sub> - E <sub>i</sub> ) <sup>2</sup> /E <sub>i</sub>
Strongly agree	49	18.80	30.20	912.04	48.51
Agree	40	18.80	21.20	449.44	23.91
Undecided	3	18.80	-15.80	249.64	13.28
Disagree	1	18.80	-17.80	316.84	16.85
Strongly disagree	1	18.80	-17.80	316.84	16.85
<b>Total</b>	<b>94</b>				<b>119.40</b>

The calculated value = 119.40;

The degree of freedom, n-1

$$= 5-1 = 4 \text{ (degree of freedom)}$$

The level of significance = 0.05

The critical value at 4 degree of freedom and 0.05 level of significance is 9.49

The calculated or chi-square value (119.40) is greater than the critical value (9.49).

**Decision Rule:** Reject the null hypothesis and accept the alternative hypothesis if the calculated value is greater than the critical value; otherwise, the reject the alternative hypothesis.

**Decision:** Since the calculated value (119.40) is greater than the critical value (9.49), the researcher accepted the alternative hypothesis which states that there is a significant relationship between effective logistics management and customer satisfaction.

### Discussion Based on Hypothesis One

Distribution management strategy has a significant effect on customer satisfaction. The statement was confirmed to be true in the comparison of the researcher's findings with the empirical review. The evidence is shown in the calculated value (103.64) which is greater than the critical value (9.49). Jochen de Peuter-Rutten (2022) posits that distribution management strategy helps to improve the way customers interact with your business, leading to customer satisfaction and repeat business. It can also help you streamline your business to make it more efficient. Through a more efficient business and improved customer satisfaction, this strategy can lead to higher profits.

### Discussion Based on Hypothesis Two

Effective logistics management has a significant relationship with customer satisfaction. The statement was confirmed to be true in the comparison of the researcher's findings in the empirical review. The evidence is shown in the calculated value (119.40) which is greater than the critical value (9.49). Apteian (2019) opined that the logistics activities within a business organization attempt to satisfy customers through achieving the time and location related market challenges and also through the cost of the service provided as well as the quality, taking into consideration customers' needs and purchase power.

### Summary, Conclusion and Recommendations

#### Summary

The general objective of this study is to examine the implication of distribution management strategy on customer satisfaction. This study employed primary data which involved the utilization of structured questionnaire. Each section of the questionnaire contained five-

point rating scale (Likert scale), starting from strongly agreed (SA), agreed (A), and undecided (UN), disagreed (D), and strongly disagreed (SD). The population of this study comprised of 123 with the sample size of 94. Two branches of Transport Service Limited in Lagos State (Ikoyi & Mushin). The Pearson Fisher chi-square was adopted in the test of hypotheses. From tested hypothesis one, the calculated value (103.64) is greater than the critical value (9.49) and from the decision rule, it was concluded that the alternative hypothesis should be accepted which states that distribution management strategy has a significant effect on customer satisfaction. From tested hypothesis two, the calculated value (119.40) is greater than the critical value (9.49) and from the decision rule, it was concluded that the alternative hypothesis should be accepted which states that there is a significant relationship between effective logistics management and customer satisfaction.

### **Conclusion**

In this study, a sample of 2 main branches of Transport Service Limited with 94 respondents was used. Based on the findings above the study concludes that distribution management strategy influence customer satisfaction in TSL Company. The study further concludes that there is a significant relationship between effective logistics management and customer satisfaction.

### **Recommendations**

Based on the research findings, the study recommends that Transport Service Limited Company should focus on customer satisfaction by adopting appropriate distribution strategies. Also, the study recommends that Transport Service Limited Company should choose a distribution strategy that best serves their customers. Further, the study recommends that Transport Service Limited Company should use a combination of more than one distribution strategy. This will help to improve the service provision to the customers.

### **References**

- Aayushi, S. (2022). Distribution management: Definition, advantages, disadvantages & strategies: *Global Journal of Marketing*
- Adam, H. (2022). *Distribution management: Definition, how it works and advantages*. Dotdash Meredith Publishers
- Ewa, K. (2021). Distribution management and consumer behavior. *An international Journal of operational Research*, 532(7), 223-245.
- Gunasekaran, A., Patel, C. & Tirtiroglu, E. (2018). Performance measures and metrics in a supply chain environment. *International Journal of Operations and Production Management*, 21(1/2), 71-87.
- Gunasekaran, A., Patel, C. & Mcgaughey, R. E. (2020). A framework for supply chain performance measurement. *International Journal of Production Economics*, 87(3), 333-347.

Jobber, U. (2020). The effects of retailer supplier chain technology mandates on supplier stock returns. *International Journal of Physical Distribution and Logistics Management*, 39(10), 814-825.

Jochen de, P. (2022). *Course on service innovation by design*. EHL Campus: Laussane.

Khan, M. S., Naumann, E. & Williams, P. (2019). Identifying the key drivers of customer satisfaction and repurchase intentions: An empirical investigation of Japanese B2B services. *Journal of Consumer Satisfaction, Dissatisfaction and Complaining Behavior*, 25(3), 159-178.

Lindsey, J. (2020). The dimensions of distribution management strategy. *International Journal of Consumer Satisfaction and Distribution Management*, 35(8), 369-390.

Lisa, S. (2022). *Distribution management: Definition, advantages and strategies, global product marketing*.

Markus, F. (2020). Determinants of distribution intensity. *The Journal of Marketing*, 39-51.

Sharma, A., Grewal, D., Levy, M. (2020). Customer satisfaction/logistics interface. *Journal of Business Logistics*, 16(1), 14-21.

Study Corgi. (2020, October 10). *Supply chain management theories*. Retrieved from <https://studycorgi.com/supply-chain-management-theories/>

Wilson, C. (2021). Forward integration into distribution: An empirical test of transaction cost analysis. *Journal of Law, Economics, & Organization*, 4(2), 337- 355.

Zhang, Q., Vonderembse, M. A. & Lim, J. S. (2017). Logistics edibility and its impact on customer satisfaction. *International Journal of Logistics Management*, 16(1), 71- 95.



## Assessment of 1kVA Solar Powered Inverter for Residential Application

<sup>1</sup>Opeke Ebenezer and <sup>2</sup>Amudaniyu Aliyu Temitope

<sup>1,2</sup>Department of Electrical/Electronic Engineering, School of engineering  
Federal Polytechnic Ile-oluji, Ondo State, Nigeria

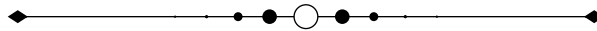

### **Abstract**

*The project comprises of a Solar panel, Inverter, Charge Controller and a Battery. It employs step by step methods for the design and construction of the Inverter having an Oscillator and MOSFET stages, MOSFET, IRFP150N was used in the power stage. The constructed unit was tested and assessment was carried out on it. An Analyzer Meter was used to determine the efficiency of the system. This project can serve as an alternative means of power supply thus eradicating epileptic power supply in the country.*

**Keywords:** *Assessment, 1kVA solar powered inverter, Residential application*

---

### **Introduction**

#### **Background of the Project**

Day by day, the sun shines and beams on the earth more than enough to satisfy global needs. A solar module is the technology that harnesses solar energy from the sun. An inverter converts the direct current (D.C) into alternating current (A.C). Today, many people are familiar with so-called solar panel which can be found on rooftop and overhead tank. The cells are made of semiconductor materials, when sunlight strikes the cells, electrons loose from their atom, as they flow through the material, and they generate electricity in form of direct current which is used in charging the batteries that power the inverter unit. And inverter can produce square wave or pure sine wave which can be used to power our home's appliances. Electricity is a form of energy that is produced in various ways. Electricity plays vital roles in human's lives starting from the way man gets food and shelter. Electronics devices depend on electricity to perform their tasks, this make it necessary to have efficient power supply. Solar energy is not a new thing. Its history span from the 7<sup>th</sup> century BC till to today, we started out concentrating on the sun's heat with glass and mirror to light fire. In 1767, Swiss physicist, Alpine explorer and aristocrat horacede sanssur was credited with invented the first working solar oven, among other discoveries. Constructed from 5 layers of glasses and measuring around 12 inches across. The oven worked by allowing lights to pass through the glass before being absorbed by



the black lining and turned into heat. The heat is then reflected by the glass, therefore heating the space inside the box up to 87.5 degree Celsius (Owen, 1996).

### **Statement of the Problem**

The main problem that brings up the construction of this project is the epileptic power supply in our houses which prevent us from constantly usage of domestic appliances.

### **Purpose of the Project**

To design and construct 1kVA stand-alone solar powered inverter.

To assess a 1kVA stand-alone solar powered inverter.

### **Significant of the Project**

Solar inverter is useful in making appliances works at residential level, industrial level and schools:

1. Solar inverter helps in saving money that would have used to fuel a generator
2. It's reduces the costs associated with generating electricity
3. Solar inverter can work at night time when there is no sunlight when their battery is charged fully during the daylight

### **Scope of the Project**

The solar inverter converts direct current DC generated by the batteries into alternating current AC to feed home appliances. The solar inverter consisted of solar panel, charge controller, inverter and rechargeable batteries.

### **Literature Review**

According to Olajuyin and Olubakinde (2017), multiple solar panels can be wired both in parallel and series to increase current capacity and to increase voltage respectively; in which smaller wire sizes are used to transfer electric power from solar panels array to the charge controller and the attached batteries to favor the use of higher voltage output. This design helps to reduce the challenges of power supply at all time, as energy is stored up during the day via charging of the battery and the stored-up energy is used up when needed as an alternative source of energy supply when supply from national grid fails without affecting the integrity of the battery (Ekwuribe & Uchegbu, 2016). This is made possible via the solar panels that generates solar energy from the sun and convert it to electricity with the aid of individual silicon cells gotten from the solar panels.

### **Charge Controller**

A charge controller is a voltage and current regulator which is used to keep batteries from overcharging. It regulates the voltages and current coming from the solar panel going to the battery. Most of 12volt solar panel put out 16V to 20V so if there is no charge controller for regulation, the batteries will be damaged from overcharging because most of the batteries need 14V to 14.5V to get fully charged.

### **Solar Panel**

A solar panel is those devices which are used to absolve the sun's ray and convert them into electricity or heat. The solar panel is a collection of solar cells (photovoltaic), which can be used to generate electricity through photovoltaic effects. These cells are arranged in a grid like pattern on the surface of solar panels.



**Figure: 1** Solar Panel

**Deep Cycle Battery**

A deep cycle battery is the type of battery designed to have a high depth of discharge. This means it can release high amounts of stored electricity compare with its storing capacity. A deep cycle battery is also built for fast recharge and provides steady stream of power over a long period of time. It is designed to produce steady power output over an extended period of time.



**Figure 2:** The Battery

**Inverter**

An inverter is a power electronics device or circuitry that changes direct current DC to alternating current AC. The inverter turns the direct current coming from the battery into alternative current can be using to power our home appliances.

**Oscillator**

An oscillator is an electronics device or circuit that is used to produce a periodic waveform or oscillating electronic signal. Oscillator converts a steady state DC signal into periodic AC signal of desire frequency determined by the characteristics of the circuit components.

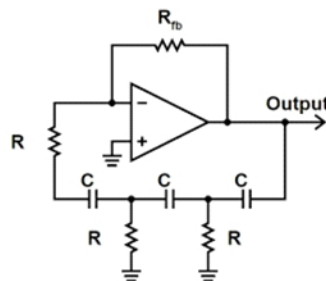

**Figure 3:** Oscillator Circuit Diagram

**Transformer**

A transformer is a device that transfers electrical energy from one alternative current to one or more other circuit, either increasing (stepping up) or reducing (stepping down) the voltage. Transformer change voltage level through electromagnetic induction as the magnetic line of force (flux) build up and collapse with the change in current passing through the primary coil and current is induced in another coil called this secondary.

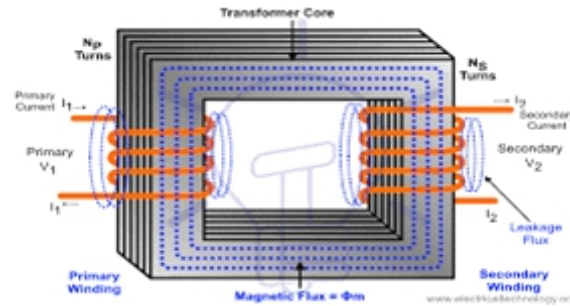
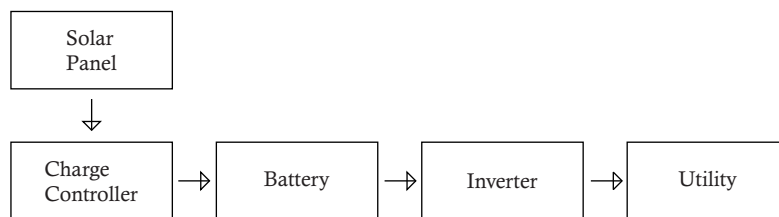

**Figure 4:** Showing the Transformer

**Methodology**

**System operation with block diagram**

The solar panel absorbs energy produced by the sun and converts it into electrical energy. It does this by absorbing the sun rays into the modules of the solar panel hence produced free electrical charge carriers in the conduction and valence bands. The electricity produced by the solar panel was then transferred to the charge controller as shown in fig: 5 below. The charge controller regulates the rate at which electric current go into battery. It turns off charge when the battery reaches the optimum charging point and turns it on when it goes below a certain level. It fully charges the battery without overcharging it. The batteries were the key component in this solar power system.



**Figure 5:** The Solar Powered Inverter Block Diagram

**Oscillator**

SG3524 incorporate all the functions required in the construction of a regulating power supply, inverter, or switching regulator on a single chip. It can be used as the control element for high-power-output applications. SG3524 was designed for switching regulators of polarity, transformer-coupled dc-to-dc converters, transformerless voltage doublers, and polarity-converter applications employing fixed-frequency, pulse-width modulation (PWM) techniques.

### Electrical Characteristics of SG3524

**Table 1: Showing the SG3524 Specification Datasheet**

Parameter	Value
Part number	SG3524
Control method	Voltage
V <sub>in</sub> (min) (V)	8
V <sub>in</sub> (max)(V)	40
Frequency (max)(kHz)	722
Duty cycle	45
Gate drive (max)(%)	0.05
Operating temperature range (oC)	0 to 70
Short circuit current(mA)	100
V <sub>out</sub> (V)	4.5 to 5.4

### Principles of Operation

The SG3524 is a fixed frequency pulse-with-modulation voltage regulator control circuit. The Regulator operates at a frequency that is programmed by one timing resistor (RT) and one timing capacitor (CT). RT established a constant charging current for CT. This results in a linear voltage ramp at CT, which is fed to the comparator providing linear control of the output pulse width by the error amplifier. The SG3524 contains an on-board 5V regulator that serves as a reference as well as powering the SG3524's internal control circuitry and is also useful in supplying external support functions. This reference voltage is lowered externally by a resistor divider to provide a reference within the common mode range the error amplifier or an external reference may be used. The power supply output is sensed by a second resistor divider network to generate a feedback signal to error amplifier. The amplifier output voltage is then compared to the linear voltage ramp at CT. The resulting modulated pulse out of the high-gain comparator is then steered to the appropriate output pass transistors (QA or QB) by the pulse-steering flip-flop, which is synchronously toggled by the oscillator output. The internal circuit of the SG3524 is shown below

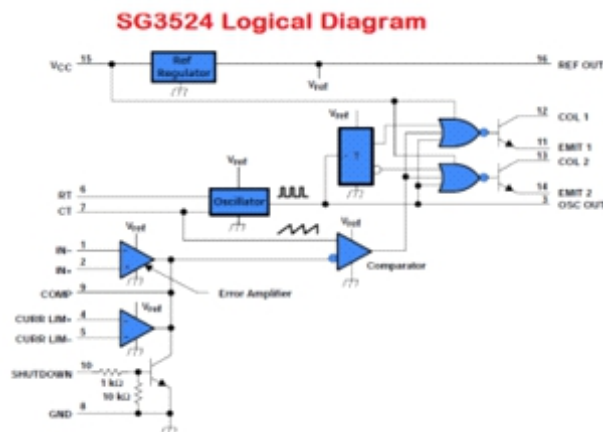

**Figure 6: The Internal Circuit of SG3524**

### Construction of the Circuit

To generate the oscillating signal that controls the switching ON and OFF of the gate of an 8-numbered MOSFETS linked in parallel to a center-tapped transformer, this circuit uses IC SG3524 PWM as an oscillator and IRFP250N as a switch. This connects the 12V DC from the battery to the transformer's windings, producing a 230V AC at 50Hz frequency suitable for residential appliances with a maximum power rating of 1kVA.

### Calculation of Frequency

$$F = \frac{1.3}{RT \times CT}$$

Where: CT = 0.1μF

F = 50Hz

RT=?

$$50 = \frac{1.3}{1 \times 10^{-6} \times RT}$$

$$1.3 = 50 \times 1 \times 10^{-6} \times RT$$

$$1.3 = 5 \times 10^{-6} \times RT$$

$$RT = \frac{1.3}{50 \times 10^{-6}} = 260000$$

$$RT = 260K\Omega$$

CT Has a tolerance of 5%

$$\frac{5}{100} \times 0.1 \times 10^{-6} = 5 \times 10^{-9}$$

To obtain the tolerance

$$CT_{MAX} = 0.1 \times 10^{-6} + 5 \times 10^{-9}$$

$$CT_{MAX} = 1.05 \times 10^{-7}$$

$$CT_{MIN} = 0.1 \times 10^{-6} - 5 \times 10^{-9}$$

$$CT_{MIN} = 9.5 \times 10^{-9}$$

$$\frac{1.3}{1.05 \times 10^{-7} \times 50} = 247619.04 = 250KD$$

$$RT = \frac{1.3}{9 \times 10^{-8} \times 50} = 273684.212 = 300K$$

Therefore, for selecting RT variable resistor between the ranges of 250k to 300k can be selected and varied during operation to obtain 50Hz or 60Hz. But it is important to understand the fact that all 1 watt variable resistors have plus or minus tolerances their specification and by selecting 220k variable resistor the oscillator will work within the range.

To calculate RT range for 220k

$$\frac{30}{100} \times \frac{220000}{1} = 66000$$

$$RT_{MAX} = 220000 + 66000 = 286000$$

$$RT_{MIN} = 220000 - 66000 = 154000$$

Therefore, it is best to use 230k (since it covers capacitor tolerance range or 247619.04 and 273684.21) and adjusted to obtain 50-60Hz frequency.

### Driver Stage

The third-generation power MOSFET from Vishay which provide the designer with the best combination of fast switching, ruggedize design, low on resistance and cost effectiveness is IRFP150. This power MOSFET can be used in a modified sine wave power inverter to oscillate (switch) with 50Hz frequency, the 50Hz alternating signal from pin 11 and 14 of the 1C operate each MOSFET channel separately. This results in the MOSFET channel being alternatively on and off, switching process is repeated 50 times per second (according to the definition of frequency) the drain (middle pin) of all the MOSFET of one channel are connected together but insulated from the heat sink which absorbs the heat dissipates in the circuit. The gate of each MOSFET are connected via resistor (1 K $\Omega$ ) to the oscillator output signal, the resistors limit the pulses going into the gates, another resistor of 10K is connected between the gates and the source in order to prevent the MOSFET from false triggering. The source terminal of the MOSFET of both channels connected together to the ground. Because the polarity of the 50Hz MOSFET drives signals are different, only channel from the output remain on at a time, the other channel stays off.

MOSFET Current Design Calculation

$$\text{Current rating} = \frac{1000}{12} = 83.33A$$

Therefore, the current rating per channel is

$$\text{current per side} = \frac{83}{2} = 41.67A$$

Having three identical MOSFET, the required current rating for each of the MOSFET will be

$$\frac{41}{3} = 13.87A$$

Hence 6 MOSFET OF 41A was used with 3 on each side of the channel.

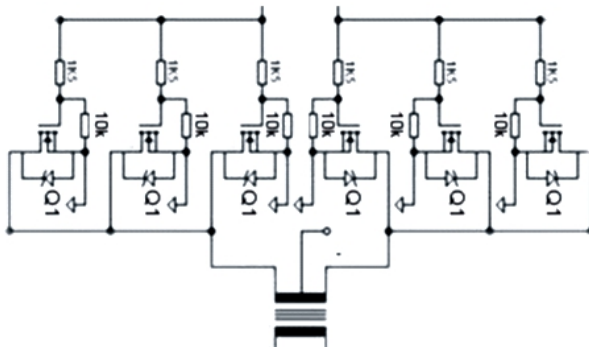
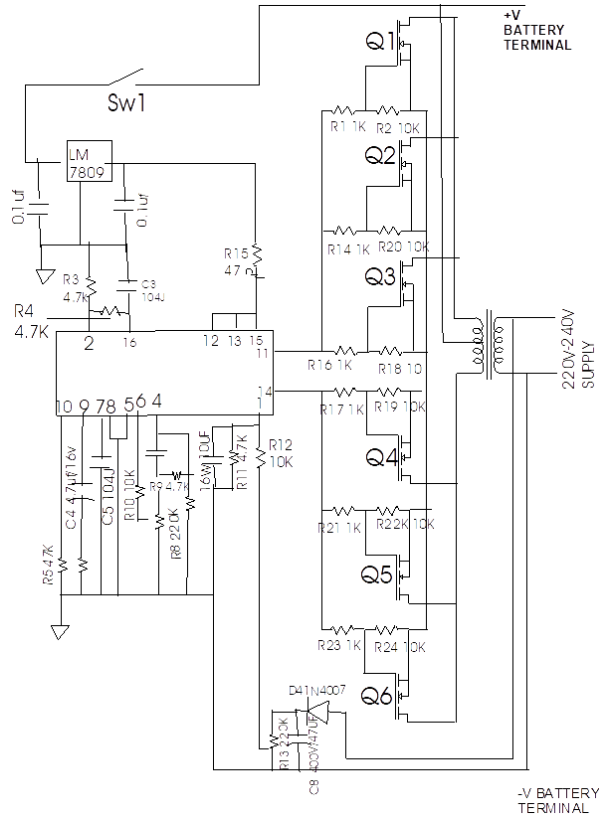

Figure 7: Showing the Arrangement of the MOSFET



MOSFET are connected in parallel to increase the power within the circuit.



**Figure: 8** The Circuit Diagram

**Transformer Design**

The transformer is a device that alternating current from one voltage level to another. It has no rotating parts. It works on the principle of mutual induction. Transformer needs two coils which are wound on a laminated core. These coils are called primary coil and secondary coil. One of the important parts of the inverter is the transformer. The rating of the transformer designed is 2000VA. The normal input voltage for normal operation is 12 D.C and the expected output is 240V A.C. The size of the coil used in the primary windings was gauge 20 and for the secondary side of the transformer was gauge 18.

**Table 2: Showing Transformer Specifications**

Input voltage	12V
Output voltage	230V
Power rating	1kVA
Frequency	50Hz
Phase	Single

**Core Size**

To determine the size, the dimensions of the laminated core was measured and from the measurement taken, the core size was calculated as shown below;

Core cross sectional area (cm<sup>2</sup>)

$$A = L*B = 4.5*5.5 = 24.75\text{cm}^2$$

Let B (flux density) = 0.72T

$$\Phi_m = BA$$

Where A is the core cross sectional area

$$\Phi_m = 0.72*24.75*10^{-4} = 0.01782$$

Volt per turn

$$E = 4.44f \Phi_m N (N=1)$$

$$E = 4.44*50*0.001782 = 0.4\text{V/Turn}$$

$$N_1 = \frac{V_1}{E} = \frac{220}{0.4} = 550 \text{ turns}$$

$$N_2 = \frac{V_2}{E} = \frac{12}{0.4} = 30 \text{ turns} \times 2$$

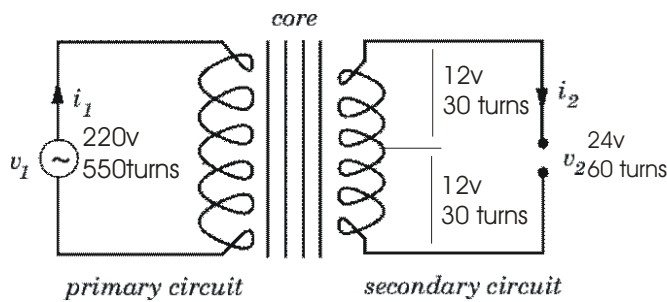

**Figure 9:** Showing the Transformer Circuit Diagram

$$P=IV$$

$$I_1 = \frac{P}{V_1} = \frac{1000}{220} = 4.35\text{A}$$

$$I_2 = \frac{P}{V_2} = \frac{1000}{12} = 83.33\text{A}$$

**Battery**

The Backup Time (BUT) and the Load to be connected determines the size of the Battery. But for the purpose of this project a 12V, 100AH deep cycle battery was used, so to get the battery size to be used we assumed our estimated hours of usage to be 8 hours same hours estimated for the solar panel sizing

For this, Battery backup time can be determined using this formula:

$$\text{Backup time (BUT)} = \frac{\text{Battery rating} \times \text{battery voltage}}{\text{Load in watt}}$$

Let assume the total load is 500w, battery rating to be 12v, 100AH

$$\text{Therefore} = \frac{100 \times 12}{500} = 2.4 \text{hrs}$$

Charging Time of the Battery

$$\text{Hour taken to fully charge} = \frac{\text{energy}}{\text{solar panel power}}$$

Where  $P = IV$

$$P = 100 \times 12 = 1200 \text{WH}$$

Rate of the solar panel = 150w

$$\text{Hours to get fully charge} = \frac{1200 \text{WH}}{150} = 8 \text{hr}$$

Therefore, for a rated solar panel of 150W charging a battery of 100AH needs 8hrs to get fully charged

### Charge Controller

Ampere rating of the battery charge controller

$$P = IV$$

$$I = \frac{P}{V}$$

Where: P = the power rating of the solar panel

I = charging current of the charge controller

V = the voltage of the battery

Parameters: P = 150W, V = 12V

$$I = \frac{150}{12} = 12.5 \text{A}$$

Therefore, the ampere rating of the charge controller is 12.5A. 100AH is the total capacity of the battery, if 83A is drawn from it

$$\text{Therefore: } \frac{100 \text{AH}}{83 \text{A}} = 1.2 \text{Hr}$$

Note: if 83A draw from the battery, the battery will only last for 1.2Hr.

### The Enclosure Construction

This is also the parts of our construction and it was done by us, the design dimensions are shown below

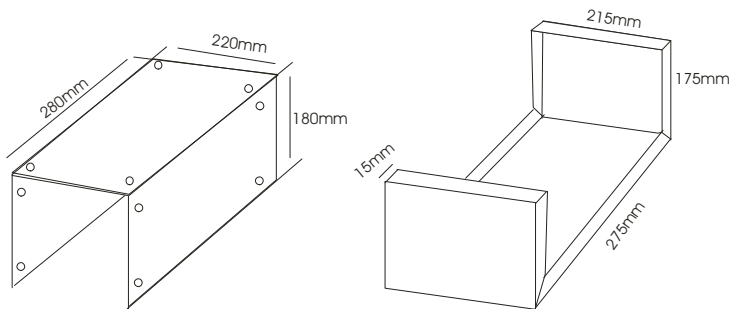

Figure 10: Inverter casing

The vent hole and screw holes were bored by using hand drill. The case dimensions picked considered the fact that we wanted enough space that is adequate for the components it is going to house and also for proper ventilation. We used a suction method of cooling in that the fan sucks the air, so cool air flows in through the vents on both sides which regulate the temperature within the case.

**Assembling**

The circuit board being ready and the casing is available, this stage involves the fixing in the components into the casing. First in was the transformer and it was screwed in the hole drilled for the transformer, then the circuit board and every other things followed-indicator, fan, fuse, etc of which after everything as in place, proper connections were made and soldered, it was covered and screwed together. The finished work is shown below.



**Figure 11:** Showing Inverter Constructions

**Testing, Result and Analysis**

**Testing**

Table 3: Equipment's (load in watt) used for testing the 1kva Solar Inverter for Resistive, Capacity and Inductive Load.

S/N	Equipment's loads specification	Equipment power rating (watt)	Recording End Time
1	20 AKT bulbs of 25w each	500w	1:40 - 1:45
2	4 ceiling fans of 70watt each and 10 AKT bulb of 25watt each	530w	1:46 – 1:51
3	10 ceiling fan of 70watt each	700w	1:52 – 2:00

Battery power rating = 12volts, 100 ampere per hour

The table 3 above shows the various load subjected to the inverter and their corresponding time interval.

**Conclusion**

The construction of 1kVA, 220V solar inverter at a 50Hz frequency was carried out and the goal of the project was to generate 1000 watts of electricity to serve as alternative source for residential application. The initial cost of construction of solar inverter was relatively high

compare with similar source of energy supply but it has very small or no maintenance cost. Various tests were carried on the project, such as low cut-off battery stage test, oscillator stage test and inverter efficiency by loading it with various load capacity. The result of the various test shows that the solar inverter is perfectly working and can be used to power the entire resistive load within its capacity.

### **Problems Encounter**

During the construction of this system, there are problems which came in the way of achieving the design goals of this project which is later rectified. One of the problems was the disarrangement in the MOSFET connection, and also delays in fabrication of the casing. We also encounter another problem when winding our transformer, at the point of winding the secondary side, we made the secondary voltage to be 0-12 instead of 12-0-12 center tapped which lead us to dismounted the transformer to double the number of turns in that secondary side of the transformer in order to give us expected output voltage (12-0-12 center tapped).

### **Recommendation**

The inverter cannot be used to power any device of higher power rating. I also recommend this topic as a project is a good idea and it comes at the right time this particular topic should also be given to other students both in higher and lower class.

### **References**

- Abiodun, G. (2017). What is solar power inverter system. Retrieved from [www.Academia.Edu](http://www.Academia.Edu)
- Akpan, E. (2015). Inverter Make use of a solid state and electromechanical relay for automatic switching of load. Retrieved from [www.Wikipedia.Com](http://www.Wikipedia.Com)
- Flavin, C. (2013). Renewable energy. Retrieved from [www.Sunpower-Uk.Com](http://www.Sunpower-Uk.Com)
- Faludy, T. (2013). *Retractable awning with integrated solar cell*. New York: Carefree Scoot Fetzer Co
- Olabiyi, B. A., & Oroye, O. A. (2020). Design and construction of 2kva solar- power inverter. *Journal Of Engineering And Applied Science*.
- Olajuyin, E. A., & Olubakinde, E. (2018). Design of 2kva solar inverter. *Scientific Research Journal*.
- Olusegun, O. O., Segun, O., O. & Taiwo, R. O.(2014). Design and construction of 1kw (1000va) power inverter. *Innovative Systems Design And Engineering Journal*.
- Owen, G. (1996). Origin of Inverter. IEEE Industry Application Magazine: History Department (IEEE).
- Rodriguez, J. (2002). Multilevel inverter: A survey of topologies, controls and application. IEEE Transaction on Industrial Electronics (IEEE).

Uchegbu, F. (2016). Energy stored in the battery during the day can be used at night when there is no sun. *Journal of Renewable Energy*.





# Principles and Practice of Cooperation in the Context of Universal Application Among Cooperatives in Nigeria

**Mudasiru Olawale Ibrahim**  
*Cooperative Economics and Management*  
*Federal Polytechnic, Ile Oluji, Ondo State, Nigeria*

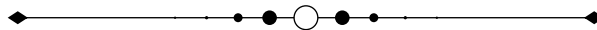

## *Abstract*

*This paper understudied the development of cooperative principles globally and the context of how they are localized among cooperatives in Nigeria. There were no significant variations in the activities of the Cooperatives understudied and the stated ICA 1995 Principles save for “cooperation among cooperatives” and “education, training and information” of the general public about the benefit of cooperatives. Observations from this study were that although, cooperative societies understudied had their laws tailored to many of the ICA Principles 1995, they have minimal association with secondary and tertiary cooperatives in and outside their local area. The need for formal education of Staff and Executives of these cooperative societies was recommended. Likewise, the need for cooperatives to intensify information to the public about the benefit of cooperatives.*

**Keywords:** *Principles, Practice, Rochdale, Values, Cooperatives, Cooperation, Universality*

---

## **Introduction**

Cooperation around the world had been translated to different meanings and context where inherent socio-economic conditions among cultures and social system impacts on what cooperation stands for. According to Holmen (1990), the umbrella term 'cooperation' covers a wide range of particular forms, experiences and objectives. Chilokwu (2014) had noted that cooperation and self-help are universal principles of human social organization. Therefore, it is rare that cooperation and self-help would not be found in every society and culture.

Mutual co-operation and self-help have stood out as time tested organizational principles for carrying out a variety of functions such as farming, house construction and repairs, maintenance of roads, savings and credit mobilization; and the provision of various communal projects in traditional African society. In Nigeria, cooperation and self-help were

exhibited in traditional associations like savings and credit associations seen in “isusu” among the Igbo and “ajo” among the Yoruba. Also, cooperation manifested in traditional labour groups and age grades as practiced among the Hausa as “gayya” and “aro” among Yoruba. Therefore, “Cooperation” is natural. Melis and Semmann (2010) noted that cooperative behaviour is a widespread phenomenon between individual of same and different species. Hence, Cooperation among people is normal. Although, cooperation in all facet is as old as man himself, but it is different from cooperatives.

Aihonsu and Idowu (2022) noted that modern cooperatives developed from the traditional cooperation. Therefore, it is pertinent to know what modern cooperatives stands for. This is because defining cooperatives in the contemporary world had left a gap between the “essentialist approach” of defining cooperatives and the “nominalist” approach. In order to put to rest the cross criticisms between the two approaches, the International Cooperative Alliance in 1995 had defined Cooperative as “autonomous association of persons united voluntarily to meet their common economic, social and cultural needs and aspirations through jointly-owned and democratically-controlled enterprise”. Cooperatives were created long before fair trade movement to help workers improve their livelihoods and protect their interests (Wilhoit 2005). Therefore, the methods of the early cooperative societies seemed outdated in comparison to the new, modern cooperatives in the recent global village. Like any other organization, cooperatives too have principles and guidelines that shape their activities and businesses; hence, Merriam-Webster Dictionary had defined principles as “rules or code of conduct”; while the Oxford English Dictionary defined principles as “a fundamental truth or proposition that serves as the foundation for a system of belief or behaviour or for a chain of reasoning”. Langmore (1997) had asserted that cooperatives are based on values and principles. Cooperative values and principles seemed to be articulated such that they both drive each other. Majee and Hoyt (2011) defined Cooperative Values as general norms that cooperators, cooperative leaders and cooperative staff should share which should determine their way of thinking and acting. Cooperative principles on the other hand are guidelines by which values are put to practice. These principles rest on a distinct philosophy of the society. Therefore, cooperative societies tend to tailor their principles on attendant factors that are peculiar to their local communities. Although, there exist the resolve to make cooperatives adhere to the same principles globally, however, cooperatives in different parts of the world have diverted from the declared cooperative principles in various directions. Fairbairn (1994) asserted that between 1930s and 1960s there were radical changes to cooperative movements and what they stand for. Some of the attributable conditions were decolonization and growth of cooperatives in the developing countries where new kinds of cooperatives with different structures sprang up. Therefore, there was the need to understudy the development of cooperatives in the contemporary world in the context of their compliance to global principles of cooperatives.

### **Statement of the Problem**

Growth of cooperatives has transcended all facet of the economy and sectors. With this growth comes attendant issues about strict adherence to basic and global values of cooperation. Given these values and principles, the question about the adherence to this university of values and principles is rife. With the stress on the universal application of cooperative principles as set by the International Cooperative Alliance in 1995, the problem lies in application of these principles in the activities of various cooperatives. Cooperatives and quasi-cooperatives have generally not been permitted to operate in accordance with the

'international cooperative principles', but that is not a problem in many African countries. Many African governments have adopted the 'International Cooperative Principles' as the official guide-line for their cooperative organizations (Holmén 1990). Therefore, the problem lies not in the law, but to what degree are cooperatives in Nigeria willing to adopt and adhere to these "international principles". The registration processes for cooperatives in Ondo State involved the inclusion of almost all the principles as declared by International Cooperative Alliance. However, the abundant presence and volume of cooperatives in Ondo State did placed doubts on the authenticity that these principles are being practiced and that they do not exist only in the bye – laws of these cooperatives. Hence, this research seeks to compare the gap between these principles and how they are being put into practice.

### **Objectives of the Study**

This study seeks to compare the activities of cooperatives in Ondo State to the stated cooperative principles and cooperative identity statement as issued by the International Cooperative Alliance in 1995 and how they are localized and practiced. In furtherance, this study seeks to ascertain the degree of dispersion of cooperatives from the set minimum of these principle; as oftentimes, principles do not perfectly translate to practice.

### **Theoretical Framework**

#### **Development of Cooperative Principles**

There exist various school of cooperative thoughts with different theories and ideologies about what cooperatives are. Holmen (1990) asserted that despite highly diverging ideological and theoretical perspectives among these different schools, they refer to the same set of 'basic cooperative principles'. Although, Hasselman (1971) noted that the Rochdale Society set principles of self-reliance and democracy as its tenet, other four principles were influenced by Robert Owen's ideas if not copied. These were: sale of only pure and clean goods, collection of a surplus, refunds in proportion to the use made of cooperative services and acceptance of a limited interest on invested capital. Also, strict rules of equity among members were maintained. Religious and political neutrality in addition to cash trading were stressed. Also, promotion of education was emphasized. Hence, the modern cooperative principles emanated from those principles propounded by the Rochdale Society in 1844. Despite the growth of the Rochdale Society, these principles and what they stood for were maintained. Changes in principles formulated at different period were built on the ones formulated in 1844. The principles formed in 1937 were the same as that of 1844, except that they were divided to essential and non-essential. While open membership, democratic control, surplus distribution in the proportion of patronage and limited interest on capital were viewed to be essential, cash trading, political/religious neutrality and promotion of education were viewed to be non-essential.

Holmen (1990) noted that by the late 1950s, the International Cooperative Alliance was aware of the need for the review of the cooperative principles. He noted that a commission appointed in 1963 to clear up confusion and remove unnecessary rigidity rooted in unbalanced or over-simplified interpretations of the 1937 Principles. They came up with a new list that articulated the four key points of 1937 Principles raised the status of co-operative education that was tagged non-essential to be equal to the first four, and added a new principle of co-operation among co-operatives. The ICA Congress in 1966 viewed the Cooperative Principles as universal and inseparable principles with equal authority and they should be observed in their entirety by all cooperatives. There might be other kinds of principles that apply to a

cooperative but the basic six approved by the Congress formed the minimum that a cooperative must adopt and abide by (Fairbairn 1994). Therefore, the universal application of the principles set in 1966 was emphasized by the International Cooperative Alliance. As at 1992, several levels of principles were proposed which hinged on basic values of co-operatives; basic ethics for co-operative organizational culture; and basic principles in the sense of relevant guidelines for co-operative organizations. The other which was Basic Global Values, was intended to provide more concrete, action-oriented expression of the cooperative basic values with a view to the global values being incorporated into long-term co-operative programs. The 1966 ICA statement reflects his basic principles fairly well, however, the main changes were recommended on the nature and role of capital (Book 1992). Hence, Book (1992) recommended to ICA that co-operative principles be sorted out into cooperative principles and co-operative practices, with the former being formulated in the most universal possible way, and the latter being drawn up in different forms appropriate to each branch or sector of co-operation. The Manchester Congress of ICA in 1995 declared the Cooperative Identity Statement which incorporated the definition of Cooperatives, their values and stated principles.

According to ICA (1995), the Cooperative Identity Statement sought to define Cooperatives as autonomous association of persons united voluntarily to meet their common economic, social, and cultural needs and aspirations through a jointly-owned and democratically-controlled enterprise. The Statement further stated that Co-operatives are based on the values of self-help, self-responsibility, democracy, equality, equity, and solidarity. In the tradition of their founders, co-operative members believe in the ethical values of honesty, openness, social responsibility and caring for others. The Principles were voluntary and open membership, democratic member control, member economic participation, autonomy and independence, education, training, and information; co-operation among co-operatives and concern for community.

### **Review of Literature**

The methodologies used by many researchers who had worked on the principles of cooperatives were empirical. Fairbairn (1994) in his work asserted that attempt to create principles guiding the cooperative business of the Rochdale Society was hinged on the fact that the Society had pragmatic economic purposes within the context of an activist working-class culture and a visionary ideological outlook. He further noted that Rochdale Society had their statutes, laws and principles. The laws were taken from the Statutes and the principles were taken from both. He noted that the Statutes formed in 1844 was the foundation for the methods and principles of the Rochdale Society, many things left out by the statutes were later included in the Rochdale Principles. His assertion was that co-operative theorists have rearranged the Rochdale principles; some previous ones issued in 1860 had been subtracted, some new ones articulated and added, while more explanations were given and the question of the values and ideals behind the principles were broached. Johnston (1997) noted that the period between 1844 and 1850 saw a giant leap in the activities of the Rochdale Society; hence by 1860 the Society had realized the need to be passive in some of its principles. Religious and political differences which by then had been apparent in the Society was not meddled with, rather the emphasis was on a common bond to join together the means, the energies, and the talents of all for the common benefit of each. Hence, between 1860 and 1895 when International Cooperative Alliance was formed, the Rochdale Society had been global. The London International Congress in 1895 and the one in Paris a year after indeed gave rise to the



formation of ICA. As Roy (1999) studied the formation of Rochdale Society and concluded that it formed an impetus for the formation of International Cooperative Alliance. He noted that as co-operatives attempted to build international structures, they were faced more and more often with the question of what makes a co-operative and that the period between 1890 and 1910 saw changes in the principles of cooperatives. He noted that by 1916, different challenges to the nature and identity of co-operatives arose from political forces. He noted the impact of Russian revolution of 1917 on the ideals of ICA many principles in Communist were not in tandem with the Communists ideas. He noted that the problem was rife since Soviet cooperatives were by then paying almost half of the ICA's income.

### **Research Questions**

The questions that this study seeks to answer are:

1. Do cooperatives in Ile Oluji follow the global principles set by International Cooperative Alliance in 1995?
2. Are the global principles easy to practice among cooperatives in Ondo State?

### **Methodology**

The methodology used in this research work is explorative. The study used cross sectional data from personal interview of the Executives and focus group discussion (FGD) with some randomly selected members of the cooperatives in Ondo State. The interview and FGD guides were translated into the local languages of the respondents in order to gather accurate responses to the questions. This study was conducted in Ondo State, Nigeria which consists of 18 local governments divided into three senatorial districts. The population for the study are cooperative societies that are registered with the State government. Stratified and random sampling techniques were used as follows: Two local governments were selected in each senatorial district for study. Two cooperatives from the six local governments were selected randomly for the FGD, while six members from each cooperative were randomly selected to participate. Samples for the interview were drawn from two cooperatives each from the six local government area with four members randomly selected from each cooperative. Therefore, the proposed sample prior to the field work was 150 for FGD and 75 for interview. However, the researcher could only interviews 48 executives; 18 who were females and 30 males. While due to the difference in the meting periods of the cooperatives, 100 members could be held in discussion, with each discussion groups having between 5 and 8 persons. The interviews were conducted on a one-on-one basis with the cooperative executives not allowed to participate in the interview and FGD at same time.

### **Findings and Discussions**

#### **Demographic Features**

Among the forty-eight interviewees, nine participants have been executives in the cooperatives for more than five years, while twenty-five have been executives between two and five years and ten of them who are within one year. The majority of the interviewees are male (62.5%) while females accounted for 37.5%. The Demographic features of selected members of the selected cooperatives had 58 male participants which represented 58% of the members of the focus groups; while females were 42 which represented 42%.

		Years spent as executive			Total	
		0 – 1 year	2 – 4 years	5 years and above	Number	percentage
Gender	Male	10	14	6	30	62.5
	Female	4	11	3	18	37.5

*Demographic Features of Cooperative Executives*

The demographic characteristics of the hundred (100) members of the differently selected members of the cooperative societies in Ondo State are shown in table 2 below:

		Years spent as member			Total	
		0 – 1 year	2 – 4 years	5 years and above	Number	Percentage
Gender	Male	10	18	30	58	58
	Female	14	11	17	42	42

*Demographic Features of Members of differently selected cooperative societies*

### Interview and Focus Groups Discussion Results

Question	Interview Response		Group Response	
	Number n = 48	Percentage	Number n = 100	Percentage
1. <b>Open and Voluntary Membership</b> a. Coop is open to all persons willing to accept the responsibilities of membership, without gender, social, racial, political, or religious discrimination.	48	100	100	100
2. <b>Democratic Member Control</b> a. Policies and decisions are by members on a democratic process.	48	100	90	90
3. <b>Member Economic Participation</b> a. Members contribute equitably to, and democratically control, the capital of their co-operative. b. Surpluses are allocated rative, possibly by setting up reserves, part of which at least would be indivisible; benefiting members in proportion to their transactions with the co-operative; and supporting other activities approved by the membership	48	100	100	100



4. <b>Autonomy and Independence</b> a. Co-operatives are autonomous and controlled by their members.	48	100	85	85
5. <b>Education, Training, and Information</b> a. Co-operatives provide education and training for their members, elected representatives, managers, and employees so they can contribute effectively to the development of their co-operatives. b. Co-operatives inform the general public - particularly young people and opinion leaders - about the nature and benefits of co-operation.	21 22	43 45	46 48	46 48
6. <b>Cooperation Among Cooperatives</b> a. Co-operatives serve their members most effectively and strengthen the co-operative movement by working together through local, national, regional, and international structures.	23	47.9	40	40
7. <b>Concern for Community</b> Co-operatives work for the sustainable development of their communities through policies approved by their members.	48	100	95	95

*Results of interviews and FGD*

## Discussion

The results showed that There were no significant variations in the activities of the Cooperatives understudied and the stated ICA 1995 Principles save for “cooperation among cooperatives” and “education, training and information” of the general public about the benefit of cooperatives where the cooperatives could not fully explore the opportunities in forming formidable networks between them. As shown in table 3, 43 percent of interviewed respondents and 46 percent from the focal group affirmed that the education and training of executives, members and staff were adequate; while 45 percent interviewed respondents and 48 percent from the focal group affirmed that the information rendered to the public about the benefits of cooperative were adequate. Observations from this study were that although, cooperative societies understudied had their laws tailored to many of the ICA Principles 1995, they have minimal association with secondary and tertiary cooperatives in and outside their local area.

## Conclusion and Recommendation

This study recommends that formal education of Staff and Executives of cooperative societies was recommended. Likewise, there is the need for cooperatives to intensify information to the public about the benefit of cooperatives.

Also, cooperatives should explore the opportunities to serve their members most effectively and strengthen the co-operative movement by working together through local, national, regional, and international structures.

## References

- Aihonsu, J. O. Y. (2014). Factors affecting loan repayment performance among members of cooperative thrift and credit society in Yewa North Local Government Area, Ogun State, Nigeria. *Greener Journal of Agriculture*, 6(4), 238 -244.
- Böök, S. Å. (1992). Co-operative values in a changing world: Report to the ICA Congress, Tokyo, October 1992, ed. Margaret Prickett and Mary Treacy. *Geneva: International Cooperative Alliance*.
- Chilokwu, I. D. (2014). *Readings in cooperative economics and management*. (2nd ed., 5-8) Cepta Nigeria Limited, Enugu.
- Fairbairn, B. (1994). The meaning of rochdale: Rochdale pioneers and the co-operative principles. *Occasional Paper Series, Centre for the study of Cooperative, University of Saskatchewan*.
- Holmen, H. (1990). State, Cooperatives and Development in Africa. *The Scandinavian Institute of African Studies, Uppsala*
- Melis, A. P. & Semmann, D. (2010): How is human cooperation different? *Philosophical Transactions of the Royal Society B*. retrieved January 7, 2022 from [royalsocietypublishing.org](http://royalsocietypublishing.org)
- Wilhoit, J. (2010). Cooperatives: A short history. *Cultural Survival Quarterly*



## The Significance of Accounting Records in Small Scale Businesses in Nigeria

<sup>1</sup>Omula Godwin G., <sup>2</sup>Kazeem Toyin Cynthia and <sup>3</sup>Adewale Adeola Oluyemisi

<sup>1</sup>Department of Accountancy

Federal Polytechnic Ile-oluji, Ondo State, Nigeria

<sup>2&3</sup>Department of Business Administration and Management

Federal Polytechnic Ile-oluji, Ondo State, Nigeria



### **Abstract**

**T**his study was carried out to determine the contributions of accounting records in efficient performance of small-scale business. Two hypotheses were formulated in line with the objectives of the study. Survey method was adopted and data were collected through the use of questionnaire. Data generated were analyzed with means, standard deviation and weighted value and the hypotheses formulated were tested using Z-test statistical technique. The study found The training of accountants by these institution and the various professional institutes should focus more on practical means of solving accounts reporting needs of small and medium scale enterprises; and that government should provide adequate financial assistance, this is because if there is adequate financial support, more unemployed Nigerians will engage in small scale enterprises thereby gaining their means of living easily than looking for unavailable while collar job. The researchers recommend that the training of accountants by these institutions and the various professional institutes should focus more on practical means of solving accounts reporting needs of small and medium scale enterprises; and that government should provide adequate financial assistance, this is because if there is adequate financial support, more unemployed Nigerians will engage in small scale enterprises thereby gaining their means of living easily than looking for unavailable while collar job.

**Key words:** Accounting records, Small scale business, Efficient performance

---

## **Introduction**

Comparatively, most of Small Scale Businesses (SSBs) are not registered as corporate bodies but as sole proprietorship, this makes registration procedures quite simple and a bit easier than the other forms of business registration. Partly due to this phenomenon, SMEs has outnumbered all the other forms of business and could be found almost everywhere across the country. In spite of their numbers, and significance, recent studies show that 60% of the SSBs fail within the first five years of operation (Boachie- Mensah & Marfo-Yiadom, 2005). Studies also show that it is hard for the SMEs to access finances from the financial institutions since they lack proper financial records as a requirement (William, 2008). The SMEs inability, many times to live beyond their first few months of existence has been attributed partly to lack of finance. To become successful and be able to contribute meaningfully to the Nigerian economy, SMEs must attract and secure finance all by themselves (Amoako, 2013). In most industries, comparability will be affected by size. Larger firms will be able to avail themselves economic and certain sophisticated quantitative management techniques that may not be practicable for small ones. Smaller companies may be able to maintain closer client relation and better customer relation than the larger ones. This difference in operation technique may influence deficit in accounting method employed in generating financial information, (Abdulrasheed, Khadijat & Oyebola, 2012). Among the different principles that firm may employ are different inventory techniques, depreciation method, method of accounting for income taxes and revenue recognition procedures. Pacioli (1494) described in approach developed by Italian merchant to account for their activities as owner and managers of business as the basic accounting model that is used up to this day. As economic activities progressed from the fundable to agriculture continued to adapt to the need of the society. As business unit becomes more complex and broader on scope, accounting evolved in response to the increased planning and control responsibilities of management. As government grows in size and becomes more centralized, accounting was developed to meet the increased accountability. It is often stated that business decisions need to be supported by good and quality financial information which needs to be relevant, user friendly and available in a timely manner, (Abdulrasheed, Khadijat & Oyebola, 2012). Where appropriate accounting should be an active steering tool to run and manage a business instead of representing another administrative burden that the sole proprietor has to comply with. It is important that the accounting systems for one man businesses should fulfill such functions as providing essential financial information for the owners and managers in order for them to be able to manage the business in a competitive environment and to make informed decisions to prevent business failure and to expand the business. However, owners of one-man businesses may have particular needs and conditions, so that accounting systems need to be flexible in order not to impose unnecessary operative burdens. (Abdulrasheed, Khadijat & Oyebola, 2012).

However, many new business owners are daunted by the mere idea of bookkeeping and accounting. But in reality, both are pretty simple. Keep in mind that bookkeeping and accounting share two basic goals: to keep track of income and expenses, which improves chances of making a profit, and to collect the financial information necessary for filing various tax returns. There is no requirement that records be kept in any particular way. As long as records accurately reflect the business's income and expenses, there is a requirement, however, that some businesses use a certain method of crediting their accounts: the cash method or accrual method. Depending on the size of the business and amount of sales, one can create own ledgers and reports, or rely on accounting (Williams, Haka, Bettner, & Carcello, 2008).

An accounting system records, retains and reproduces financial information relating to financial transaction flows and financial position. Financial transaction flows encompass primarily inflows on account of incomes and outflows on account of expenses. Elements of financial position, including property, money received, or money spent, are assigned to one of the primary groups, that is, assets, liabilities, and equity. Within these primary groups each distinctive asset, liability, income and expense is represented by respective "account". An account is simply a record of financial inflows and outflows in relation to the respective asset, liability, income or expense. Income and expense accounts are considered temporary accounts, since they represent only the inflows and outflows absorbed in the financial-position elements on completion of the time period (Williams, Haka, Bettner, & Carcello, 2008). The impact of accounting is a function of the benefit that are derived by the members of the society who had bind themselves into the social organization of their survival and want satisfaction quest (Anyigbo 1999). Business benefit from availability of accounting information, equality important is the availability of accounting that facilitates the solution or resolution of business planning, organization and control function of the enterprises as a social organization. Most small scale firm owners prefer to recruit unskilled personnel especially clerical and accounting staff. The product of these unskilled accounting (clerical staff) has only succeeded in helping the small scale firms to stagnate; some firms have even wound up. This was because unskilled accounting staff could not keep reliable accounting records that would stand the test of time statutory; such staff could not correctly determined the profit or loss of the firm preparing profit and loss account. (Onaolapo & Adegbite, 2014).

The place of sound accounting and internal control systems in any business, irrespective of its scale, cannot be overemphasized. A vast majority of small-scale businesses cannot afford the complexity of a detailed accounting system even if they would have. Hence, the existence of single entries in their books and in some cases on incomplete records (Wood, 1979; Onaolapo, et al., 2011). Audits of small scale enterprises have proven to be among the most worrisome for professional accountants because of the inadequacy of the internal controls. Except for statutory demands, small and medium scale enterprises hardly give serious thoughts to the process of sound accounting, yet the inadequacy and ineffectiveness of accounting processes have been responsible for untimely collapse of a host of them (Mukaila & Adeyemi, 2011). The level of book keeping and accounting in one man businesses have created many problems against the effective operation and accountability of a sole proprietorship. One man business suffers disproportionately from the regulatory burden compared to large companies, since the smaller enterprises often do not have sufficient financial and human resources to manage their obligations in the most efficient way. (Abdulrasheed, Khadijat & Oyebola, 2012). Meanwhile, a number of small scale enterprises have not given much attention to book keeping in relation to their business transaction, despite its importance in the success of businesses. This could be lack of sound knowledge in book keeping practices by owners or respective managers. Also, there was difficulty in ascertaining whether there is a comprehensive accounting record that satisfied the laws under which it was incorporation. (Onaolapo & Adegbite, 2014).

It was hard to determine to what extent no adherence to laid – down accounting procedure and constituted in the wheel of implementation of good accounting system. Difficult exist in ascertaining how far non – recognition of the necessity of accounting to continued existence and growth, low educational background of owners and the employment of unskilled accounting staff had affected the production of unreliable accounting or financial statement.



Because of the importance of appropriate accounting information for owners and managers of one man businesses and their different stakeholders, it is therefore important to this study to assess the impact of accounting systems applied in small scale businesses in Nigeria.

This study therefore seeks to assess the essence of keeping accounts in Small Scale Business in Nigeria. Specifically, the followings will achieve;

1. To ascertain the extent to which small scale business keep accounts of their financial transactions.
2. To ascertain the extent accounting records keeping contributes in efficient performance of small scale business.

### **Theoretical Framework**

Some aspects of the existing research delve into the relationship between record keeping and performance of firms. Tanwongsvat and Pinvanichkul (2008) comment on the reasons why SMEs prepare financial statements, and argue that on the list, SMEs rank assessing profitability second to the purpose of tax returns. According to Cooley and Edwards (1983), owners of SMEs consider profit maximization as the most important financial objective. This has led to the argument that SME owners pay attention to profitability and measurement of net profit when are evaluate their firms performance. Holmes and Nicholls (1998) concludes that the extent of accounting practices in SMEs depend on a number of factors such as age of business, size of the business, and the nature of the industry. They further point out that most SME owners and managers engage public accountants to prepare required information. According to Ismail and King (2007), the development of a sound accounting system in SMEs hinge on owners' level of accounting knowledge and skills. Some authors have argued that small businesses use professional accounting firms for preparation of annual reports and for other accounting needs (Keasy & Short, 1990; Bohman & Boter, 1984). Lalin and Sabir (2010), reports that the main drivers why SMEs prepare financial statements is pressure from regulatory authorities. Hussein (1983) notes that, a good accounting system is not only judged by how well records are kept but by how well it is able to meet the information needs of both internal and external decision-makers. Clute and Gitman (1980) uphold that it is common for qualified accountants to do a good job of keeping records up to date but they fail to provide information needed by decision-makers. Interestingly, however, others argue that the high cost of contracting professional accountants has left SME owners with no better option but to relegate management of accounting information (Evaraert et al., 2006; Jayabalan & Dorasamy, 2009). Zhou (2010) has proposed the use of accounting software to improve accounting practices, albeit he laments the unavailability of medium-sized software for SMEs

Accounting procedure is specific method of account. Fitzgerald et al 2006 argue further that business enterprises must improve production if they are to effectively compete in this era of rapid economic and technical change. Improved productivity requires both capital investment as well as a work force that has the flexibility to acquire new skills for newly created jobs resulting from structural changes in the economy. Bititei et al (2001) asserts that performance is a result of workers because they provide the strongest linkage to strategic goals of the business enterprise, Customer satisfaction and economic contribution that affects the business, hence it addresses the mode in which an activity is accomplished in particular and the level of standards to which a task is carried out within the working environment. According to Ikechukwu (1993), keeping records is crucial for the successful performance of a business. A comprehensive record keeping system makes it possible for entrepreneurs to develop accurate and timely financial reports that show the progress and current condition of



the business. With the financial report generated from a good recordkeeping system, performance during one period of time (month, quarter or year) with another period can be compared. An accurate record of the business' financial performance is vehicle to monitor performance in specific areas. Accounting records provide a basis for complete and accurate income tax computation, a basis for sound planning for the future and basis for discussion with partners, potential investors, and lenders all these are important aspects which enhance performance of the business. Business also depends on correct accounting records to make good decisions about the firm. Decision such as expansion, drop or maintain decisions of product lines, make or buy decisions, about size of debtors. Therefore, if proper records are kept they will facilitate efficient, proper timely decision making and enhance performance in small scale industry. Accounting procedure is programmatic, more numeral than principle and more susceptible to change, they often represent alternative way of applying the same principle (Zoubi & Al-Khazali 2011).

Determining the scale of operations and structure of small or medium scale enterprises is crucial. Among the notable indicators are independent management (independent of any other party, except from the owners) mostly dominated by the sole proprietorships, partnerships and private limited company. But Nigerians favour "one-man" business for lack of trust. Most small/medium scale enterprises are located in the interiors of the nation. Flexibility of administration is another important feature of small/medium scale enterprise. This has greatly enhanced their productivity and profitability because administrative bottlenecks are totally absent. Adaptability to customers' needs enhances competitiveness. (Olatunji, 2000; Aremu and Adeyemi, 2011) Other considerations include organizational manpower, limit on capital investment, annual turnover, management structure, as well as the assessment of size of particular enterprises. (Olatunji, 1995; Safiriyu, 2012) explains the relativity of such descriptions. Section 351 (1) of CAMA 1990 describes the small company as "a private company having a share capital; the amount of its turnover for the year in question should be a maximum of #2 million, or such amount as may be fixed by the commission; the net assets value is not more than #1 million; none of its members is alien, government or a government corporation; the directors should hold at least 5% of its equity shares capital. The National Economic Reconstruction fund (1989) defined small scale enterprises are those with fixed asset other than land but inclusive of the cost new investment not exceeding #10 million. The Central Bank of Nigeria (2004), defined a small scale enterprises "as one whose capital investment does not exceeding N5 million (including land and working capital) or whose turnover is not more than #25 million annually.

In the bid to increase its share of world's industrial production (about 25%) by the year 2000 and (about 40%) by the year 2010 as recent world industrial production statistics show, developing economies are increasingly focusing small and medium scale businesses (Okafor, 1999; Akwaese, 1987) the united Nations industrial development organization (UNIDO, 1980). It has been discovered that lots of small and medium scale enterprises shut down before they can achieve their goals a result of poor management arising from inadequate weak and undependable accounting and financial information. (Olatunji, 2000; Safiriyu, 2012). In 1990 budget, the Federal Government of Nigeria defined small scale enterprises for the purpose of commercial loan as those enterprises with annual turnover not exceeding N500, 000 and for merchant loan as those for the purpose of commercial loan as those enterprises with capital investment not exceeding N 2 million (excluding cost of land or a maximum of N5 million). According to Umar (1997) the concept of the small size firm is a relative one and it depends

mainly on both the geographical location and the nature of economy activity being performed. According to LeGrand et al (1992) and Schubert (1994) they perceive poverty as either absolute or relative or both. Absolute poverty being that which could be applied at all time in all societies, while relative poverty relates to the living standards of the poor to the standards that prevail elsewhere in the society in which they live. Englama et al (1977) also defined poverty in both absolute and relative terms as a state where an individual is not able to cater adequately for their basic needs of food, clothing and shelter. Lacks gainful employment, skills, assets and economic infrastructures such as education, health, potable water, and sanitation, and as a result has limited chance of advancing his/her welfare to the limit of his/her capabilities.

World development Report (1990) used an upper poverty line US \$ 370 income per capital as a cut off for absolute poverty. People whose consumption level falls below that level are considered poor and those below US \$ 275 as very poor. Obadan (1997) sees poverty as a situation of low income or low consumption. Some researchers also defined it as inability to meet basic material needs encompassing food, water, clothing, shelter, education, health as well as basic non-material needs including participation, identity, dignity, etc. (Blackwood & Lynch 1979). As a result of flexibility nature of small-scale enterprises, they are able to withstand adverse economic role since they are more of labour intensive. Therefore, they have lower capital costs that are associated with job creating (Anheier & Seibel, 1987; Schmitz, 1995). Small scale enterprises has been defined variously by many individuals and institution using various yardsticks such as numbers of employees, volume of sales, value of assets, or the volume of deposit in banks (Ademola et al 2012). The National Economic Reconstruction Fund (NERF) defined small and medium enterprises with a criterion that projects to be financed by the firm should have a total fixed asset cost (including land) of not more than N10million. The Federal Ministry of Industry (in respect of the small scale industries credit scheme) sees small scale industry as any manufacturing, processing or service industry with capital investment not exceeding N150,000 in machinery and equipment alone.

According to Atijosan (1998), a small business is any manufacturing, processing or servicing industry that satisfies any or all of the following conditions:

1. Capital, but excluding cost of land and not excluding N750,000
2. Staff strength not exceeding 50 persons and wholly Nigerian owned.
3. A manufacturing, processing or servicing industry, exceeding the units of investment stated is relatively small compared to prevalent size of plant and the technology is fairly labour intensive.

According to Ademola et al (2012), Small scale enterprises are catalysts for world's economic growth and development which have dominated the industrial sector of both developed and underdeveloped countries. Aruwa (2006) believed that Nigeria's industrial sector is dominated by small and medium scale enterprises (SMEs) which accounts for 90% in terms of number of enterprises, as compared with other developed countries where more than 98% of all their enterprises belong to SME sector, about 80% of the total industrial labour force in Japan is SME, 50% in Germany, 46% in USA are employed in smaller firms. Central Bank of Nigeria defined small scale enterprises as all businesses with a total assets' investment of less than one million, an annual turnover of less than one million and with a total number of employees of less than fifty (World Bank Mapping 2001). In addition, the International Finance Corporation (IFC) and Corporate Affairs Commission in 2001 further justified that

Nigeria's industrial sector is dominated by SMEs, estimated to be about 90% of the sector employing less than 50% of the people (HPACI 2002). Given the place occupied by the SMEs in Nigeria's industrial sector, it is expected that the success of the Nigerian economy would be partly dependent on the success of the SMEs. Nwoye (1991) pointed out clearly that SMEs are catalysts for Nigeria's economic growth and development. He believes that through so many SMEs, Nigeria has great potentials for success and growth, sales of large volume of goods etc. Even though, some of them have adequate capital, many of them fail due to poor financial management operations. Duranti and Thibodeau, (2001), Business performance refers to an ongoing process that involves managing the criteria for which an institution, agency or project can be held accountable. Typically, these criteria are represented as component parts of an internal system and cover the institution's ability to; control financial expenses, satisfy staff, deliver timely interventions and respond to target group reactions to interventions.

### **Empirical Framework**

According to Morries (2007) Small businesses have some inherent disadvantageous characteristics that will require that they be provided with public supports. Such characteristics, apart from limited managerial capabilities, include lack of economies of scale, lack of collective voice and influence on policy, frequent cases of market failures and/or biases against small businesses, weak financial capacity to undertake R&D or the costly support services such as Business Development Service (BDS), and huge knowledge gaps (most small business promoters don't know what they need to know but which they don't know). When these public supports are not available, chances of failure can be very strong. According to Oladejo (2008), the achievement of the firm's objectives is greatly influenced by the application of accounting records. Most businesses in Nigeria still are not aware of the importance and benefits of accounting records. It is found that accounting records are faced with some challenges which are inadequate infrastructural facilities, inability of most business firms to demand accounting systems adequate to them for their needs, lack of standardized professional body in accounting records and also local firms are been threatened by developed countries that are enjoying the full benefits of accounting records. He concluded that accounting records has contributed immensely to the unprecedented rate in the growth of small businesses in identifying the expenses, income, and profit and loss of a firm at the end of an accounting year.

In a study of 148 respondents in Nigeria (Enugu), Okoli (2011) links proper record keeping and profitability of small scale enterprises and assert that due to inadequate record keeping, the small scale operators could not assess their performances effectively. He argues that in order to enhance the profitability of small scale enterprises and their continuity, there is need for adequate record keeping which will help the proprietors to keep track of the performance of these enterprises. Mensah et al. (2007) states that a significant number of enterprises in their survey kept no records pertaining to operations, finance, audited accounts, tax returns, and so on. Until recently, all the micro and small enterprise could not receive credit from the banks and promotional institutions on grounds that the formal banking sector considered them a high risk area, and hence charged them high cost for borrowed funds from the banks. In assessing the financial statements of micro and small enterprises, Aryeetey et al. (1994) claims the existence of practical problems in deriving records and figures that make up the statements. One reason for that is because for almost all enterprises the owners keep all the records in memory and hence the lack of records of all kinds –sales, marketing, accounting, credit borrowing from lending institutions, staff costs, owners emoluments, etc. Owners of

SMEs do not keep proper records and thus, they are not able to provide data about their entities. Also Sege (2010) said small businesses fail because those who start them fail to carry out market research to find out if there is any genuine market for their products and/or services; Bother to get money sorted out before they start the business; Choose a feasibility business model; and Plan for growth or what happens if the business is a success; and plan an exit strategy.

**Hypotheses**

1.  $H_0$ : Small scale business do not keep proper accounting records of their financial transactions.
2.  $H_0$ : Accounting records keeping does not contributes in efficient performance of small scale business.

**Methodology**

The population for the study consists of twenty-eight (28) selected small scale businesses in Anambra state. The researchers used judgmental sampling technique to select as a representative to other small scale businesses in the area. Data collected for the study were analyzed by the researchers using frequency counts, mean score. The hypotheses were tested using Z-test. This was done to test significance different in mean between the two population mean when the sample size is large. The hypotheses were tested at 5% level of significance.

Using z-test

$$Z = \frac{\bar{x} - \mu}{\frac{\sigma}{\sqrt{n}}}$$

Where x = sample mean

- $\mu$  = Population mean
- $\sigma$  = Standard deviation
- n = Sample size

**Data Analysis**

**Summary of responses using five-point Likert's scale**

S/N	QUESTIONNAIRE	SA	A	U	SD	D	Total
1	Small scale business keeps the records in order to access the profitability of their transactions.	11 (55)	21 (84)	3 (9)	0 (0)	6 (6)	41 (154)
2 <sub>s</sub>	Some of SSB owners are has skill in accounting system.	9 (45)	17 (68)	2 (6)	4 (8)	9 (9)	41 (136)
3 <sub>s</sub> ou	Small scale business is engaged accountants to keep records of their financial transactions.	15 (75)	20 (80)	1 (3)	0 (0)	5 (5)	41 (163)
4 <sub>r</sub> c e	There is internal system to cover the business ability to control financial expenses.	13 (65)	22 (88)	0 (0)	2 (4)	4 (4)	41 (161)
5; f	A number of small scale businesskeeps records pertaining to operations, finance, etc.	18 (90)	23 (92)	0 (0)	0 (0)	0 (0)	41 (182)

6i e l	Accounting records have contributed immensely to the growth of small scale business.	14 (70)	20 (80)	3 (9)	0 (0)	4 (4)	41 (163)
7d s	There is a relationship between accounting records keeping and performance of small scale business.	10 (50)	28 (112)	0 (0)	0 (0)	3 (3)	41 (165)
8u r v	Some SME engaged professional accountants to determine the level of their profits.	12 (60)	27 (108)	0 (0)	2 (4)	0 (0)	41 (172)
9e y ,	Keeping adequate records is crucial for the successful performance of a business.	10 (50)	24 (96)	1 (3)	1 (2)	5 (5)	41 (156)
10 2 0 1	If proper records are kept, they will facilitate efficient, proper timely decision making and enhance performance in small business.	9 (45)	26 (104)	2 (6)	0 (0)	4 (4)	41 (159)

**Test of Hypotheses Hypothesis One**

HO: Small scale business do not keep proper accounting records of their financial transactions. HI: Small scale business kept proper accounting records of their financial transactions.

$$\begin{aligned} \text{Population mean } (\mu) &= \frac{3 \times 41 \times 5}{5} = 123 \\ \text{Sample mean } (X) &= \frac{\sum x}{n} = \frac{796}{5} = 159 \\ \text{SD } (\delta) &= \sqrt{\frac{(x-\mu)^2}{n}} = \sqrt{\frac{1103}{5}} = \sqrt{221} = 14.9 \\ \text{Z-test} &= \frac{x-\mu}{\frac{\delta}{\sqrt{n}}} = \frac{159-123}{\frac{14.9}{\sqrt{5}}} = \frac{24}{6.65} = 5.41 \end{aligned}$$

**Decision:**

Since the Z-calculated is higher than the Z- table (5.41 > 1.96), we reject the null hypothesis and accept alternative hypothesis which uphold that small scale business kept proper accounting records of their financial transactions.

**Hypothesis Two**

HO: Accounting records keeping does not contributes significantly to the performance of small scale business.

HI: Accounting records keeping contributes significantly to the performance of small scale business.

$$\begin{aligned} \text{Population mean } (\mu) &= \frac{3 \times 41 \times 5}{5} = 123 \\ \text{Sample mean } (X) &= \frac{\sum x}{n} = \frac{815}{5} = 163 \end{aligned}$$

$$SD(\delta) = \frac{\sqrt{n} \sqrt{5}}{n} = \frac{\sqrt{150}}{5} = \sqrt{30} = 5.48$$

$$Z\text{-test} = \frac{\bar{x} - \mu}{\frac{SD(\delta)}{\sqrt{n}}} = \frac{163 - 123}{\frac{5.48}{\sqrt{5}}} = \frac{40}{2.45} = \mathbf{16.33}$$

**Decision:**

Since the Z-calculated is higher than the Z-table (16.33 > 1.96), we reject the null hypothesis and accept alternative hypothesis which uphold that accounting records keeping contributes significantly to the performance of small scale business.

**Summary of Findings**

Based on the data analyzed and the literature reviewed, the followings findings were drawn;

1. Small scale business kept proper accounting records of their activities hence the owners employed public accountants to prepare their accounts.
2. Accounting records keeping contributes significantly to the performance of small scale business.
3. It revealed that if proper records are kept, they will facilitate efficient, proper timely decision making and enhance performance in small business.

**Conclusion and Recommendations**

This study has attempted to assess the impact of accounting small scale business. This study reviewed various forms including journal papers, articles and other relevant materials. Based on this, the study discovered that the need for an effective accounting system in promoting good performance in small scale enterprises in Nigeria has been studied in this research work. The problems militating against the operation of such system despite its apparent values were also examined. It was observed that although small scale enterprises may not be able to adopt elaborate systems of accounting, A number of small scale business kept no records pertaining to their financial operations, finance, etc while some employed professional accountants to keep proper accounting records of their business. The accounting records keeping contribute to the performance of small scale business hence small scale business not actually kept proper accounting records of their activities; they could be encouraged by customized adaptive systems.

Based on this, the researchers made the following recommendations;

The training of accountants by this institution and the various professional institutes should focus more on practical means of solving accounts reporting needs of small and medium scale enterprises; and that government should provide adequate financial assistance, this is because



if there is adequate financial support, more unemployed Nigerians will engage in small scale enterprises thereby gain their means of living easily than looking for unavailable while collar job.

## References

- Amoako, G. K. (2013). Accounting practices of SMEs: A case study of Kumasi Metropolis in Ghana. *International Journal of Business and Management*, 8(24).
- Anyigbo, C. I. (1999) *Cost and managerial accounting decision emphasis*. Enugu: Itugo2 Publication Limited.
- Aryeetey, E., Baah-Nuakoh, A., Duggleby, T., Hettige, H., & Steel, W. F. (1994). *Supply and demand for finance of small-scale enterprises in Ghana*. World Bank Discussion Paper No. 251. Washington, D.C.: The World Bank. <http://dx.doi.org/10.1596/0-8213-2964-2>
- Ademola, G. O., Samuel O. J. & Ifedolapo, O. (2012). The roles of record keeping in the survival and growth of small scale enterprises in Ijumu Local Government Area of Kogi State. *Global Journal of Management and Business Research*, 12(13).
- Abdulrasheed, A., Khadijat, A. & Oyebola, F. E. (2012). Accounting principles of small enterprises in ilorin metropolis of Kwara State, Nigeria. *Research Journal of Finance and Accounting*, 3(2).
- Adeyemi, S. L. & Badmus, A. L. (2001). An empirical study of small scale financing in Nigeria. *Journal of Unilorin Business School*, 1(1).
- Anheier, H. K. & Seibel, H. D. (1987). Small scale industries and economic development in Ghana: *Business and Strategies in Informal Sector Economics*, Verlag Breitenbech, Saarbruckh, Germany.
- Atijosan, Y. (1998) The ecology of small business: Implications for marketing management in management in Nigeria
- Aremu, M. A. & Adeyemi, S. L. (2011). Small and medium scale enterprises as a survival strategy for employment generation in Nigeria. *Journal of Sustainable Development*, 4(1).
- Blackwood, D. L. & Lynch, R. G. (1994). The measurement of inequality and poverty: A policy maker's guide to the literature. *World Development*, 22(14), 568 - 570.
- Bohman, H. & Boter, H. (1984). *Planning in small and medium-sized firms—The challenges and premises of the strategic planning*. Department of Business Administration and Economics, Umea University Sweden. Dasanayaka, S.W.S.B (2009) Small and medium scale enterprises in informal sector in Pakistan1 and Sri Lanka.

- Bititei, U. S., Suwignjo, P. & Came, A. S. (2001). Strategy management through quantitative modeling of performance measurement systems. *International Journal of production Economics* 69, 15-22.
- Barbara, R. (2010). Record management, change management, service systems. *Management Journal*, 20(1), 124-137.
- Boachie-Mensah, F. O., & Marfo-Yiadom, E. (2005). *Entrepreneurship and small business management*. Accra: Ghana Universities Press
- Crane, M. L. (1997). Record keeping. Essential to risk management NCIS. November, 1997.
- Covin, J. G. & Selvin, D. P. (2008). The Strategic Management of Small Firms in Hostile and Beginning Environments. *A strategic Management Journal*.
- Clute, R. C., & Gitman, G. B. (1980). A factor analytic study of the causes of small business failure. *Journal of Small Business Mnagement*, 30(2).
- Englam, A. and Bamidele, A. (1997). Measurement Issues in Poverty. In Poverty Alleviation in Nigeria, a selected paper for 1997 Annual Conference of the Nigeria Economic Society, NES, Pp. 141-156.
- Eric, E. O. & Gabriel, D. (2012), Challenges of book keeping on Small and Medium Scale Enterprises (SMEs) in Kwaebibirem District: The Case of Appex Global (Ghana) Limited. *International Journal of Business and Management Cases*, 1(2), 1-12
- Everaert, P., Sarens, G., & Rommel, J. (2006). *Outsourcing of accounting tasks in SMEs: An extended TCE Model*. Working Paper No. 2004/403. Universiteit Gent. Kuiperskaai, Belgium. Duranti, L. and Thibodeau, K. (2001). The Inter PARES International Research Project. *Information Management Journal*, 35(1), 44-50.
- Fitzgerald, L., Johnson, R., Brignall, S., Silverstro, R & Voss, C. (2006). *Performance measurement in service business*. London (CIMA)
- Holmes, S. & Nicholls, D. (1988). An analysis of the use of accounting information by Australian Small Business. *Journal of Small Business Management*, 26(2), 57-68
- Holmes, S. & Nicholls, D. (1989). Modeling the accounting information requirements of small businesses. *Accounting and Business Research*, 19(74), 143-150. Retrieved from <http://dx.doi.org/10.1080/00014788.1989.9728844>
- Ikechukwu, C. (1993). *Success key point book keeping and accounts*. Onitsha: Hybrid Publisher Limited.
- Ismail, N. A., & King, M. (2007). Factors influencing the alignment of accounting information in small and medium sized Malaysian firms. *Journal of Information System and Small Business*, 1(1-2), 1-20

- Morris, H. (2007). *Why businesses keep accounting record* 2nd edition. Houghton Mifflin Company.
- Jayabalan, J. & Dorasamy, M. (2009). Outsourcing of accounting functions amongst SME companies in Malaysia: An Exploratory Study. *Accountancy Business and the Public Interest*, 8(2), 96–114
- Keasy, K. & Short, H. (1990). The accounting burdens facing small firms: An empirical research note. *Journal of Accounting Business Research*, 20(80), 307–313. Retrieved from <http://dx.doi.org/10.1080/00014788.1990.9728889>
- Kinney, W. R. (2001). Accounting scholarship: What is uniquely ours? *The Accounting Review*, 76(2), 275–284. Retrieved from <http://dx.doi.org/10.2308/accr.2001.76.2.275>
- Lalin, H. & Sabir, R. I. (2010). *Research on usage and usefulness perception of financial accounting practices in less developing countries: A case of Cambodia*. Proceedings of the Proceedings of the 7<sup>th</sup> International Conference on Innovation & Management, 1881–1885.
- Hussein, M. E. I. M. (1983). *Accounting and Control Systems for Small Business*. Touché Ross Foundation
- Mensah, J. V., Tribe, M., & Weiss, J. (2007). The small-scale manufacturing sector in Ghana: A source of dynamism or of subsistence income? *Journal of International Development*, 19(2), 253–273. Retrieved from <http://dx.doi.org/10.1002/jid.1322>
- Nwoye, M. I. (1991); *Small business enterprises (How to start and succeed)*; Social Science Series Benin City Nigeria.
- Okafor, F. O. (1999). *Micro-credit: An instrument for economic growth and balanced development in Nigeria*” A paper presented at CIBN Annual Lecture, Lagos.
- Obadan, M. I. (1997). Analytical framework for poverty reduction issues of economic growth versus other strategies. in poverty Alleviation in Nigeria (Nigerian Economic Society (NES) Annual Conference Proceedings.
- Olatunji, T. E. (2000). *Practical approach to small business management Osogbo*”: MIDEAL Publications.
- Okoli, B. E. (2011). Evaluation of the accounting systems used by small scale enterprises in Nigeria: The Case of Enugu- South East Nigeria. *Asian Journal of Business Management*, 3(4), 235–240.
- Onaolapo A. A. & Adegbite, T. A. (2014). The analysis of the impact of accounting records keeping on the performance of the small scale enterprises. *International Journal of Academic Research in Business and Social Sciences*, 4(1).
- Oladejo, M. (2008). *Essentials of management and accounting* (2nd Ed.). Ikeja: Peace Concept.

- Prasad, S., Green, C. & Murinde, V. (2001). *Corporate financial structures in developing economies: Evidence from a comparative analysis of Thai and Malay corporations*. Working Paper Series, Paper No 35. Finance and Development Research Programme, University of Manchester, Manchester.
- Pacioli. L. (1494). *Summa de Arithmetica, Geometria, Proportioni et Proportionalita*. Venice: Paganini de' Paganini.
- Schmitz, H. (1995). Collective efficiency: Growth path for small – scale industry. *Journal of Development Studies*, 31(4), 529 – 566.
- Reed, R. (2010). *Good small business guide: How to start and grow your own business*. 2nd Edition. London: A & C Black publishers Ltd.
- Safiriyu, A. M. (2012) Impact of small and medium scale enterprises in the generation of employment in Lagos State in *Kuwait Chapter of Arabian Journal of Business and Management Review*, 1(11).
- Sege, B. (1993). *Concept and principles of accounting*. Lagos; Rankson Educational publisher.
- Schubert, R. (1994). Poverty in developing countries: Its definition, extent and implication. *Economic*, 49-56, 17-40.
- Tanwongsva, V., & Pinvanichkul, T. (2008). Accounting information requirements and reporting practices of Thai SMEs. *King Mongkut University Technology*, 59–74.
- Williams, J. R., Haka, S. F., Bettner, M. S., & Carcello, J. V. (2008). *Financial and managerial accounting*. New York, NY: Mc Graw-Hill Irwin.
- Zhou, L. (2010). The research on issues and countermeasures of accounting information of SMEs. *International Journal of Business Management*, 5(3), 223–225
- Zoubi, T. A. & Al-Khazali, O. (2011). Adopting US-GAAP or IASB Accounting Standards by the Arab countries. *International Business & Economics Research Journal*, 3(10).



## Women Empowerment: Panacea for Poverty Reduction and Economic Development in Nigeria

<sup>1</sup>Omolaiye Happy Ojo & <sup>2</sup>Akindele Oluwafemi

<sup>1&2</sup>Department of General Studies,  
The Federal Polytechnic Ile-Oluji Ondo State, Nigeria

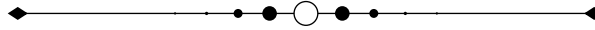

### **Abstract**

*Many women entrepreneurs in developing countries most especially Nigeria are facing disproportionate obstacles due to lack of mobility, capacity and technical skills, with some experiencing several discrimination, hardship and exclusion. This paper examines women empowerment as a panacea for economic development and poverty reduction in Nigeria. The study tests the hypothesis that women empowerment has effect on poverty reduction. Data used for this study were sourced from both secondary and primary sources of data. The data were analyzed using frequency tables, percentages, mean and z-test. The study was conducted using some selected women entrepreneurs registered with National Association of Small-Scale Industries (NASSI) in Edo State, Nigeria. The study found out that women need education, skills, and access to assets/credit, social protection in order to fully develop their productive assets and tackle poverty. The researchers recommended that for women, their families and society to reap the benefits of economic development and poverty reduction; investments in and empowerment of women both economic and socially are inevitable and be given ultimate priority.*

**Keywords:** Economic development, Empowerment, Poverty reduction, Women

---

## **Introduction**

Women in Nigeria are active participants in nation building. From the home front all the way to governance, women have been seen to be outstanding in all human endeavours. The rural woman in Nigeria specifically, engages in all manner of hard labour to eke out a living for the entire household. Many households in Nigeria are being fed, clothed and catered for by the sweat and blood of hard-working women. Despite abuses by the men-folk and the abject poverty where women are most hit, they still stick to any laid down moral code, while attending to societal demands and courageously raising and implementing family budgets, no matter the financial implication involved. International organizations like USAID, DFID, IMF, World Bank, government and others spirited individuals and private organizations have made concerted efforts in helping women economically, but yet level of poverty has persisted. Women potential labour force is still very high in Nigeria and most of the poor are women. Women consist more than 60% of the African population which has given concern to the economy of the world. Akomolafe (2006) defines women empowerment as the development of mental and physical capacity, power and skills in women for them to operate meaningfully in their social milieu, thereby experiencing a more favourable level of social recognition and subsequently enhance their economic status.

Danjuma, Muhammad, & Alkali (2013) maintain that the aim of women economic empowerment is to enhance the socio-economic status of women through creating an economic culture that will address the technical know-how in the pursuit of women's multi-faceted roles, retooling them with various economic ventures as well as enhancing the emancipation of women from poverty. While this is because women are generally regarded as being "poor" and they constitute majority of the population of Nigeria. Promoting women's economic empowerment is seen as the driving forces behind reducing poverty and aiding economic growth.

## **Statement of the Problem**

Women most often face discrimination and persistent gender inequalities, while some women are experiencing multiple discrimination and exclusion because of factors such as ethnicity or caste. Many women entrepreneurs in developing countries face disproportionate obstacles in accessing and competing in markets. These include women's relative lack of mobility, capacity, assets and technical skills in comparable to men.

Unequal opportunities between women and men continue to hamper women's ability to lift themselves from poverty and gain more options to improve their living standards. The discriminatory practices and stereotypical attitudes prevent women in some parts of Nigeria from accessing financial support to build their businesses. In some countries women are unable to obtain business loans without their husbands or father's co-signature and support. Women perform the bulk of unpaid care work across all economies and cultures. In many societies, existing norms dictate that girls and women have the main responsibility for the care of children, the elderly and the sick, as well as for running the household, including the provision of water and energy supplies. These hinder women chances of being properly educated or being able to translate returns on their own productive work into increased and more secure incomes, better working conditions and increase standard of living.



### **Objectives of Study**

1. To ascertain the effects of poverty on economic empowerment of women
2. To examine the effect of discrimination against women on women economic empowerment
3. To determine the relationship between women empowerment and unemployment

### **Research Questions**

1. What are the effects of poverty on economic empowerment of women?
2. Is discrimination against women an obstacle to women empowerment?
3. Is any positive relationship exists between women empowerment and unemployment?

### **Hypotheses**

- H<sub>1</sub>: A significant positive relationship exists between women empowerment and poverty
- H<sub>2</sub>: There is a positive relationship between women empowerment and discrimination against women
- H<sub>3</sub>: A significant positive relationship exists between women empowerment and unemployment

### **Literature Review**

#### **Women's Economic Empowerment**

World Bank (2001) defines empowerment as the expansion of freedom of choice and actions and increasing one's authority and control over the resources and decisions that affects one's life. Similarly, Kabeer (2001) sees women's empowerment as a process through which women gain the ability to take ownership and control of their lives. Although the process of empowerment depends on women themselves involving consciousness raising, participation, and organizing themselves, it can also be facilitated through education, capacity building, training and other measures. Empowerment refers to the process of change that gives individuals greater freedom of decision, choice and action. A process of economic empowerment for women is dependent upon available resources and whether women have the skills to use them; access to economic opportunities; and control over economic benefits that can be used to achieve positive change. A woman is said to be economically empowered when she has:

- (i) The ability to succeed and advance economically; and
  - (ii) The power to make decisions and act on economic decisions without interference.
- Schmitz (2009) defines women's economic empowerment as the process which increases women's real power over economic decisions that influence their lives and priorities in society

Economic empowerment is the capacity of women and men to participate in, contribute to and benefit from growth processes in ways which recognize the value of their contributions, respect their dignity and make it possible to negotiate a fairer distribution of the benefits of growth (Eyben, Kabeer, and Cornwall 2008). Economic empowerment increases women's access to economic resources and opportunities including jobs, financial services, property and other productive assets, skills development and market information. Women's economic and political empowerment was adopted as one of the strategies for advancing the agenda of gender equality at the IV UN Conference on Women in 1995.

### **Women Empowerment and Economic Development**

Women's economic empowerment is recognized as one means for reducing poverty and economic growth. Women play a significant role in Nigerian economy, and are highly visible in the micro and small enterprises sub-sector. The majority of them are engaged in small income generating self-employment in agriculture and non-agricultural activities with low prospect for growth (Dejene, 2014). Vandana and Robert (2014) report that as a result of women's wide-ranging responsibilities; productive, domestic and community duties, they are generally involved in a broader range of tasks than men and will therefore require a wider range of technical knowhow on which to draw for their livelihood pursuits. Clinton (2009) the former president of United States of America addressing the annual meeting of the Clinton Global initiative opines that "women perform 66 percent of the world's work, and produce 50 percent of the food, yet earn only 10 percent of the income and own 1 percent of the property" The president maintains that whether the case is improving education in the developing world, or fighting global climate change, or addressing nearly any other challenge we face, that empowering women would be critical part of the equation.

Studies show that women are affected by poverty, susceptible to diseases, prone to discrimination, marginalization and environmental degradation which are all detrimental to women economic empowerment and poverty reduction (Danjuma, Muhammad, & Alkali, 2013). But when they are empowered these will basically be reduced or completely alienated. The economic empowerment of women is a prerequisite for sustainable development, pro-poor growth and the achievement of all the millennium development Goals (MDGs). Gender equality and empowered women are catalysts for multiplying development efforts. Investments in gender equality yield the highest returns of all development investments (OECD, 2010). A higher proportion of earnings of women are invested in their families and communities than men. A study conducted by United Nations (2010) stress that investing in women and girls has a multiplier effect on productivity, efficiency and sustained economic growth. The economic empowerment of women is a human rights and social justice issue, but it also reduces poverty, and strengthens economic growth and development. Women's economic participation and empowerment are fundamental to strengthening women's rights and enabling women to have control over their lives and exert influence in society (Swedish ministry for foreign affairs, 2010).

Zoellick, (2010) commenting on the Brazil's economy asserts that the likelihood of a child's survival increased by 20% when the mother controlled household income. Increasing the role of women in the economy is part of the solution to the financial and economic crises that are critical for economic resilience and growth. Higher female financial earnings and bargaining power translate into greater investment in children's education, health and nutrition, which leads to economic growth in the long term (DFID, 2010). Economic empowerment also contributes to the reduction of gender-based violence, increases women's family-planning possibilities and slows the spread of HIV/Aids. Women's improved economic situation provides opportunities to escape exploitative relationships at home by breaking the economic dependence on a partner that is often at the root of domestic violence. Empowerment entails an expansion of women's choices, including those in the domain of sexual and reproductive health. An increase in women's decision-making power and control over their reproductive health can facilitate in reducing the number of children in each household. Economic empowerment of women and in the promotion of gender equality has broad multiplier effects for human development and reduction in women violence and maltreatment at home and

work. Economic empowerment puts women in a stronger position and gives them the power to participate, together with men, in the shaping of society, to influence development at all levels of society, and to make decisions that promote their families and their own wellbeing. In the united efforts to achieve the Millennium Development Goals; which recognizes that gender equality, the empowerment of women with women's full enjoyment of all human rights and the eradication of poverty are essential to economic and social development.

### **Process of Women's Economic Empowerment**

Women's economic empowerment is a prerequisite for sustainable economic development and pro-poor growth. To achieve women's economic empowerment anticipation requires sound government policies, and long-term commitment. Gender-specific perspectives must be incorporated at the initial design stage of policy and programming. Women must have equal equitable access to assets and services; infrastructure programmes should be designed to the benefit of the poor, both men and women, and employment opportunities must be improved while increasing recognition of women's vast unpaid work (OECD DAC Network on Gender Equality, 2012). Women's Economic Empowerment can be achieved through equal access to and control over critical economic resources and opportunities, and the elimination of structural gender inequalities in the labour market including a better haring of unpaid care work. Interventions aimed at promoting women's economic empowerment will help in achieving full recognition and realization of women's economic rights, and ultimately sustainable development.

Women's economic empowerment can be achieved given the following:

- (i) The resources are available and women have the skills to utilize them
- (ii) They have access to economic opportunities and control over the economic benefits of those opportunities; and
- (iii) They can use those benefits to make strategic choices leading to positive changes in their lives and improve their standard of living and that of their family

### **Obstacles to Women's Economic Empowerment**

- (i) Lack of fund: Many of these women rely on personal savings or on contributions from relatives and friends to fund their enterprises, and without property ownership they lack collateral to access credit from formal financial institutions.
- (ii) Scale of operation: Most women in developing countries especially Nigeria has small enterprises operating mainly in the informal sector of economy. They face multiple challenges that diminish their opportunities and dampen their potential as businesswomen and entrepreneurs.
- (iii) Education and training: They have limited access to education and training, have less or no freedom to choose their business, and are faced with discriminatory attitudes in property, marital and inheritance laws.
- (iv) Structural and cultural factors: These make it more difficult for women to access vocational training programmes due to their care giving responsibilities and societal expectations about which jobs are suitable for them.
- (v) Female illiteracy: women's lack of access to information, illiteracy, and gender discriminatory norms that prevent women from using and/or owning land are examples of obstacles that limit their access to and control of economic resources.
- (vi) Exploitative and discriminatory working conditions: gender segregation in the labour

market, restricted mobility, women's double work burden and diminished health caused by gender-based violence, for instance are examples of factors that limit women's ability to access and/or enjoy the returns on their work.

- (vii) Lack of infrastructure: Women who live in rural communities with low infrastructure, (transport, water and sanitation, communication and electricity) are worse affected. A World Bank study (Malmberg, 1996) reports that 87 percent of trips in rural Africa take place on foot.
- (viii) Greater vulnerability to sexual exploitation and abuse at the community level, if not the household level (Mayoux, 2009).
- (ix) Unpaid work: both in the productive and domestic spheres is one of the most important challenges to women's economic empowerment for economic sustainability. As indicated earlier, women's ability to be more actively engaged themselves in their economic activities is partly affected by the heavy labour burden and time poverty associated with their family responsibilities.

### Methodology

The paper examines women empowerment as a panacea for economic development and poverty reduction in Nigeria. The study was conducted using some selected women entrepreneurs registered with National Association of Small Scale Industries (NASSI) in Enugu State, Nigeria. Sample size of 267 from a population of 809 registered women entrepreneurs was derived using Williams 1986. 211 copies of questionnaire representing 79% of the questionnaire were accepted for analysis. The study adopted a survey approach. Data used for this study were sourced from both secondary and primary sources of data. The data were analyzed using frequency tables, percentages, mean and Pearson correlation. Five-point Likert measurement scale, with answers ranging from 1 to 5, of strongly agrees to strongly disagree was adopted. SPSS Software 2010 was used to analyze the data collected.

**Data Analysis Table 1. Personal Data of the Female Respondents**

1.	Marital Status	Frequency	Percentage
	Married	112	53
	Single	25	12
	Divorced	12	6
	widowed	58	27
	Separated	4	2
	<b>Total</b>	<b>211</b>	<b>100</b>
2.	Ages	Frequency	Percentage
	Below 25 years	31	15
	26 – 35 years	25	12
	36 – 45 years	63	29
	46 – 55 years	55	26
	56 and above	37	18
	<b>Total</b>	<b>211</b>	<b>100</b>

3.	Highest Educational Qualification	Frequency	Percentage
	F.S.L.	35	17
	WACS/GCE/ NECO Trade Certificate/ Diploma/ O.N.D/H.N.D	105	50
	First Degree	45	21
	M.Sc/Ph.D	26	12
		0	0
	<b>Total</b>	<b>211</b>	<b>100%</b>

**Source: Field data, 2023**

From the personal profile in table 1 on the marital status of the respondents, out of 211 respondents, 112 respondents making about 53% were married, 58 respondents making about 27% are widowed, 25(12%) respondents are single; 12(6%) respondents are divorced; while 4(2%) are separated. On the age brackets of the respondents, 63 respondents making a total of 29% out of the 211 respondents indicate that their ages falls between 36 – 45 years, 55(26%) respondents are between the ages of 46 – 55 years, 37 (18%) are between the ages of 56 and above, 25(12%) respondents are between the ages of 26 and 36 years.; while 21(15%) of the respondents are below 25 years. Also, table 1 shows the highest educational qualifications of the respondents. Out of 211 respondents, 105 respondents making about 50% have WASC/GCE/NECO, 45(21%) have Trade Certificate/Diploma/O.N.D, 35(17%) have F.S.L., 26 respondents making about 12% have H.N.D/B.Sc; while none of the respondents have MBA/M.Sc/Ph.D.

**Table 2. Classes of Business**

Class	Frequency	Percentage
Agro base/food processing	63	30
Service	123	58
Manufacturing	25	12
Total	211	100

**Sources: Field survey, 2023**

From table 2, 123 respondents making about 58% indicated that they engage in agro/food processing business, 63 respondents making about 30% said services; while 25 respondents giving about 12% indicates manufacturing.

**Table 3: Variables from the Questions**

	N	Minimum	Maximum	Mean	Standard Deviation
Women empowerment	211	1.24	6.79	3.4	.7632
Poverty	211	1.60	4.96	3.4	.6328
Discrimination	211	.99	4.8	3.2	.7502
Unemployment	211	1.46	7.8	3.6	.7079

The 3 above shows the mean and standard deviation scores of dependent variables well as the independent variables that were adopted for analysis. To the research questions, the respondents were asked to rate each of the three dimensions (variables) on a five-point Likert scale ranging from strongly disagree (1) to strongly agree (5).

**Table 4: Correlation Analysis of Relationship between Women Empowerment and Measuring Variables of Poverty, Discrimination and Unemployment**

	Poverty	Discrimination	Unemployment	Women Empowerment
Poverty Pearson Correlation	1	.721**	.642**	.732
Sig. (2-tailed)		.000	.000	.000
Discrimination Pearson Correlation	.721**	1	.642**	.756**
Sig. (2-tailed)		.000	.000	.000
Unemployment Pearson Correlation	.642**	.732**	1	.835**
Sig. (2-tailed)	.000	.000		.000
Women Empowerment Pearson Correlation	.732**	.756**	.835**	1
Sig. (2-tailed)				

\*\* Correlation is significant at the 0.05 level (2-tailed).

Table 4 ascertains the correlation analysis of women empowerment with the measuring variables: poverty, discrimination and unemployment. The value for poverty is 0.721 which shows a high significance of relations; while value for discrimination is 0.642 and unemployment is 0.732; while the 2-tailed significance level (sig) is .000 with a total of 211.



The correlation between women empowerment and the variables is statistically very significant given that the 2-tailed significance is less than .05. Thus, the null hypotheses relating to women empowerment can be rejected that no positive relationship exists between women empowerment and the variables.

**Table 5: Model Summary**

Model	R	R Square	Adjusted R Square	Std. Error of the Estimate
1	.641a	.412	.400	.58765

a. Predictors: (Constant), poverty, discrimination, unemployment

The model summary in table 5 shows that the multiple correlation coefficient using the predictors poverty, discrimination, and unemployment predictors simultaneously is  $R = 0.641$  while R Square is .412, indicating that the variance in women empowerment can be readily predicted from the combination of various factors poverty, discrimination and unemployment.

**Table 6: ANOVA**

Model	Sum of Squares	Df	Mean Square	F	Sig.
Regression	49.865	3	9.597	28.563	.000b
Residual	68.064	20	.347		
Total	117.929	21			
		0			

- a. Dependent Variable: women empowerment
- b. Predictors: (Constant), poverty, discrimination, unemployment.

From table 6 above,  $F = 28.563$  showing that the independent factors (predictors), namely poverty, discrimination and unemployment, combined to predict the women empowerment behaviour towards economic development. The value of the significance lies between 0% and 5%, indicating that the model is a good fit. Since the relationship between independent and dependent variables is very significant, we assume that the model is a good fit.

**Reliability Analysis**

To determine the reliability of the questionnaire; firstly, the reliability analysis was obtained by logging in about 30 responses on the initial batch. At that time the Cronbach Alpha was 0.73.

The present reliability analysis obtained is shown below.

**Table 7: Reliability Statistics**

Cronbach's Alpha	No. of Items
.764	6

The value for 211 respondents is .764. Since the value is above 70% or 0.7, it indicates that the questionnaire was reliable in collecting the information intended.

### **Findings**

The result indicates that women empowerment had a high relationship with poverty, discrimination, unemployment and economic development. The correlation analysis of the results using Pearson's correlation coefficient  $R = 0.641$  shows that there is high relationship. The result revealed that poverty can have negative effect on women empowerment. It was shown that  $M = 3.440$ ;  $SD = .6328$ ;  $p = .05$ . The study also revealed that discrimination against women has negative effect on women empowerment. This was shown in the true value of  $M = 3.242$ ,  $SD = 0.7502$ ;  $p = .05$ . Also, women empowerment is affected by unemployment. The result revealed that there is a negative relationship between women empowerment and unemployment. The variable was found to be moderately correlated,  $r = 0.641$ ;  $p < 0.05$ ,  $M = 3.603$ ,  $SD = 0.7079$ .

### **Conclusion/ Recommendations**

Women need education, skills, access to assets/credit, social protection in order to fully develop their productive assets and tackle poverty. In reality, women face many challenges in their entrepreneurial development and overcoming many of the obstacles requires reduction in gender discriminatory norms and practices. The researcher recommends that for women, their families and society to reap the benefits of economic development and poverty reduction; investments in and empowerment of women both economic and socially is inevitable.

### **References**

- Adegoroye, A. A. (2008). The roles of selected NGOs in economic empowerment of rural women in Ibadan Land. *Journal of Gender and Behavior*, 6(2), 25-37.
- Akomolafe, C. O. (2006). Open and distance learning as a mechanism for women empowerment in Nigeria. *Educational Foundations and Management*
- Danjuma, M. & Alkali, O. (2013). Factors militating against women economic empowerment and poverty reduction in African countries *IOSR Journal of Business and Management*, 13(6), 47-51.
- Dejene, Y. (2014). Promoting women's economic empowerment in Africa. Retrieved from <http://www.afdb.org/fileadmin/uploads/afdb/Documents/Knowledge/25040341-FR-DRAFT-DEJENE.9-15-07DOC.PDF>
- Department for international development (DFID) (2010). Agenda 2010 the turning point on poverty: Background paper on gender. London: DFID.
- Eyben, R., R. Kabeer, N. & Cornwall, A. (2008). Conceptualising empowerment and the implications for pro poor growth: A paper for the DAC Poverty Network. Brighton, Institute of Development Studies.

- Kabeer, N. (2001). Reflections on the measurement of women's empowerment. Discussing women's empowerment: Theory and practice. Sida. Stockholm, Swedish International Development and Cooperation Agency.
- Malmberg, C. (1996). Case study on the role of women in rural transport: Access of women to domestic facilities. In Sub-Sahara Africa Transport Policy Program – WB and ECA Working Paper 11.
- Mayoux, L. (2009). Questioning virtuous spirals: Micro-finance and women's empowerment in Africa." *Journal of International Development*, 11(6), 957-984.
- OECD DAC Network on Gender Equality (2015). *Women's economic empowerment*. retrieved from <https://www.oecd.org/dac/povertyreduction/50157530.pdf>
- Schmitz, C. (2009). Working Paper December on Sida Gender Equality Team Indevelop-IPM, Sida.
- United Nations (2010). *Keeping the promise: United to achieve the millennium development goals*. New York: United Nations
- United Nations Development Program (1995). *Human development report*. New York
- Vandana, D. & Robert, B. P. (2014). *The companion to development studies*. New York. Routledge, Talor and Fransis Group.
- Williams, F. (1986). *Reasoning with statistics – How to read quantitative research*. Florida: Halt, Rinchart and Winton Inc.
- World Bank (2001). Engendering development through gender equality in rights, resources, and voice.
- Zoellick, R. (2010). Extracted from World Bank President Zoellick's speech at the MDG3 conference, copenhagen, 25 march.



## The Impact of Radio Lectures Method on Teaching and Learning of NCE II Biology Students of Federal College of Education, Zaria

<sup>1</sup>Dalhatu Hadiza Umar <sup>2</sup>Abubakar Salisu & <sup>3</sup>Ibrahim Muinat Mahmoud  
<sup>1,2&3</sup>Department of Biology  
Federal College of Education, Zaria

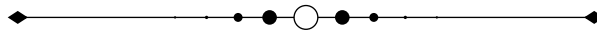

### Abstract

*This entitled "Radio-Lecture Use in the Teaching and Learning of NCE II Biology Students in Federal College of Education, Zaria. The research work find out the following objectives which include find out if there is mean difference between student academic achievement in Biology before and after radio lecture methods among NCE II students, assess the level of awareness of radio lecture in Biology educational programmes among NCE II students in Federal College of Education, Zaria. The research work concluded that difference between student academic achievement in Biology before and after radio lecture among NCE II students. It was also concluded that there is no awareness of radio lecture method in Biology educational programmes among NCE II students in Federal College of Education, Zaria. Finally, the research work recommended that Ministry of education should implement teaching and learning with Information and Communication Technology in tertiary level curriculum and Schools administration shouldn't be depending on government for the provision of Information Communication Technology (ICT) facilities to school.*

---

### Introduction

Teaching is intimate contact between a more mature personality and a less mature one which designed to further the education of the latter". Morrison (2010), Dewey (2013) expressed this concept of teaching by an equation. "Teaching is learning as selling is to be buying". In the words of John Brubacher (2011), "Teaching is arrangement and manipulation of a situation in which there are gaps or obstructions which an individual will seek to overcome and from which he will learn in the course of doing so". B.O. Smith defined teaching as "Teaching is a

system of actions intended to induce learning". According to Gage (2017), "Teaching is a form interpersonal influence aimed at changing the behaviour potential another person". Smith in 1963 further extended the definition of teaching. Teaching is a system of actions involving an agent, an end in view and a situation including two sets of factors those over which the agent has no control (class size, characteristics of pupils, physical facilities, etc.) and those which he can modify (such as techniques and strategies of teaching).

Learning can be defined as the activity or process of gaining knowledge or skill by studying, practicing, being taught, or experiencing something (Merriam-Webster dictionary). Learning is about what students do, not about what we as, teachers do. In common parlance the word 'learning' carries at least two meanings. There is a general one of some kind of change, often in knowledge but also in behavior. However, learning cannot be defined merely in terms of changes in behavior. But there is also a more intense sense of the verb 'to learn' meaning to memorize, to learn by heart (Roger. 2013). To say that 'learning is change' is too simple. Not all change is learning. What we usually mean by 'learning' are those more or less permanent changes and reinforcements brought about voluntarily in one's patterns of acting, thinking and/or feeling (Roger, 2013).

Teaching and learning is a process that includes many variables. These variables interact as learners work toward their goals and incorporate new knowledge, behaviours, and skills that add to their range of learning experiences.

As part of the reforms the curriculum places a lot of emphasis on Information and Communication Technology (ICT) as a tool for teaching Biology. That is why Government introduced radio-lecture in its effort to systematically embrace ICT in teaching Biology across the levels of NCE. Not only that emergence of corona virus (Covid-19) pandemic and the rampant insecurity in Kaduna State which led to closures of educational institutions has forced many schools to adapt other means of instructions among which is radio-lectures. Radio interventions used for school education are used to teach core subjects such as English language, Biology and civic education. This has led to the development of FM radio which is expected to assist with all levels of NCE academic achievement. Several research studies have also shown that radio learning programmes can reach a wide area as well as hard-to-reach places and

### **Statement of the Problem**

Similarly, radio stations in Federal College of Education Zaria, Nigeria have also produced series of educational programmes packaged and broadcast for the consumption of students in the college from various departments. In this regard, this research intends to find out the use of radio-lecture in the teaching of basic general Biology, its implications to students' academic achievement in Federal College of Education Zaria, Kaduna State. More so, no study, to the best of our knowledge has established the existing radio educational programmes into general studies education students in Federal College of Education Zaria, Kaduna state, Nigeria.

### **Objectives of the Study**

The purpose of this study is to assess the impact of radio lecture use on academic achievement of Federal College of Education Zaria students in Ibadan city, Nigeria. Specifically, the study seeks to:

- i. To determine the exposure of NCE II Biology to the radio lectures
- ii. Examine the influence of radio lecture method on the academic performance of NCE II Biology Students of Federal College of Education, Zaria.

### **Research Questions**

1. What is the level of exposure of NCE II biology students of Federal College of Education, Zaria to radio lecture method?
2. What is the influence of; radio lecture method on academic performance of NCE II Biology of Federal College of Education, Zaria?
3. What is the attitude of lectures towards radio lecture method on academic performance of NCE II Biology students of Federal College of Education, Zaria?

### **Hypothesis**

1. There is no significance difference between the level of exposure of NCE II Biology students of Federal College of Education, Zaria to radio lecture method is less.
2. There is no significance difference between Radio lecture method has no significance influence on the academic performance of NCE II Biology students of Federal College of Education, Zaria.

### **Research Methodology**

#### **Research Design**

The study adopted a descriptive survey designed the design aims at describing the state of affairs as they exist. Therefore, the design for this study will be appropriate because it will enable the researcher to obtain pertinent and precise information from the respondents in order to establish radio lectures in teaching and learning during covid-19.

#### **Population of the Study**

The population of the study involves all students within Federal College of Education Zaria with the total number of nine hundred and fifty-five (955). They are to be given questionnaires and obtain relevant information.

#### **Sample Size and Sampling Techniques**

The sample consists of students, and students of college. Random sampling techniques will be used to sample (70) NCE II Biology students from Federal College of Education, Zaria. Total number of (70) students will therefore be sampled for the study. Stratified sampling techniques will be used to sample. One hundred percentages (100%) will be used in the sample.

#### **Instrument for Data Collection**

The instrument to be used for data collection for this study is four rating scale structured questionnaire. The questionnaire will be divided into two (2) Sections 'A' and 'B' Section A will deal with the data of the respondents such as age, gender, status, level of education etc. while Section 'B' deals with four (4) research questions raised in chapter one.

#### **Data Collection Procedure**

A letter of introduction will be written to each school among the selected Federal College of Education, Zaria, Kaduna State to seek for approval and permission to conduct the study using their students. The researchers will distribute the questionnaire personally to students in



the schools and collect the responses on the same day.

**Method of Data Analysis**

The data collected for the study will be analyze using simple percentage alongside narrative discussion using frequency table easy interpretation of the data. The analysis will be presented in tabular of the data. The analysis will present in tabular form showing relationship between the gathered information and data. All strongly agreed and agreed would be treated as agreed all strongly, disagreed and disagreed would be treated as disagreed in the analyses of data collected.

**Presentation of Data and Analysis**

**Mean difference between student academic achievement in Biology before and after radio**

S/N	Items	Frequency				Percentage				Total
		SA	A	S	D	SA	A	SD	D	
1.	Students achievement was averagely excellent before the introduction of radio lectures	19	21	16	14	27.2	30	22.8	20	100
2.	Students' academic performance is highly recommended in terms of quality after the introduction of radio lectures	25	27	10	8	35.7	38.6	14.3	11.4	100
3.	Radio lectures is better than any methods of teaching	20	30	7	13	28.6	42.8	10	18.6	100
4.	Students and lecturers enjoy radio lectures far better than any method of teaching during learning	19	21	17	10	27.2	30	24.3	14.3	100

**Source:** Researcher's Survey. 2022

The survey result in table above shows that, 19 (27.2%) and 21 (30%) of the respondents strongly agreed and also agreed that Students achievement was averagely excellent before the introduction of radio lectures. In addition to this reasonable percentages of the respondents 16 (22.8%) and 16 (22.8%) disagreed with that view which also indicates a negative response to the question.

Table above revealed that 25(14.3%) and 27(38.6%) of the respondents strongly agreed and also agreed that Students' academic performance is highly recommended in terms of quality after the introduction of radio lectures, while majority of the respondents 10 (14.3%) and 8(11.4%) strongly agreed as well as disagreed with that view. The result in table. 4.2.3 above shows that 20 (28.6%) and 30(42.8%) of the respondents strongly agreed and Radio lectures is better than any methods of teaching, majority 7(10%) and 13 (18.6%) also agreed with that view.

The result in table above revealed that 25(35.7%) and 25(35.7) of the respondents favoured the opinion that Radio lectures is better than any methods of teaching 13(18.6%) and 7(10%) of them viewed it in same direction through their acceptance with agreed opinion that Radio lectures is better than any methods of teaching. Table above revealed that 19(27.2%) and 21(30%) of the respondents strongly agreed and also agreed that Students and lecturers enjoy radio lectures far better than any method of teaching during learning, while majority of the respondents 16(22.8%) and 14(20%) strongly agreed as well as disagreed with that view.

### Assess the level of awareness of radio Lecture in teaching and learning of Biology among NCE II Students.

S/N	Items	Frequency				Percentage				Total
		SA	A	S	D	SA	A	SD	D	
1.	NCE II students learned faster using radio-lectures	8	4	5	3	40	20	25	15	100
2.	NCE II lecturers lecture easily learned with the use of radio-lectures	6	5	7	2	30	25	35	10	100
3.	Radio lectures discourage learning and teaching among NCE II students	7	6	3	4	35	30	15	20	100
4.	Radio lectures encourage learning and teaching among NCE II students	9	5	3	3	45	24	15	15	100

**Source:** Researcher's Survey, 2022

The result in table above, indicates that most of the respondents 8(40%) strongly agreed that NCE II students learned faster using radio-lectures, 4(20%) of them also agreed with that view. 5(25%) of the respondents strongly disagree that NCE II students learned faster using radio-lectures, while a lower response 3(15%) of the respondents disagreed with the opinion.

The survey results in table above shows that most of the respondents 6(30%) of the respondents strongly disagreed that NCE II lecturers lecture easily learned with the use of radio-lectures 5(25%) of the respondents agree that NCE II lecturers lecture easily learned with the use of radio-lectures. In addition to this a moderate proportion 7(35%) and 2(10) strongly disagree and also disagree that NCE II lecturers lecture easily learned with the use of radio-lectures.

The assessment result in table revealed that 7(35%) of the respondents strongly agreed that radio lectures discourage learning and teaching among NCE II students, 6(30%) of the respondents also agree that 3(15%) of the total respondents strongly disagreed that of the respondents, in addition to this 4(20%) of the respondents also disagreed with the opinion that radio »lectures discourage learning and teaching among NCE II students.

The result in table above indicates that 9(45%) of the respondents strongly agreed that radio lectures encourage learning and teaching among NCE II students. 5(25%) of the respondents come up with different opinion that radio lectures encourage learning and teaching among NCE II students 3(15%) and 3(15%) of the respondents strongly agree and disagree that radio lectures encourage learning and teaching among NCE II students.

#### Discussion of Major Findings

The survey result in table above shows that, 19 (27.2%) and 21 (30%) of the respondents strongly agreed and also agreed that Students achievement was averagely excellent before the introduction of radio lectures. In addition to this reasonable percentages of the respondents 16 (22,8%) and 16 (22,8%) disagreed with that view which also indicates a negative response to the question.

Table above revealed that 25(14.3%) and 27(38.6%) of the respondents strongly agreed and also agreed that Students' academic performance is highly recommended in terms of quality after the introduction of radio lectures, while majority of the respondents 10 (14.3%) and 8(11.4%) strongly agreed as well as disagreed with that view. The result in table above shows that 20 (28.6%) and 30(42.8%) of the respondents strongly agreed and radio lectures is better

than any methods of teaching, majority 7(10%) and 13 (18.6%) also agreed with that view.

The result in table revealed that 25(35.7%) and 25(35.7) of the respondents favoured the opinion that Radio lectures is better than any methods of teaching 13(18.6%) and 7(10%) of them viewed it in same direction through their acceptance with agreed opinion that Radio lectures is better than any methods of teaching. Table above revealed that 19(27.2%) and 21(30%) of the respondents strongly agreed and also agreed that Students and lecturers enjoy radio lectures far better than any method of teaching during learning, while majority of the respondents 16(22,8%) and 14(20%) strongly agreed as well as disagreed with that view. The result in table above, indicates that most of the respondents 8(40%) strongly agreed that NCE II students learned faster using radio-lectures. 4(20%) of them also agreed with that view, 5(25%) of the respondents strongly disagree that NCE II students learned faster using radio-lectures, while a lower response 3(15%) of the respondents disagreed with the opinion.

The survey results in table above shows that most of the respondents 6(30%) of the respondents strongly disagreed that NCE II lecturers lecture easily learned with the use of radio-lectures 5(25%) of the respondents agree that NCE II lecturers lecture easily learned with the use of radio-lectures. In addition to this a moderate proportion 7(35%) and 2(10) strongly disagree and also disagree that NCE II lecturers lecture easily learned with the use of radio-lectures.

The assessment result in table revealed that 7(35%) of the respondents strongly agreed that radio lectures discourage learning and teaching among NCE II students, 6(30%) of the respondents also agree that 3(15%) of the total respondents strongly disagreed that of the respondents, in addition to this (20%) of the respondents also disagreed with the opinion that radio lectures discourage learning and teaching among NCE II students. The result in table above indicates that 9(45%) of the respondents strongly agreed that radio lectures encourage learning and teaching among NCE II students. 5(25%) of the respondents come up with different opinion that radio lectures encourage learning and teaching among NCE II students 3(15%) and 3(15%) of the respondents strongly agree and disagree that radio lectures encourage learning and teaching among NCE II students.

The result in table above shows that 5(25%) and 7(35%) of the respondents strongly agreed that NCE II students where been taught using radio-lectures due to the breakout of Covid-19 due to the disease breakout. In view of this 6(30%) also agreed with this notion, while a lesser proportion 2(10%) of the respondents disagree that NCE II students where been taught using radio-lectures due to the breakout of Covid-19 due to the disease breakout.

The survey result in table above shows that most of the respondents 6(30%) and 4(20%) strongly agreed and also agreed that NCE II students where been taught using radio-lectures due to the fasteners of learning of Biology using radio-lectures, while 6(30%) and 4(20) strongly disagreed and disagree that NCE II students where been taught using radio-lectures due to the fasteners of learning of Biology using radio-lectures. The analysis of the above table shows that a total of 7(350%) and 4(20%) of the respondents strongly agreed and also agreed that NCE II students where been taught using radio-lectures due security reasons in the country, 6(30%) and 3(15%) of the respondents reveal that NCE II students where been taught using radio-lectures due security reasons in the country.

### **Conclusion**

From the analysis and the interpretation of data collected during the study, the following conclusions were drawn with regard to the above topic:

- a. It was revealed that difference between student academic achievement in Biology before and after radio lecture among NCE II students.
- b. It was also concluded that there is no awareness of radio Biology programmes among NCE II students in Federal College of Education, Zaria.
- c. Finally, NCE II students where been taught using radio-lectures due to the breakout of Covid-19 due to the disease breakout.
- d. NCE II students where been taught using radio-lectures due to the fasteners of learning of Biology using radio-lectures.

### **Recommendations**

- i. Government should permanent annual implementation of ICT Facilities in the study area for effective radio-lecture.
- ii. Ministry of education should implement teaching and learning with Information and Communication Technology in tertiary level curriculum.
- iii. Schools administration shouldn't be depending on government for the provision of ICT facilities to school.

### **References**

- Adeleye, G, (2010). *Evaluation of the effectiveness of radio health messages in the campaign against maternal mortality in Ogun State, Nigeria*. PhD Thesis in the Department of Mass Communication. Babcock University.
- Adeyemo, S, (2001). *Mass media and rural community development in Oso L. (ed) community media: Voices of the oppressed*, Abeokuta: Jedididah Publishers.
- Awotua-Efeboe, G, (2001). *Managing a radio station in an academic community: Experiences and lessons for upcoming community radios*, Unpublished paper presented at the National Seminar on Building Community Radio in Nigeria organized by Institute for Media and Society, held from 28th -29th November, 2013 in Kogi State, Nigeria.
- Baddeley, I, (2007). *Models and theories of communication, Maryland: African Renaissance, Books Incorporated*
- Bailaila, R. & Kvakadez, L. (2020). *Community Media: Voices of challenge and resistance*, from Below in Oso.
- Children and Technology (2014). *Radio programme production*, A manual for training Paris: UNESCO.
- Elliot, O. & Lashley, F. (2017). Language as a Predictor of Effective Communication: Relevance for Radio Broadcasting, *Babcock Journal of Mass Communication*.2(1) 138-149.

- EiEWG (2020). *Motion pictures and radio: Modern techniques for education*, New York: McGraw-Hill.
- Eccles, R, (2002). *Theories of human communication (9th ed)*, Wadsworth: Cengage Learning.
- Ekanem. T, (2006). Ismail's (2015). Development and mass communication: Effective use of the Mass Media in Rural (or Inner-City) Development in Moemeka A.A. (ed) Development Communication in Action Building Understanding and Creating Participation, ABraka. Nigeria, *Journal of Communication and Media Research*.
- Ekanem, S. I. (2006). *Lecture note on educational broadcasting and development communication*.
- Eyre, T. (2011). *A research project submitted to the department of mass communication, School of Education and Humanities*, In Partial Fulfillment for the Award of Bachelor of Arts (B.A. Rons) in Mass Communication.
- Eze, Z. (1992). *Community radio: A tool for development*, [http:// digicastmagazine.com /issue/february/artic\]e/community-radio-a-tooI-for-deveIopment#.U3YJALGLLIU](http://digicastmagazine.com/issue/february/artic]e/community-radio-a-tooI-for-deveIopment#.U3YJALGLLIU) accessed on Friday 16/5/2014
- FME,A, (2004). *Essentials of broadcast writing and production*, Lagos: Gabi Concept Ltd.
- Igboamauchey, E, (2014). *A Comparative Assessment of Student's Perception, of Campus Radio Programming in Nigeria. A study of Hope89.1 and Diamond FM Stations*. BSc Project in the Department of Mass Communication, Babcock University.
- Indabawa, B, (2010). Broadcast media policy in Nigeria: Across many dispensations, *African Communication Research*, 3(1) (2010).
- Kuewumi, J. B. (2009). *Radio: How it impacts the listener personally*, Babcock of Mass Communication. 2(1)
- Lashley, R, (2017). *Mass Communication theory: Foundations, ferment and future (3rd ed)*. USA, Wadsworth Thomson.
- Lashley, (2017). *Basics of radio and television broadcasting*, Abeokuta: Primus Prints & Communications.
- Leuders. Q. (2011). *Bridges to effective learning through radio*, Indira Gandhi National Open University, India. Accessed on Monday 2nd August, 2015
- Maduabum, B, (1998). *Federal communications commission*, 2011-03-03, Retrieved 2020-01-18.
- MGbefume, I, (1985). *Oxford living dictionaries*, Oxford University Press. 2019. Retrieved 26 February 2019.

- Musa, A. & Ismail, H. (2015). *Encyclopedia. PC Magazine website*, Ziff-Davis. 2018. Retrieved 26 February 2019.
- Muhammad, A. & Shuaibu, M. (2018). *Russian Satellite Communications Company*. Ocharo and Karani, N, (2015) *Electrical World*, June 22. 1907, 1270.
- Nigeria Broadcasting Code (2010). *National broadcasting commission 5th ed.*
- Ogunsanya, E. (2004). *Broadcast management and operations*, Lagos: Gabi Concept Ltd.
- Oluteye, Y. D. (2010). *Campus radio as a tool for promoting maternal and infant*.
- Okeke, T, (1986). Ezeh, D, (1992). UdejL II (2007). [www.etymonline.cqm](http://www.etymonline.cqm), Retrieved 2020-05-24.
- Okeke, X, (1986), 2016 Edition" (PDF). *International Telecommunication Union*. 3 November 2016. Retrieved 9 November 2019. Article 2, Section 1, p.27
- Okorie, V. (2004). *Union of Concerned Scientists*. 1 January 2021. Retrieved 21 May 2021.
- Okafor, D. (1999). *By Alexander Graham Bell Popular Science Monthly, July 1999*, "We have named the apparatus for the production and reproduction of sound in this way the "photophone". because an ordinary beam of light contains the rays which are operative. To avoid in future any misunderstandings upon this point, we have decided to adopt the term "radiophone", proposed by M. Mercadier. as a general term signifying the production of sound by any form of radiant energy..."
- Oyinyole, C. & Adeleye, Q, (2010). *Mass media and the society: Issues and Perspectives: Lagos Journal of Kagor International*.
- Udeji, R. (2007). *The electrical review (London)*, January 20, 1905, page 108, quoting from the British Post Office's December 30, 1904 Post Office Circular.





## Effects of Demonstration and Practical Activities on Students' Psychomotor Performance in Learning Biology Among NCE Students in FCE, Zaria

<sup>1</sup>Jibril Jamila, <sup>2</sup>Muhammad Maimuna Madaki & <sup>3</sup>Ibrahim Murja Danja  
Department of Biology,  
Federal College of Education, Zaria



### **Abstract**

*This study sought to determine the impact of practical and demonstrative approaches on students' psychomotor performance in learning Biology among NCE students in FCE Zaria, Kaduna State. To direct the investigation, two research questions and two hypotheses were developed. A 1,007 (one thousand and seven) sample of NCE II students was employed in the study, which had a quasi-experimental design with a pre-test, post-test, and control group. The Biology Achievement Test (BAT), which was taken from their biological practical guidebook, BIO 224, was the instrument used for data collection. Two departmental experts evaluated the face and content validity of the instruments. The Pearson Product Moment Correlation was performed to determine the instrument's reliability using the test-retest approach, and the instrument's reliability was determined to be 0.75 coefficients. Research topics were addressed using the mean and standard deviation. The 0.05 threshold of significance was applied to the hypothesis test using an Analysis of Variance (ANOVA) and independent t-test. The results demonstrate that students' psychomotor performance is enhanced when various instructional methodologies are combined with real-world activities as the outcome also demonstrates that there is a notable difference in the effects of demonstration and practical approaches on students' psychomotor performance in biology learning. Furthermore, the study found out that there was no significant difference in mean psychomotor performance of male and female students exposed to practical activities. To balance the theoretical and practical components of teaching biology, it was suggested that the government set up workshops, seminars, and training programmes for both biology instructors and lab personnel.*

**Keywords:** *Practical activities, Psychomotor, Performance & Lecture method*

---

## **Introduction**

Through theoretical and practical exercises, science is a methodical process of acquiring knowledge about nature that can be verified and tested. Scientific progress has touched and dominated every aspect of human activity over time, making it highly challenging for anyone lacking in scientific literacy to live in contemporary society. As science has become the foundation of an expanding workforce globally, it is crucial for any country to improve the quality of its educational system by establishing science laboratories in schools as a key component of a school science curriculum. This is because all students need a strong exposure to science (Biology) practical activities. The laboratory is the appropriate setting for this practical aspect of learning in any science subject, and biology is one of the science subjects that cannot be taught or learned effectively without practical activities. This is true for all students in order for them to achieve their career goals. According to Uche (2018), a scientific lab is a setting where students can pick up new information, ideas, and skills in order to comprehend laws, principles, laws, theories, and natural phenomena better. At all educational levels in Nigeria during the last few decades, student performance standards have decreased precipitously (Emaikwu, 2012). The reasons for Nigeria's deteriorating educational quality are many. According to Etukudo (2016), the problem could be related to the pedagogical techniques employed by teachers in the classroom. Salau (2019), who backed a similar viewpoint, claimed that students' poor performance on public exams can be attributed to teachers' use of inadequate teaching techniques. According to Ogunniyi (2019), poor teaching practises are one of the persistent and compelling concerns restricting accomplishment in Nigeria.

Inquiry-based learning, project-based learning, lecture performances, lecture demonstrations, problem-solving learning, field trips, cooperative or group learning, excursion-based learning, remedial learning, laboratory instruction, guided discussion, and video instruction are just a few of the methods that have been proposed for the teaching of science in schools (Adedoyin, 2010). Lectures and demonstrations have always been the primary modes of instruction in Nigerian classrooms. The lecture technique, according to Akem (2017), entails the teacher giving all the information she/he wants the students to comprehend but paying little to no attention to whether or not the students are actively participating and aiding the class in being successful. The vocal explanation and "doing" used in the demonstration approach help convey concepts, processes, and ideas. The demonstrative method of teaching is similarly based on the simple but reasonable notion that we learn best by "doing." A blended teaching strategy is one that incorporates two or more teaching and learning interaction patterns into the teaching and learning process (Iroriteraye-Adjekpovu, 2012). Biology is the study of life, including its diversity, interactions, origin, evolution, and processes. Additionally, it examines issues like disease and adaptation and, when appropriate, makes treatment suggestions, according to Levine and Miller (2012). However, biology is the field of study that makes use of scientific findings and methods to investigate life. Students are questioned using the inquiry technique to promote critical reasoning. This helps kids to acquire the scientific abilities and character traits—such as ingenuity, curiosity, and openness necessary for comprehending biological concepts. Biology offers chances for a variety of research approaches because it is the study of life. Biology can contribute to environmental protection by halting environmental deterioration, such as desertification, erosion, water hyacinth, and air, land, and water pollution. The primary goals of biology instruction are to prepare students to acquire the following skills: adequate laboratory and field biology skills; meaningful and relevant biology knowledge; the capacity to apply science to real-world issues in areas like agriculture and

individual and communal health; and, finally, reasonable and pragmatic scientific attitudes (Federal Ministry of Education, 2013). Biology students can learn useful concepts, theories, and abilities that will help them overcome challenges both before and after graduation. Practical biology is the scientific study of the life and structure of plants, animals, and their surroundings in a real or experimental situation rather than concentrating on theory and notions (Opuh, 2014).

According to Mkpa (2012), psychomotor skills are those aptitudes or specific competences that students can develop via regular rehearsal and application in performing human actions. (2017) Murrihy, Bailey, and Roodenburg Psychomotor skill development is evaluated according to the speed, distance, approaches, and strategies used in the performance of a process or the production of a good. Practise and measurement are required. This study aims to determine if lectures, demonstrations, or a hybrid approach of instruction will aid students in developing the psychomotor abilities used in practise activities during biology sessions. Effective training has a significant impact on performance improvement among other factors. Practical activities could be used in place of the abstract or theoretical presentation of factual notions and subject-specific conceptions to make training more approachable for pupils. In 2019, Nzewi and Okereke argue that practical exercises should involve hands-on, cognitive tasks and that a variety of teaching resources and instruments should be employed to enhance the lesson. Nwagbo (2008) argued that practical activities should be used to teach biological concepts as a rule rather than an option if biology teachers want to produce students who will be able to acquire the knowledge, skills, and competence required to meet the scientific and technological demands of the nation. Numerous definitions of the phrase "classroom laboratory" have been provided by various authors.

According to Shana and Abulibdeh (2020), a laboratory is where scientific instructors carry out experiments for the benefit of their students. Experiments and other activities that aid in the students' acquisition of scientific information and other crucial skills are part of the laboratory exercises. According to Ezeliora (2011), a science laboratory is akin to a workshop where activities related to science are carried out in a friendly environment. The availability and efficacy of utilising specialised and appropriate science equipment, facilities, and instructional materials, according to Ambibola (2011), is a critical component of science education that is of significant importance. On how well students succeed in a given area of Agricultural Science, the effectiveness of the treatment has a considerable influence. Comparing the demonstration technique to the lecture and peer tutoring strategies, Adekoya and Olatoye's (2011) research found that the demonstration strategy is the most efficient way to teach pasture and fodder science. The display method of instruction has a considerable impact on students' performance in Agricultural Science, according to research by Abdulhamid (2010). Additionally, a substantial difference between student performance in agricultural science lessons taught using the demonstration approach and those taught using the lecture method, favouring the demonstration methodology, was found in the study's findings. Agboola and Oloyede discovered a significant distinction between the inquiry methodology and the lecture demonstration method (LDM) employed for the chemistry practical test in their 2017 study. However, the study also revealed that the lecture demonstration technique greatly outperformed other instructional strategies in terms of student performance.

On achievement exams, students who acquired mathematics using the activity approach performed better than those who learned it using the discussion technique, the field method, and the lecture method. (2014) Akanyi. This suggested that, in terms of their performance on achievement tests, pupils taught mathematics using a variety of teaching methods and activity-based instruction differed significantly. Students who were taught utilising the demonstration method of education did better than those who were taught using the lecture method, according to Edu and Ayang (2012). Additionally, according to Edu, Ayang, and Idaka's (2012) research, students who were taught using the project instructional strategy did better on the psychomotor performance exam for fundamental electrical concepts than students who were taught using the demonstration teaching method.

### **Statement of the Problem**

Despite research attempts to help students do better in biology, society has consistently criticised biology instruction and learning as a result of students' subpar performance in external biology examinations. According to comments from biology chief examiners, applicants' performance in external examinations has dropped in recent years. This weakness was linked to students' inability to conceptually grasp some biology ideas as a result of insufficient exposure to practical work. Due to this circumstance, better teaching strategies are required in order to improve students' persistently subpar biology performance. This study was motivated by the biology students' consistently poor exam results and the graduates' lack of professional and marketable skills. Some analysts blamed the lecturers' instructional methods for the problem. This claim was supported by a 2012 report by the National Business and Technical Examination Board (NABTEB), which claimed that the employment of ineffective or improper teaching methods is one of the most probable causes of the high failure rate among college students. Similar to this, Onweh and Akpan (2014) suggested that lectures and demonstrations make up the majority of instructional strategies. This study examined how practical activities and demonstrations affected NCE students at FCE in Zaria's psychomotor performance when learning biology in light of these situations.

### **Objectives of the Study**

In particular, this study aims to accomplish the following objectives: -

- i. Determine the effect of demonstration and practical activities on students' psychomotor performance in Biology among NCE II in FCE, Zaria.
- ii. Examine the effect of practical activities on students' psychomotor performance in Biology among NCE II based on gender.

### **Research Question**

The following research question served as the basis for this study:

- i. What are the average pre-test and post-test psychomotor performance scores of NCE II Biology students who were taught in FCE, Zaria utilising a combination of lecture, demonstration and practical activities?
- ii. What is the difference in the mean psychomotor performance scores of male and female Biology students taught with practical activities only?

### **Hypotheses**

The following research hypotheses were tested at .05 level of significance:

- i. There is no significant difference in the mean psychomotor performance scores of

NCE II Biology students instructed using demonstration and practical activities in FCE, Zaria.

- ii. There is no significant difference between the mean psychomotor performance scores of male and female Biology students instructed using practical activities only.

**Methodology**

The research design used in the study was quasi-experimental. In particular, the pre-test-post-test control group design was not randomised. The researcher believes that this methodology is acceptable for this study since, if used, a real experimental research design that uses randomization to pick research participants would interfere with the college's academic programmes. Therefore, the study used entire classes. All NCE II Biology students at FCE, Zaria (1,007 total) make up the study's population. Because it is a second-year class and the students can engage because they have some experience with practical activities, the usage of this class is justified. The Biology Achievement Test (BAT), which was taken from their BIO 224 practical manual, served as the tool for gathering data for this study. Two top lecturers from the department have confirmed the instrument's look and content. The reliability of the instrument was found to be 0.75 coefficients utilising the test-retest method and Pearson's Product Moment Correlation Coefficient (PPMCC). ANOVA and t-test were utilized in analysing the data.

**Results**

The results were presented sequentially according to the research question and hypotheses.

**Research Questions One:** What are the average pre-test and post-test psychomotor performance scores of NCE II Biology students who were taught in FCE, Zaria utilising a combination of lecture, demonstration and practical activities?

**Table 1:** Mean Pre-test and Post-test Score of NCE Biology Students Instructed Using Lecture, Demonstration, and Practical Activities Teaching Method

Group	N	Pre-Test Mean Score	Post-Test Mean Score	Mean Gain Score
Lecture Method (Control group 1)	34	27.26	53.86	26.26
Demonstration (Control group 2)	29	25.89	84.66	58.77
Blended Method (Experimental group)	44	28.52	100.13	71.61

**Note:** N = Number of respondents

Table 1 summarized the mean (average) pre-test and post-test psychomotor performance scores of NCE II Biology students who were taught in FCE, Zaria utilising a combination of lecture, demonstration and practical activities, where lecture method has a mean of 26.26, demonstration has 58.77 and practical activities (Blended) has 71.61 respectively.

**Research Question Two:** What is the difference in the mean psychomotor performance scores of male and female Biology students taught with practical activities only?

**Table 2: Mean psychomotor performance scores of male and female students in**

Study Groups	N	Mean	Std. Dev	Mean Difference
Male	21	20.23	4.71	0.03
Female	23	20.26	4.91	

Results from the descriptive statistics in Table 2 revealed that difference exists between the mean scores of male and female students exposed to practical activities. The mean scores of male and female students exposed to instructional materials are 20.23 and 20.26 respectively with a mean difference of 0.03 between them. The slight difference of 0.03 was found between the male and female students who were taught Biology concepts using practical activities. This is an indication that learning biology concepts using practical activities improved the academic performance of both male and female students. In order to test if the difference in mean is significant for both male and female students taught Biology concepts using practical activities, the mean scores were subjected to hypothesis test at  $p \leq 0.05$  level of significance in Table 4.

**Hypotheses Testing**

**Hypothesis One:** There is no significant difference in the mean psychomotor performance scores of NCE II Biology students instructed using Lecture, demonstration and practical activities in FCE, Zaria.

**Table 3:** Analysis of Variance of Mean Psychomotor Performance Scores of NCE Biology Students Instructed using Lecture, Demonstration and Practical Activities in FCE, Zaria.

Variable	Sum of Squares	Df	Mean square	F	Sig.
Between groups	19899.81	23	865.21	0.93	0.58
Within groups	10189.17	11	926.29		
Total	30088.97	34			

The computed p value for Table 3 (0.58) was over the 0.05 cutoff, hence the null hypothesis was accepted. This implies that the mean psychomotor performance scores of NCE Biology students taught at FCE, Zaria utilising the lecture, demonstration and practical activity teaching modalities did not significantly differ from one another.

**Hypothesis Two:** There is no significant difference between the mean psychomotor performance scores of male and female Biology students instructed using practical activities only.



**Table 4: Summary of t-test statistics on difference in the Psychomotor Performance of Male and Female Students in the Experimental Group**

Study Groups	N	Mean	Std. Dev	df	t-cal	P	Decision
Male	21	20.23	4.71	81	0.02	0.98	Not Significant
Female	23	20.26	4.91				

*Not Significant at  $p > 0.05$*

The summary of the independent samples t-test in Table 4 shows a p-value of 0.98 was obtained which is greater than p value  $\leq 0.05$  set for acceptance or rejection of the hypothesis. This is an indication that there is no significant difference in mean psychomotor performance of male and female students exposed to practical activities. Thus, the hypothesis which stated that there is no significant difference between the mean psychomotor performance scores of male and female Biology students instructed using practical activities only is retained. This implies that teaching biology concepts using practical activities improves the psychomotor performance of both male and female students taught biology concepts thereby making the teaching method gender friendly.

### Discussion of Findings

The impact of the various instructional tactics utilised in this study was evident in the average score and average gain. Practical activities are the most successful kind of instruction, followed by demonstrations, while lectures are the least effective. The results of further investigations, including those by Akerele and Afolabi (2012), Jadal (2011), and Aggarwal and Mahajan (2012), are used to corroborate these conclusions. This research showed that there was a wide range in student performance and that media use improved performance. Furthermore, students who have received lectures along with audio-visual teaching resources do noticeably better. The ANOVA study also revealed that the mean scores of students who learned biological topics through lectures, demonstrations, and hands-on activities did not differ significantly from each other. These findings concur with those of Onasanya, Daramota, and Asuquo (2006), who found no discernible performance difference between students exposed to a customised CAI package and those exposed to the lecture mode of instruction. The findings of this study do not concur with those of Abdulhamid (2010) or Adekoya and Olatoye (2011), respectively. In their research, they found that the demonstration style of instruction significantly outperformed the lecture style of instruction in terms of student performance, which supports this claim. Contradicting the results of this study, Edu, Ayang, and Idaka (2012) found that students who were taught using the project instructional method outperformed their counterparts who were taught using the demonstration teaching method on the psychomotor performance test in basic electricity.

The study also discovered that there was no discernible difference between male and female students who participated in practical activities in terms of their mean psychomotor performance. The results confirm those of Onasanya and Omosewo (2011), who claimed that students of both sexes who were taught using instructional materials fared equally well. There wasn't much of a difference. The approach was gender neutral. Additionally, the data supports Muodumogu and Yisa's (2013) conclusion that gender has no discernible influence on students' academic performance in Physics. Furthermore, this outcome supports Dania's (2014) results that the interplay between gender and therapy and students' academic achievement does not affect students' performance.

## **Conclusion**

According to the study's findings, teaching strategies used by science instructors to help students grasp biological concepts have a good impact on their psychomotor performance. Additionally, it was found that combining various teaching strategies with practical activities improved students' psychomotor performance. This suggests that the use of practical activities in the classroom improves students' psychomotor performance when learning biological topics.

## **Recommendations**

According to the study's findings, it was suggested that:

1. In order to teach ideas that are skill-oriented, biology teachers should always integrate multiple teaching techniques.
2. The government should arrange training, seminars, and workshops for laboratory technicians as well as biology teachers in order to harmonise the theoretical and practical components of biology instruction.

## **References**

- Abdulhamid, A. (2010). Effects of two teaching methods on secondary school students' agricultural science performance in Bauchi metropolis Nigeria. *Journal of Research in Education and Society*, 1(1), 1-12.
- Abimbola, I. (2011). Fundamental principles and practices of Instruction Belodan (Nig) Enterprises and Tunde Baba Painters.
- Adedoyin, F. A. (2010). Teaching strategies in population education. In: Perspective in Population Education, Selected Readings in Population Education 2, National Education and Development Council (NERDC). Lagos, NERDC Press.
- Adekoya, Y. M. & Olatoye, R. A. (2011). Effect of demonstration, peer-tutoring, and lecture teaching strategies on senior secondary school students' achievement in an aspect of agricultural science. *The Pacific Journal of Science and Technology*, 12(1), 320-332.
- Agboola, O. S. & Oloyede, E. O. (2017). Effects of project, inquiry, and lecture – demonstration teaching methods on senior secondary students' achievement in separation of mixtures practical test. *Educational Research and Review*, 2(6), 124-132.
- Aggarwal, P. & Mahajan, N. (2012). A comparative study for effectiveness of use of audio visual aids in amphibian laboratory. *International Journal of Scientific & Engineering Research*, 3(12), 1-2.
- Akanyi, A. (2014). Teaching methods employed by secondary school mathematics teachers. An Unpublished P.G.D.E. Project. Benue State University Makurdi.
- Akem, I. A (2017). Practices and teaching methods. An unpublished lecture notes of the College of Education, Katsina–Ala Benue state.

- Akerele, J.A. & Afolabi, A.F. (2012). Effect of video on the teaching of library studies among undergraduates in Adeyemi College of Education Ondo. *Library Philosophy and Practice (e-Journal)*. Retrieved from <http://www.digitalcommons>.
- Dania, P. O. (2014). Effect of gender on students academic achievement in secondary school social studies. *Journal of Education and Practice*, 5(21), 45-60.
- Edu, D. & Ayang, E. E. (2012). Evaluation of instructional methods and aptitude effects on the psychomotor performance in basic electricity among technical students in Southern Educational Zone, Cross River State, Nigeria. [International Journal of Contemporary Iraqi Studies](#), 2(2), 118-123.
- Edu, D. O., Ayang, E. E. & Idaka, I. (2012). Evaluation of instructional methods and aptitude effects on psychomotor performance in basic electricity among technical students in Southern educational zone, Cross River State, Nigeria. *American International Journal of Contemporary Research*. 2(2), 117-123.
- Emaikwu, S. O. (2012). Assessing the relative effectiveness of three teaching methods in the measurement of students' achievement in mathematics. *Journal of Emerging Trends in Educational Research and Policy Studies (JETERAPS)* 3(4), 479-486.
- Etukudo, U. (2016). The effect of computer assisted instruction on gender and performance of junior secondary school in mathematics. *ABACUS Journal of Mathematics Association of Nigeria*, 27(1), 1-8.
- Ezeliora, R. (2011). A guide to practical approach to laboratory management and safety precautions. Daughters of Divine love congregations: Enugu: Divine Love Publishers.
- Federal Government of Nigeria (2013). National Policy on Education. NERDC Press.
- Iroriteraye-Adjekpovu, J. I. (2012). Blended teaching methodology for quality assurance in education for adult and youth of basic education systems in Nigeria. *DELSU Institute of Education Research Journal*, 18(1), 138-142.
- Jadal, M. M. (2011). A study of effectiveness of the audio visual-aids in teaching and learning of English at primary level in Z.P. primary schools of Solapur District. *Indian Streams Research Journal*, 1(5).
- Miller, K. R. & Levine, J. S. (2012). *Prentice hall biology*. New Jersey, U.S.A: Pearson Education Inc.
- Mkpa, N. D. (2012). Evaluating psychomotor behavior 1 in Nworgu, B.G. (ed). *Educational measurement and evaluation: Theory and practice*. Nsuka: Hallman Publishers.

- Muodumogu, C. A. & Yisa, T. A. (2013). Writing skills development strategies and junior secondary schools' achievement in composition. *Journal of the Reading Association of Nigeria (RAN)*, 14(1), 107-117.
- Murrihy, C. Bailey, M. & Roodenburg, J. (2017). Psychomotor Ability and Short-term Memory, and Reading and Mathematics Achievement in Children, *Archives of Clinical Neuropsychology*, 32(5), 618–630,
- National Business and Technical Examination Board (2012). *May/June 2002/2003 NTC/NBC examination report*. Benin City: Festa Printing Press.
- Nwagbo, C. (2008). Science, technology and mathematics (STM) curriculum development. Focus on problems and prospects of biology curriculum delivery. 49<sup>th</sup> Annual Conference Proceedings of STAN: 77-81.
- Nzewi, U. M. & Okereke, I. E. (2019). Teaching biology for industrial application: The need to maintain quality biology teaching. In: U. M. O. Ivowi (Ed.). *Education for functionality*. Ikeja: Foremost Educational Services Ltd.
- Ogunniyi, M. B. (2019). Science, technology and mathematics. *International Journal of Science Education*. 18(3), 267-284.
- Onasanya, S. A., & Omosewo, E. O. (2011). Effect of improvised and standard instructional materials on secondary school students' academic performance in Physics in Ilorin, Nigeria. *Singapore Journal of Scientific Research*, 1(1), 68-76.
- Onasanya, S.A., Daramola, F.O., & Asuquo, E.N. (2006). Effect of computer assisted instructional package on secondary school students' performance in introductory technology in Ilorin Nigeria. *The Nigeria Journal of Educational Media and Technology*, 12(1), 84-91
- Onweh, E. V. & Akpan T. U. (2014). Instructional strategies and students' academic performance in electrical installation in technical colleges in Akwa Ibom State: Instructional skills for structuring appropriate learning experiences for students. *International Journal of Educational Administration and Policy Studies*, 6(5), 80-86
- Opuh, B. (2014). The role of laboratory work in school science educators and students perspective. Retrieved from
- Salau, M. O. (2019). The effect of class size on achievement of different ability groups in Mathematics. *Journal Science of Teachers 'Association of Nigeria*, 31(1).
- Shana, Z. & Abulibdeh, S. E. (2020). Science practical work and its impact on students' science achievement. *Journal of Technology and Science Education*, 10(2), 199-215.
- Uche, S. (2018). *The science laboratory: An introduction, fundamentals of science laboratory*. Calabar: University of Calabar Press.



## Conflict-Induced Theory of Hunger and Malnutrition: X-raying the Socio-Political Dimensions to Food Insecurity in Third World Countries (A Case of Nigeria)

<sup>1</sup>Ojiya, Emmanuel Ameh, <sup>2</sup>Agya, Atabani Adi, <sup>3</sup>Achanya, Julius John  
& <sup>4</sup>Nev, Stephen Aondowase

<sup>1</sup>Ph.D Student, Food Economics, Centre for Food Technology and Research (CEFTER),  
Benue State University, Makurdi, Nigeria

<sup>2,4</sup>Department of Economics, Federal University, Wukari, Nigeria

<sup>3</sup>Department of Public Administration, Federal University, Wukari, Nigeria

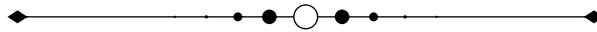

### **Abstract**

This study titled “Conflict-induced theory of hunger and malnutrition: X-raying the Socio-Political Dimensions to Food Insecurity in Third World Countries” (A Case of Nigeria) viewed conflicts between farmers, pastoralists and other terror gangs as the precursor for rising incidence of hunger and malnutrition in Nigeria. It is a qualitative analysis of how the unending cycle of violence by different terrorist groups against Nigerian farmers and farming communities had impeded the sustainable production of food for the nation's teeming population. Inferences from the study gave rise to the conclusion that apart from the socio-economic challenges that impede food security in Nigeria and other neighbouring countries, political factors such as conflicts, especially between farmers and non-state actors has been the harbinger for stagnated growth as well as low food production and thus food insecurity in these countries. The study thus recommends that, to remedy the challenge of food insecurity in third world countries, the government should go beyond addressing the socio-economic challenges that impede food security and as a matter of urgency understudy its peculiarities as it regards attacks by terrorists against farmers and farming communities towards adopting home-grown measures and remedies that would curb the menace to guarantee a more effective, enhanced, robust and sustainable food production for its teeming population.

**Keywords:** Conflict, Hunger, Malnutrition, Essay, Nigeria

---

## **Introduction**

The conflict-induced theory of hunger and malnutrition is a home-grown theory specially tailored towards addressing food security challenges in developing countries, with particular reference to Nigeria – a nation bedevilled by recurring crises among farmers-herders and other terror gangs whose launch-pad or base is always against farming communities across the country. The theory was proposed by Ojiya Emmanuel Ameh, a Ph.D Food Economics Student at the World Bank's Centre for Food and Technology Research (CEFTER), Benue State University, Makurdi, Nigeria. Developing this theory was in response to the weaknesses observed in Sen's Poverty and Famine Hypothesis: An Entitlement Approach. It is widely contended that contrary to the widely held view by Sen's (1981) Poverty and Famine theory, this study avers that, food insecurity in Nigeria and other developing countries was not as a result of only socio-economic factors as enunciated by Sen, but that food crises in most third world countries is precipitated or triggered by a combination of socio-economic and socio-political factors, such as the unending cycle of conflicts between farmers and non-state actors that has retarded food production and hence access in Nigeria and neighbouring African countries (Global Food Security Index (GFSI), 2021) and (FAO, 2021).

## **Literature Review**

While Sen's poverty and famine hypothesized that incidence of famine in many countries of the world was as a result of some socio-economic factors such as declining wages (incomes), unemployment, spiralling food prices, and poor food-distribution networks that resulted to starvation and malnutrition among citizens of such nations, realities in several third world countries, particularly Nigeria and its neighbours like Niger Republic, Cameroun, Senegal, Chad, Burkina-Faso, Benin Republic, to mention a few proved differently. This study views conflicts and other economic challenges such as rising unemployment, inflationary trend and poverty among others as being at the root of the growing food insecurity which undermine citizen's welfare in these countries.

## **Sen's Entitlement Approach and its Criticisms**

Amartya Sen's famine philosophy, popularly known as the 'entitlement approach to famine analysis' has generated irreconcilable controversies in the poverty literature. Entitlements, as defined by Sen (1984) refer to “the set of alternative commodity bundles that a person can command in a society using the totality of rights and opportunities that he or she faces”. Sen also viewed a person's “entitlement set” as the full range of goods and services that he or she can acquire by converting his or her “endowments” (assets and resources, including labour power) through “exchange entitlement mappings”. In the context of poverty and famine, the entitlement approach aims comprehensively to describe all legal sources of food, which Sen (1981) reduces to four categories: “production-based entitlement” (growing food), “trade-based entitlement” (buying food), “own-labour entitlement” (working for food) and “inheritance and transfer entitlement” (being given food by others). Individuals therefore face starvation if their full entitlement set does not provide them with adequate food for subsistence. Famine scales this up: occupationally or geographically related groups of people face famine if they simultaneously experience catastrophic declines in their entitlements.

## **Criticisms of Sen's Entitlement Approach**

Sen's poverty and famine theory are criticised on the grounds that, beyond his allusion to socio-economic factors as being drivers of hunger and famine among households, individuals



could experience food insecurity by (i) choosing to starve (ii) starvation or epidemics (iii) fuzzy entitlements (iv) extra entitlement transfers. These are discussed in greater details as follows:

- (a) Choosing to starve: Rationing one's own food consumption to protect assets and livelihoods beyond the immediate crisis is entirely consistent with a “multi-period entitlements analysis”. “Choosing to starve others” within the household requires an understanding of intrahousehold power relations that cannot be captured within the entitlement framework, which is severely undermined by the reality that those household members who make decisions concerning entitlements to food, and those household members who die during famines, are two distinct groups.
- (b) Starvation or epidemics? Although Sen's view of famine mortality as “death by starvation” or heightened susceptibility to hunger-related diseases is naive, de Waal's “health crisis model” does not refute a narrative of famine causation based on direct or exchange entitlement decline. Although increased exposure to disease might not be hunger-related, if this exposure is due to the social disruption triggered by a food crisis, then entitlement decline remains as the underlying cause of death. Conversely, if the social disruption is not caused by a food crisis (e.g. distress migration during a war), then this is not a famine at all.
- (c) Fuzzy entitlements: The existence of property regimes such as communal land tenure gives rise to two sets of “fuzziness” around entitlement relations: First, over the unit of analysis, and second, over the nature of property rights. Rights or claims over resources that are held collectively (by groups of people, or institutions) are incompatible with the entitlement approach, which is conceptually grounded in private property regimes, where resources are commoditized and owned by individuals.
- (d) Extra-entitlement transfers: The entitlement approach can be used to analyse the “normal” disruptive effects of war on local economies and livelihoods. It cannot, however, explain violations of entitlements such as requisitioning of grain, raiding of cattle and appropriation or withholding of food aid. Nor can it explain “unruly practices” such as deliberate starvation, or the use of famine as a weapon. “Complex emergencies” expose most sharply the limitations of what is essentially an economic analytical framework: its failure to engage with famine as both a social process and a political crisis.

All four limitations as discussed by Sen and scrutinized in this paper share two common underlying themes: First, a failure to recognize individuals as socially embedded members of households, communities and states, and second, a failure to recognize that famines are political crises as much as they are economic shocks or natural disasters. Thus Sen's Entitlement Approach dwelt essentially on the economies of famine, discarding the social or political dimensions or factors that precipitate famines.

### **Conflict-Induced Theory of Hunger and Malnutrition**

Given the preceding limitations of Sen's poverty and famine hypothesis, the conflict-induced theory of hunger and malnutrition came up with an opposing view on why hunger and famine occur in most developing countries. The theory postulates that hunger and malnutrition among households was predominantly conflict and crises-related and not just confined to Sen's emphasis on entitlements which were purely socio-economically related (Sen, 1981).

Consequently, this theory is an effort at advancing the frontier of knowledge in food economics, by evolving a more robust and an all-encompassing hypothesis that examines the factors that determine a nation's food security, from both socio-economic and socio-political dimensions. Particular is herein devoted to the salient but germane issues of conflicts and other forms of crises plaguing farming communities such as the age-long challenge between farmers and other terrorist groups (herdsmen, Boko Haram, Bandits/kidnappers) whose habitation majorly is on the same space that serves as farmlands to the farmers who grow the food consumed in Nigeria.

This was essentially developed as a framework towards finding solution(s) to the hunger incidences that is becoming glaring across the length and breadth of the country, due to low food production, leading to higher food prices and hence food insecurity. There is no belabouring the fact that low food production in Nigeria in more than two decades have been as a result of the unending cycle of conflicts and internecine crises between farming communities and nomadic / marauding herders; largely imported bandits, kidnappers and Boko-Haram terrorists groups, whose nefarious activities are having devastating effects on the entire Nigerian state, with food production being the major victim. Apart from causing untold economic stagnation to the country, these conflicts are imposing inexpressible hardships on all Nigeria farming communities. Several farmers as a result have been kept away from their occupation of food production and other agricultural activities and confined to internally displaced persons (IDPs) homes as permanent tenants for fear of being killed (Global Hunger Index (GHI, 2020) and Global Report on Food Crises (GRFC, 2021) and (Nurudeen et al, 2019).

#### **Assumptions of Conflict-Induced Theory of Hunger and Malnutrition**

The theory, according to the proponent is guided by the following assumptions:

- (i) That the adoption of improved technology such as improved seedlings, fertilizers, herbicides, tractors and other machineries for food production are necessary but not sufficient condition for a nation's attainment of her food security targets. The conflict-induced theory views the attainment of a country's food security potential as being preconditioned on the existence of a secured and safe environment for farmers to carry out their farming occupation without fear of intimidation;
- (ii) That because technological improvements alone devoid of a secured or safe environment is not enough to engender sustainable food production, it therefore presupposes that an unavoidable gap would be created between supply and demand for food products, whose effects would undeniably trigger higher food prices in the process;
- (iii) That the continuous push by nomadic herdsmen and armed bandits from their original abode in the North to the Southern coastal states of Nigeria in search of greener pastures is largely driven by the effect of climate change due to desertification and or desert encroachment including lack of rain;
- (iv) That while the remote cause(s) for the farmers-herders conflicts in Nigeria is linked to changing climatic conditions, such as irregular or reduced rainfall in the North, giving rise to a search for greener pasture and a more friendly habitation by these nomadic herders, an unbridled quest for land grabbing for grazing purposes is also at the heart of these conflicts; leading to more forceful displacement of farming communities and in the process affecting food production and Nigeria food security

- targets;
- (v) That the intensity and persistence of the conflicts between terrorists and other Nigerians is due to the high influx of foreign herders from neighbouring African countries like Cameroun, Chad, Niger Republic, Senegal, Mali, Libya, etc, which in the process has added to Nigeria's already growing population;
  - (vi) That the nefarious activities of this terror gangs as well as their continuous push towards the South of Nigeria is deliberately sustained due to the weak nature of our institutions (Immigration, Customs, the Military, Police, DSS, NIA, etc) that should enforce law and order in Nigeria
  - (vii) That the combined effects of the unending conflicts is a serious snag as well as a dent on the country's image and her investment prospects, with consequential decline in economic growth hence low per capita income and a weak purchasing power, with consequences for food insecurity among households'
  - (viii) That because the rampant and incessant nature of these conflicts can retard overall economic growth, it can equally result to widespread job losses thereby increasing or heightening the already unsustainable unemployment rate;
  - (ix) That the perpetuation of these conflicts can lead to other counter-cyclical effects if government continue to do nothing to halt or stop its continuance as it can create other cycles of violent crises or conflicts when the victims of terror attacks regroup to launch reprisal attacks, leaving Nigeria and indeed food production, comatose.

### **Study Methodology**

The conflict-induced theory of hunger and malnutrition is viewed from the precinct of challenges faced by developing countries, particularly Sub-Saharan African with a focus on Nigeria in their quest for food security. The study adopts a case-study qualitative research approach in its analysis.

### **Discussions**

Boko Haram and Fulani militias have all become a strong force today and are recognised globally as some of the deadliest terror groups in the world. They have attained a global notoriety for mass killings of both civilians and security personnel. The destabilizing effect of these terror gangs (herdsmen militia, Boko Haram, armed banditry/kidnapping) on both socio-economic and political physique of Nigeria is evident in their commitment to leaving a permanent and indelible scar on key sectors of the economy, with food production being the worse culprit (IEP, 2015), Burton, 2016).

It is heartrending and distressing to note that the largely Fulani herders and other terror gangs have as their primary objective, the forceful takeover and acquisition by compulsion, ancestral farmlands from mostly natives (especially the farming communities of North-Central, with particular attention on key farming States like Nasarawa, Plateau, Kogi and Benue State, which incidentally is the 'Food Basket of Nigeria'. Their unpatriotic exploits knows-no-bound; given that they also have their eyes focused on taking over, for their pasture and other yet-to-be known motives, large swatches of farmlands in the North-West, North-East, South-South, South-East as well as South-West. These regions are known for large scale cultivation of grains, tubers, cereals, palm oil, cocoa, to mention just a few (International Crisis Group, 2017).

With Nigeria immersed in pervasive insecurity, any prudent observer may fairly conclude that the country is best defined as a nation at war. This is despite the fact that defence receives an enormous budgetary allocation each year for maintenance and sustenance of peace, albeit with minimal results. In the true sense of the phrase, the carnage and related loss of lives and property caused by various forms of security issues characterizes the nation as conflict-ridden and a nation at war. Traditionally, the threshold for a struggle to be classified as a civil war is 1,000 battle dead (Nwozor, 2019), a figure which Nigeria has continuously surpassed even in excess of 1,000 as a result of different violent conflicts around the country by various terror gangs against the Nigerian state and its innocent and vulnerable population. Between 2010 and 2020, the Nigeria Security Tracker and the Armed Conflict Location and Event Data Project (ACLED) projected that between 55,261 and 88,530 persons died as a result of the Boko Haram and other related criminalities inflicted on the populace by non-state actors (Campbell and Harwood, 2018). All of these disputes and turbulence have a destructive effect on every area of the economy, with food production bearing the worst brunt of the carnage and damage.

For the armed bandits, their notoriety is evident in their zeal for mass killings, of largely local farmers. What began slowly in Kaduna, North-West Nigeria like a joke has today spread to almost every state in Nigeria, as they take refuge mostly in forests where they hatch and execute their deadly attacks. Their concentration in the Northern region is a clear signpost for food insecurity and hunger for the teeming Nigerian population. This is because over 90% of grains (maize, millet, guinea-corn) consumed in Nigeria is cultivated in States like Zamfara, Sokoto, Katsina, Kebbi, Kano, Niger, Taraba, Adamawa and Kaduna. Grain, incidentally is one of the commonest diet of an average Nigerian household with exportable surplus to neighbouring Cameroun, Chad, Niger Republic, Mali, Senegal, which themselves depend heavily on the giant of Africa for their food supplies. In all these, the Nigerian government through its various security agencies are casually looking away in 'helplessness' as if food production no longer matters. In fact, government seeming helplessness has been viewed by both locals and the rest of the world as tacit support for these brigands (International Institute of Tropical Agriculture) (IITA, 2019).

The Conflict-induced theory therefore asserts that Nigeria's current travails in food production is majorly battle-related and thus politically motivated and not just as a result of some other socio-economic factors. Infact, it is the contention of this theory that Nigeria is bedevilled by very serious supply-side related issues in her food production endeavour, caused majorly by the persistence of these conflicts (farmers-herders, Boko Haram, armed bandits and kidnapping for ransom) which has been the reason for higher food prices that has persisted between 2011-2023. These were the periods when these crises assumed a larger than life posture, with thousands of farmers slaughtered, maimed and displaced, making them permanent residents in internally displaced persons (IDPs) camps, and thus unable to farm any longer, as they themselves become dependent on government rationed food aid (Etim, et al, 2017 & Achumba, et al, 2013).

One major argument of the conflict-induced theory is the fact that the combine effects of the activities of Boko-Haram, Fulani Herdsmen, banditry and other auxiliary terrorists leading to widespread displacement of farmers from their farming centres was and has been a major reason for the consistent and persistent low food production in Nigeria, thus creating an



unavoidable demand-supply gap. Furthermore, the conflict which has refused to abate has also been the reason for the drastic fall in fishing activities and other livestock production in Nigeria. Given that their consistent attacks on local farmers has to a large extent grounded every meaningful engagement in agricultural activities, which is tilting Nigeria towards imminent hunger, starvation and famine (Ndubueze-Ogaraku, et al (2017) & (Ladan, et al (2020)).

It should be noted that majority of other Nigerian households depends largely on farming activities that takes place in Northern Nigeria for their livelihood. This is owing to the fact that the North is blessed with large expanse of arable farmland and the willing population to work, but lost its voice in food production when it became clear that going to farm was tantamount to signing one's death warrant. This is given the fact that farmers became ready targets for attacks as they were hounded and hunted by these blood-thirsty agents whose main objective, apart from the institutionalization of their own-version of Islam is the forceful take-over of farmlands for cattle and livestock grazing purposes. And because the federal authorities who owns and control key security outfits in the country either dithered, shilly-shallied and or under-rated these terrorists (killer herdsmen, armed bandits / kidnappers, Boko-Haram), they became emboldened, impudent, overzealous, audacious and impenitent, and so have continue to waste lives and plunder communities, and this is inspite of repeated government pleas to them to sheathe their swords and give peace a chance.

In fact, for the armed bandits, there is no limit to their operations, as yearly, apart from their killing expeditions; their agents levy heavy taxes and fines in millions of naira on hapless and helpless Nigerian farmers to be paid before-farming and another set of heavy levies to be paid before-harvest. In fact, payment of the former is a necessary condition for commencement of farming activities as they are considered levies required for granting farmers access to their own ancestral land. So pathetic is the lot of the average Nigerian farmer that the ongoing food scarcity has been long expected. An eventual famine too is not unexpected as thousands of farmers are already permanent residents in Internally Displaced Persons (IDP) camps in almost every State in Nigeria. The challenge of hunger, starvation and famine, painfully but surely and certainly stairs Nigeria in the face today because of government helplessness in taking charge of its territories which has become the harbinger of all forms of criminal activities, with devastating and unimaginable consequences on food production. This, sadly but painfully has put Nigeria on the map of acute food insecure countries, in dire need of food aid (Kah (2017), George, et al (2019) & Babagana, et al (2019).

According to the International Crisis Group, (ICG, 2022), statistics from all battle-related deaths across Nigeria from the combined activities of herders, Boko-Haramists, armed bandits and kidnappers is alarming and should be a source of worry to all policy makers in the country. Cumulatively, more than two million lives of predominantly farmers who remain soft targets have been either wasted or displaced across the length and breadth of Nigeria. This, however, is a very modest estimate as the reality could indeed be higher, given the heartlessness of these vampires who wield several high calibre assault rifles that the unarmed farmers cannot withstand.

### **Concluding Remarks**

This theory which extends beyond economic variables and viewed conflicts as some of the

socio-political factors that affects a nation's food security targets would accurately fit into food policy decisions in most developing countries as its assumptions are tailor-made to address conflict-related issues in several third world nations, with particular reference to Nigeria, where the occurrence of these crises has stagnated and or had adverse effects on general food production, hence meeting the country's food security objectives have remained scary. The theory presupposes that the unending insecurity in the Nigerian state is the leading determinant for the abysmal performance of the agricultural sector, with food production as the greatest victim. Thus, a wide supply-demand gap is created yearly, hence the higher food prices being charged.

Deriving from the revelations above, the study concludes that, contrary to the widely held view by Sen's (1981) Poverty and Famine theory, that only socio-economic challenges impede food security in nations of the world, the conflict-induced theory opines that socio-political factors such as conflicts, especially between farmers and non-state actors has been the harbinger for both stagnated economic growth and low food production and thus food insecurity in these countries. The study thus recommends that, to remedy the challenge of food insecurity in third world countries, particularly Nigeria and its neighbours affected by conflicts, the government should go beyond just addressing the socio-economic challenges that impede food security and as a matter of urgency understudy its peculiarities as it regards attacks by terrorists against farmers and farming communities towards adopting home-grown measures and remedies that would curb the menace to guarantee a more effective, enhanced, robust and sustainable food production for its teeming population. It further recommended as follows:

- (i) Government and the private sector should collaborate towards evolving global best practices in livestock management, such as grazing reserves and or ranching to reduce the conflicts associated with roaming or wandering of animals into people's farms.
- (ii) Smart food systems or agricultural techniques that are resilient to the effects of climate change should be adopted to ensure sustainable food production in Nigeria.
- (iii) The Nigerian government should involve the mass media, community leaders and religious bodies on sensitization/campaigns to farmers and pastoralists on best practices so as to reduce the recurrent conflicts between pastoralists and farmers as well as ameliorate the tide of global warming, which is already affecting food production in Nigeria.
- (iv) The Nigerian government should involve the mass media, community leaders and religious bodies on sensitization/campaigns to educate the citizens on population management;
- (v) Creating formal employment opportunities and income-generating activities for all qualified Nigerians holds the potential for deescalating tensions (insecurity) across the country. It will also further empower households to have adequate access to nutritious food, thus making them food secured.
- (vi) To reduce the incidence of rising food inflation, the Nigeria government should evolve policies that will strengthen the country's agricultural base for improved output which can boost food production with a viewing to reducing the current spirals in food prices.



## References

- Achumba, I. C., Ighomereho, O. S. & Akpo-Robaro, M. O. M (2013). Security challenges in Nigeria and the implication for business activities and sustainable development. *Journal of Economics and Sustainable Development*, 4(2), 34-52.
- Burton, G. (2016). *Background report: The Fulani herdsmen*. Retrieved from <https://medium.com/gfburton/background-report-the-fulani-herdsmen-part-i-key-findings-introduction-and-history-383c10f8137c>
- Etim, E. E., Duke, O. O. & Ogbinyi, O. J. (2017). The implications of food insecurity, poverty and hunger on Nigeria's national security. *Asian Research Journal of Arts and Social Sciences*, 4(2), 1-10.
- FAO (2021). *World food situation*. FAO Food Price Index. Sourced from [www.fao.org/worldfoodsituation/foodpricesindex/en](http://www.fao.org/worldfoodsituation/foodpricesindex/en)
- George, J., Adelaja, A. O. & Weatherspoon, D. D. (2019). Armed conflicts and food insecurity: Evidence from Boko Haram's attacks. *A publication of Michigan State University Department of Agricultural, Food and Resource*, 205 Morrill Hall of Agriculture, 446 West Circle Drive, East Lansing MI, 4882
- Global Food Security Index (GFSI, 2015)*. An annual measure of the state of global food security. *The economist intelligence unit*. Retrieved from <https://impact.economist.com/sustainability/project/food-security-index/>
- Global Hunger Index (2020). at [www.globalhungerindex.org](http://www.globalhungerindex.org). Publication Date: October,2020.
- IEP (Institute for Economics and Peace). (2015). Global terrorism index 2015: Measuring and understanding the impact of terrorism. Retrieved from [https://reliefweb.int/sites/reliefweb.int/files/resources/2015%20Global %20Terrorism%20Index%20Report\\_0\\_0.pdf](https://reliefweb.int/sites/reliefweb.int/files/resources/2015%20Global%20Terrorism%20Index%20Report_0_0.pdf)
- International Crisis Group (2017). Herders against Farmers: Nigeria's expanding deadly conflict. <https://www.crisisgroup.org/africa/west-africa/nigeria/252-herders-against-farmers-nigerias-expanding-deadly-conflict>
- International Institute of Tropical Agriculture (2019). Pressing challenges to food security in Nigeria and ways forward. Retrieved from [blogs.iita.org/index.php/pressing-challenges-to-food-security-in-nigeria-and-ways-forward/](http://blogs.iita.org/index.php/pressing-challenges-to-food-security-in-nigeria-and-ways-forward/)
- International Crisis Group, ICG (2022) Herders against farmers: Nigeria's expanding deadly conflict. *Crisis Group Africa Report No. 357*
- Kah, K. H. (2017). Boko haram is losing, but so is food production: Conflict and food insecurity in Nigeria and Cameroon. *Africa Development*, XLII(3), 177-196.

- Ladan, S. I. & Matawalli, B. U. (2020). Impacts of banditry on food security in Katsina State, Nigeria. *Direct Research Journal of Agriculture and Food Science*, 8, 2354-4147.
- Ndubueze-Ogaraku, M. E., Etowa, E. B., Ekine, D. & Familusi, L. C. (2017). Analysis of insecurity *shocks and farmers' resilience in the Niger Delta Region, Nigeria*. Nigerian Agricultural Policy Research Journal, 2(1).
- Nurudeen, A. M. & Shaufique, F. B. A. S. (2019). Determinants of food security among households in Nigeria. *Pakistan Journal of Nutrition*. DOI: 103923/pin.2019.1042.1052
- Nwozor, A., Olarewaju, J. S. & Ake, M. B. (2019). National insecurity and the challenges of food security in Nigeria. *Academic Journal of Interdisciplinary Studies*, 8(4).
- Sen, A. (1981). *Poverty and famines: An essay on entitlement and deprivation*. Oxford University Press.
- Sen, A. (1986). *Food economics and entitlements*. Helsinki: WIDER Working Paper 1, World Institute for Development Economics Research of the United Nations University.



## Food Security: Processing, Utilization and Households' Welfare in Nigeria

<sup>1</sup>Ojiya, Emmanuel Ameh, <sup>2</sup>Abu Maji, <sup>3</sup>Asom, Simeon Terwuah, <sup>4</sup>Samuel, Paabu Adda  
<sup>1</sup>Food Economics, Centre for Food Technology and Research (CEFTER),  
Benue State University, Makurdi, Nigeria;  
<sup>2,4</sup>Department of Economics, Federal University, Wukari, Nigeria;  
<sup>3</sup>Benue State University Makurdi, Nigeria

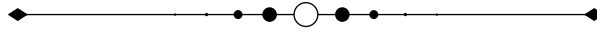

### **Abstract**

*The main objective of this study was to determine the effect of food processing and utilization on the food security aspirations and welfare of Nigerian households, using Nigerian data. The study utilized econometric techniques and based its framework on Sen's Poverty and Famine hypothesis. It was found that an individual or household's constant and lower calorie intake undermines their nutritional dreams, hence exacerbating food insecurity in the process. It was also discovered that the cost of sourcing for kerosene fuels remained the main constraint for the majority of households in the country. This is given the fact, that the average Nigerian household's poor purchasing power had incapacitated them; hence they lacked the financial muscle to continue purchasing kerosene fuel at exorbitant prices, with adverse consequences for processing and hence food security. Deriving from the foregoing, the study recommended that government should evolve poverty reduction strategies, including promoting income generating strategies that can transit a chunk of the unemployed to persons with income to command adequate access to their food needs. Furthermore, for Nigeria to overcome the incidence of food insecurity, the focus should be on curtailing corrupt practices, particularly in the oil industry towards making cooking fuels affordable to every household.*

**Keywords:** Food security, Processing, Utilization, ARDL, Nigeria

---

### **Background to the Study**

Food is a universal human right, with no known substitute, thus Woolf (2016) stated that, "one cannot think clearly, reason well, love well, or sleep well until one has dined properly." This remark underscores the imperativeness of food to man, hence mankind faced with the dilemma of food insecurity from time immemorial, has continued to strive to achieve food sufficiency through different agricultural policy initiatives. This is given the fact that a deficit in food sufficiency which triggers food insecurity portends a great danger / threat to the existence of countless households. Accordingly, the United Nations Food and Agriculture Organization, views food security as a condition or a state in which every person (families, local government, state and the nation) have unhindered and unobstructed physical, social, and economic access to enough, safe, and nutritionally-inclined food which guarantees their dietary requirements for an active, energetic and productive life. This implies that food insecurity refers to the absence or lack of access to enough, safe, and nutritionally-inclined food for an active, healthy and productive life (FAO, 2002; Barrett, 2002). Food security is commonly understood to comprise four important components: food availability, food access, food consumption (usage), as well as a constant and sustained assurance of access to it.

The United Nation's Food and Agricultural Organization (FAO, 2019) estimated that 842 million people globally are undernourished; out of which an estimated 98 percent are said to be living in developing or third world countries, with South Asia presently having the highest total figure of the undernourished, estimated at 295 million hungry persons, whereas the countries of Africa collectively has the biggest concentration of food insecure persons of any region. Food insecurity affects more than 2 billion people worldwide, with 1.03 billion living in Asia, 675 million spread across the Africa continent, 205 million persons distributed across Latin American countries and the Caribbean, while 88 million of these hungry people are in Northern America and Europe, with 5.9 million in the Oceania. To be concise, the vast majority of the world's hungry people are largely residents of poor countries, which as it were, accounts for 12.9 percent of the global population of the malnourished, daily in search and yearning for the true definition of food to be actualized in their lifetimes (FAO, IFAD, UNICEF, WFP & WHO (2020).

Despite policies articulated by global food agencies such as the International Food Policy Research Institute (IFPRI), the International Institute for Tropical Agriculture (IITA), the International Fund for Agriculture Development (IFAD) and the International Institute for Sustainable Development (IISD), food insecurity has remained on the rise in Nigeria. This is given the fact that the various agricultural initiatives and interventions have remained less effective, hence food insecurity has remained high in Nigeria; as revealed in negative effects on access, usage, and stability of access, hence a drop in households' welfare (Babatunde, Omotesho and Sholotan, 2007). Even where these food policies are deemed effective, food insecurity has remained intractable, as households quest to meet their food security aspirations has remained largely unresolved; given that the dimension of food processing and utilization has remained bleak. Several studies have been carried out to investigate the relationship between food processing, utilization and the welfare of households, with some believing that different socio-economic and political factors are responsible for households' inability to meet their basic and desired food needs. It is noteworthy that food processing and utilization are at the core of every food security discourse. This assertion is buttressed by the fact that every household's goal/objective in food studies is the expectation of an assurance or

guaranteed utility, derivable by consuming the needed food combinations that meets their dietary requirements for a healthy living and productive lifestyle. Thus, the loss of economic power coupled with other socio-political problems that hinder the attainment of households' food security aspirations, according to Sen (1981), are expressed in reduced food production, access, usage, which culminates in the adoption of several food coping strategies, climaxing in food rationing, hunger and malnutrition and hence calorie deficiency among such households.

However, the magnitude of these distortions principally occasioned by lack of economic power such as lack of access to cooking gas (fuel), safe water/sanitation, low purchasing power due to a vicious and an unending poverty are factors that undermine an individual's food use. These challenges differ in most developing countries, most notably Nigeria, which justifies this study, as stemming this cankerworm will improve several households' food processing and utilization capabilities leading to improve citizen welfare. Consequently, in the light of the foregoing, the most pressing economic policy option is to evolve ways to lessen the negative consequences of food insecurity on households' welfare, hence to this connection, the problematic of this research is to evaluate the extent of food processing and utilization on the welfare of Nigerian citizenry. There is dearth in literature on this problematic, given that, to the best of the researcher's knowledge no such work exists in this regard for Nigeria and as such this research is undertaken to fill this knowledge gap. Deriving from the foregoing, this study's main objective is to assess food processing, utilization and households' welfare in Nigeria between 1999 to 2021, while addressing the following specific objectives: (i) to examine the extent to which the determinants of food processing and utilization had significantly impacted households' welfare in Nigeria (ii) to examine the extent to which food processing and utilization and hence households' welfare had been impacted by poverty in Nigeria.

## **Conceptual Clarification**

### **Food Security**

There are two ways to look at food and nutrition security: self-sufficiency and the ability to manage risk and vulnerability in food and nutrition supply. According to (IFPRI, 2004), for a long time in the 1970s and 1980s, the term "food security" referred solely to a country's ability to produce enough food to feed its population. Four fundamental pillars underpin food security: food availability, food access, food consumption, and food stability, which imply removing the potential that any shock may cause any of the first three dimensions or pillars to be disrupted in any way. While food availability is required, it is not a sufficient condition for food accessibility, just as food accessibility alone cannot suffice without consumption. Food security is mostly determined by two variables. These include guaranteeing enough food supply and, secondly, ensuring that households suffering from undernutrition or malnutrition have the opportunity to access food, either via self-production or by the ability to purchase it. As a result of the disagreements and divergent views expressed by various scholars regarding the definition of food security, this study adopts, as its working definition and hence views food security as a fundamental human right, and the ability and / or capacity of all people, to have unfettered access to a sufficient, safe, and nutritious food combination that satisfies, guarantees, and meets their food preferences and dietary needs for an active and productive life at all times, regardless of their financial means, as they could fall back on food aid.

## **Food Security Dimensions**

### **Food Availability**

According to Oni and Fashogbon (2013), food availability refers to the amount or stock of food that households, communities, states, geopolitical areas, and nations have at any one moment. It is primarily influenced and guided by domestically produced foods, imported foods, food aid / assistance, and other demand and supply elements in food production, as well as the underlying causes of each of these aspects (FAO, 1996). Food availability is defined as the availability of sufficient quantities of food to all persons within a given country on a regular and consistent basis. Food availability, according to this study, refers to the accumulation or stock of food accessible in a given home, community, local government, state, or nation, which is attainable through domestic food production activities, food aid from donor organizations, or open importation from overseas. Food availability is sometimes confused with food access, as it can apply to both household and aggregate food supply. Although it should be noted that food availability is a poor indication of food security because it does not account for disparities in food access, the average daily calorie consumption per person does provide some insight into a country's overall food situation (Kidane, Maetz & Dardel, 2006).

### **Food Access**

On the other hand, food accessibility refers to a household or nation's capacity or ability to have easy access to accessible food supplies at all times, given the income at their disposal. Access to food is mostly a demand-driven issue. Consumers' or households' access to food is contingent upon their available money and the cost of the foodstuff in question (FAO, 1996). These elements are influenced by the household's resource endowment, which specifies the range of productive activities available to achieve income and food security objectives (Kidane, et al, 2006). Food accessibility is governed globally by four critical factors: economic, physical, political and sociocultural influences.

### **Food Utilization**

Food usage is a concept that refers to the quantity and quality of food that a household consumes in order to fulfill its nutritional and/or dietary requirements. A good dietary environment, also referred to as proper food use, connotes the presence of suitable and appropriate food processing and storage systems, acceptable and adequate knowledge of nutrition and child-rearing techniques, and access to suitable public health and sanitation services such as cleanliness and hygiene (FAO, 2000; Food and Nutrition Technical Assistance Project (FANTA), 2006). Food usage extends beyond the quantity of food consumed to the quality of food products consumed, since quantity alone does not equate to well-nourished households. Malnutrition is almost always the result of underutilization of available and accessible dietary combinations. This can manifest as stunting, sickness, or even obesity. However, this research study interprets food utilization differently and so adds that food use, as the end goal of the food production discourse, is the capacity of households to consume quality food of all categories or types required for their diet and a healthy living. To ensure total food utilization, end users must have access to a variety of processing and storage methods for their food in order to maintain its shelf life and avoid contamination. Additionally, this study asserts that Nigeria's desire for continuous food consumption is defined or assured by the behavior of the following elements: the cost of cooking gas; calorie intake and the poverty rate among the citizens in that nation.



### **Stability of Food Access**

Food access stability connotes that households are not at risk of losing access to food due to unforeseen shocks induced by changes in weather conditions or other crises or cyclical occurrences such as seasonal food insecurity (Olarinde, Abass, Abdoulaye, Adepoju, Adio, Fanifosi & Wasiu, 2020). It is expected that causes of food insecurity will grow more frequent in the future, particularly as a result of climate change. This is due to escalating climate change and the impact of global warming, which has resulted in regular temporary food shortages and strains on existing resources, leading to political turmoil. Furthermore, the climate-induced migration of herders and their cattle throughout Nigeria in search of food and feed usually leads to violence. Conflicts over scarce resources such as water and land, as well as migration due to drought, may become more frequent and extreme as a result of climate change, increasing the risk of food poverty and malnutrition (Oni et al, 2013). However, it is the contention of this study that food stability or access stability refers to the continuous assurance that households, communities, states, and nations have that their food needs will always be met, regardless of external threats such as income loss (unemployment or underemployment), poverty, or political violence. Unfortunately, food security in Nigeria has become a problem for policymakers, given the present degree of insecurity in the country's key farming areas. This is in addition to the growing threats posed by unavoidable changes in climatic conditions as a result of global warming's devastating effects, which have resulted in unstable rains, flooding of agricultural products due to torrential rainfall, and a recurring incidence of excessive heat waves, which are detrimental to the yield of a variety of agricultural products. These undesirable events wreak havoc on food production. It is important to remember that food security objectives can only be achieved when all four elements of food security are met concurrently.

### **Households' Welfare**

The term "household" refers to the fundamental residential unit in which economic output, consumption, inheritance, child-raising, and housing are structured and conducted. It is not always synonymous with household. In many social, microeconomic and government models, the home serves as the fundamental unit of study. The notion encompasses all those who share a residence. Household welfare and standard of living can be measured in terms of wealth, income, the quality and availability of employment, comfort, material goods and necessities available to households, the number of vacation days available per year, class disparity, poverty rate, life expectancy, disease prevalence, the cost of goods and services, the quality and affordability of housing, as well as the hours required to purchase a home; this is according to the United Nations Development Index (2013); (Moratti & Natali, 2012). For this study, household welfare is defined as the aggregate happiness or value that individuals, households, or communities obtain from the consumption of certain bundles of products (food) or services, given their available financial resources. It is a state of well-being, pleasure, and comfort, or the degree of prosperity and standard of living achievable by an individual or a group of individuals as a result of the satisfaction gained from their income and consumption of certain bundles of commodities (food inclusive). An excellent example of welfare is having access to the food combinations necessary to maintain a healthy lifestyle for a person or household, given the purchasing power available at the time.

## **Theoretical Review**

### **Sen's Theory of Poverty and Famine: An Essay on Entitlement and Deprivation**

This theory propounded by Sen (1981) tied its arguments to the fact that hunger and famine for a very long time have been largely rooted in postulations made by Thomas Malthus' food availability approach. Sen did not contribute to challenging Malthus (1798)'s stance on food security until the early 1980s, when attention was shifted from national food availability to people's access to food in a dissertation on "entitlement and deprivation". The emphasis on food security in the entitlement discourse was an insistence on each individual's entitlements to commodity bundles, including food, by viewing famine as a result of households' failure to be entitled to the bundle(s) that assures them of sufficient food to improve their welfare (Sen 1981). Sen's Poverty and Famine Hypothesis which examined the socio-economic factors that influences food insecurity among nations, due to the robustness and logicity of its assumption is considered as the theory that best provides answers to the discourse on food security and households' welfare in developing countries, particularly Nigeria, hence it is adopted for this study.

## **Review of Related Literature**

In line with this study's objectives, the following literatures are reviewed as follows: Firstly, Owoo (2021) examined demographics and food security in Nigeria from 1970 to 2018, employing data from three waves of the World Bank's Living Standard Measurement Survey for Nigeria in fixed effects regressions to show spatial trends in food security in the country. Larger households, according to their findings, have poorer food security outcomes and are more likely to report being food insecure than smaller households. It is also well recognized that children from large families are more likely to suffer from malnutrition. This link was substantial in urban Nigeria, as it was in rural Nigeria, with implications for sustainable urban development and household planning with the goal of meeting unmet contraceptive need. Similarly, Fadarele, Akerele, Mavrotasl, and Ogunniyi (2019) evaluated the relationships between conflict, food price shocks, calorie consumption, and acute malnutrition among children using a cross-sectional survey and fixed-effect and random-effects models within a panel framework. Their research, which was presented at a conference, demonstrated that increased food prices, particularly staples, had a lowering effect on calorie intake, hence raising the risk of acute malnutrition. The study recommended that a guided food pricing strategy and conflict prevention be implemented to ensure adequate calorie intake and nutrition outcomes, as well as consideration of other nutritionally linked aspects that contribute to a higher reduction in wasting prevalence.

Furthermore, Onunka, IHEMEZI, and Olumba (2018) used descriptive and inferential statistical approaches to analyze rural households' coping strategies against food insecurity in Enugu State's Udi Local Government Area from 2000 to 2016. Households were classified according to their level of food security (food secure and food insecure). The study's findings indicated that the two groups of households had significant differences in a number of socioeconomic factors. As a result, research established that the vulnerable households' coping mechanisms were not mutually incompatible; rather, a mixed approach incorporating various tactics was used to buffer food insufficiency shocks. The report advocated for more focus on education, poverty alleviation programs, and the creation of sustainable off-farm work alternatives to help customers earn an income. In another primary data survey, Muhammad-Lawal, Ibrahim, Oloyede, Belewu, and Adesina (2017) utilized a random utility

model to fit the collected data, which was then analyzed using the household Dietary Diversity Score (DDS), Analysis of Variance (ANOVA), and Multinomial Logit Regression (MLR) technique to assess the factors that influence rural households' dietary diversity behavior, as well as the relationship between dietary diversity and food calorie consumption among rural households in Kwara State, Nigeria. It was discovered that in the medium term, dietary diversity category, age, household income, gender, and education level were the socioeconomic characteristics that were beneficial in describing the respondents' dietary variety attitude. Based on the findings, the study recommended that enlightenment efforts on family planning, food-aid intervention, and nutrition education be expanded in order to produce a recommendable dietary formula that improves human health status in the study area.

Additionally, Fawole, Ibasemis, and Ozkan (2015) used econometric techniques to conduct a time series survey in Nigeria from 1990 to 2014 and explored the trend in food insecurity and its consequences for the country's stability over time. Critical food security indicators in Nigeria, such as the incidence of malnutrition, food insecurity, and the number of undernourished individuals, all increased between 2009 and 2014. Consequently, the continuance of this trend would eventually become a ticking time bomb, posing huge security dangers and threats to both the country and the African sub-region as a whole, given that it is by far the most populous black nation on the earth. To avoid this, several recommendations were made, one of which stated that the study's immediate causes of rising food insecurity should be addressed by implementing appropriate measures such as increased food production, infrastructure provision, and population control in order to address Nigeria's and other African countries' food security challenges.

Furthermore, Imonikebe (2010) also employed the use of percentages, mean, standard deviation and variance of the responses to explore the limitations to food security and its attendant effects on Nigerians. Using questionnaires administered on the population of Agricultural Science teachers, lecturers, students, farm managers, Home Economists, Nutritionists and literate farmers from four states in Nigeria from which a sample of 320 was randomly selected, the study found that some of the constraints to food security are poverty and households low purchasing power, which hamper their food security aspirations, leading to food insecurity, malnutrition, poor health outcomes, high mortality rate and low life expectancy as a consequence. Owing to the preceding outcome, the study recommended that Nigeria should adopt and implement food security measures adopted by developed countries to lessen the incidence of food insecurity among its citizens. In the same vein, cooking energy was viewed to have remained a critical component of life for the survival of any home on a daily basis as man must eat in order to survive. Consequently, Olugbire and Aremu (2016) explored the factors of household cooking energy choice in Oyo State, Nigeria, using a structured questionnaire to collect data from 130 households. Using descriptive and inferential statistics, they discovered that while fuel wood, charcoal, kerosene, gas, and electricity were the most frequently used cooking energies by households in the study area, that is, kerosene was the cooking energy of choice for many households, without which cooking was difficult. While homes with a high monthly income frequently chose gas and electricity with kerosene as a backup, households with a low monthly income frequently chose fuel wood, charcoal, and kerosene. Therefore, it was recommended that the government provide means to improve the welfare and standard of living of households in the study area,

enabling them to afford gas and electricity as a cooking energy source, thereby protecting them from the harmful effects of charcoal, fuel wood, and stove use.

Finally, applying MATLAB methods to conduct descriptive and inferential statistics and percentage difference between used and preferred energy, Emagbetere, Odia and Oreko (2016) randomly sampled 250 houses in Ikeja, Lagos State, Nigeria, to measure household cooking energy. Their survey discovered that kerosene and liquefied petroleum gas (LPG) were the most used fuels for daily cooking (48.60 percent and 36.30 percent, respectively). Only a minority of respondents, 7.10%, 5.7 percent, and 2.4 percent, respectively, used charcoal, firewood, or electricity for regular cooking. However, gas had the highest preferred rating for domestic energy, followed by electricity, kerosene, charcoal, and firewood. Additionally, empirical data from the chi-test, linear-by-linear connection test, and likelihood ratio test demonstrated that income level, level of education, and kind of work all influenced the type of cooking fuel utilized and chosen.

**Methodology**

The utilization of the Auto-Regressive Distributed Lag (ARDL) technique is adequate for this study given that it is secondary data-based analysis with a small and finite size of the data. Pesaran, Shin, and Smith (2001) alluded to gains of this technique as it utilizes mixed order of integration but not of I(2) and beyond. This technique also enables simultaneous estimation of long run association amongst variables of interest, in the determination of long and short run estimates. The validity and forecasting strength of the model will also be determined via tests of heteroscedasticity, autocorrelation and model misspecification.

**Model Estimation**

**Theoretical Framework**

This research model is based on Sen's (1981) theory of Poverty and Famine and is derived from Sen's proposition that the causes of food crises and famine in many countries around the world are not simply a result of a food supply gap but also as a result of several other socio-economic factors, including declining wages (income), poverty, cost of cooking gas and calorie deficiency. The theoretical model is as represented below:

**Model 1: Food Processing / Utilization Determinants and Households' Welfare in Nigeria**

$$Hwelfare = f(FUT) \dots\dots\dots (Eqtn 1)$$

$$\text{But } FUT = f(C_{GAS}, CAL_{DEF}, SWS, LEXP, POV) \dots\dots\dots (Eqtn 2)$$

By substitution of FUT into equation (4.13) we have

$$Hwelfare = f(C\_GAS, CALO, DEF, SWS, LEXP, POV) \dots\dots\dots (Eqtn 3)$$

**Specification of the Empirical Models**

To estimate the models above, the study utilized a simple ordinary least squares regression technique. This is given the fact that all the variables included in the models were level stationary series, that integrated of order zero I(0). Econometric theory suggests that where variables in a model are all at level order I(0), an OLS estimate could suffice. Thus, the

decision was arrived at owing to the uniform order of stationarity for all the variables included in the models (1) and (2). Therefore, the preceding equations are re-specified in their explicit form as follows:

$$\Delta Hwelfare = \alpha_0 \beta_1 C_{GAS} + \beta_2 CALO - DEF + \beta_3 SWS + \beta_4 LEXP + \beta_5 POV + \mu_t \dots (Eqtn 4)$$

Where:

- C\_GAS = Cooking gas
- CALO\_DEF = Calorie deficiency
- SWS = Safe water / sanitation
- LEXP = Life expectancy at birth
- POV = Effect of poverty
- $\mu_t$  = Stochastic error term / time trend

While  $\alpha_0 + \beta_1$ ,  $\beta_2$ ,  $\beta_3$ ,  $\beta_4$  and  $\beta_5$  respectively are the parameter estimates

The ARDL transformation for Equation 4.31 is stated as follows:

$$\begin{aligned} \Delta Hwelfare = & \alpha_0 + \beta_1 C_{GAS_{t-1}} + \beta_2 CALO_{DEF_{t-1}} + \beta_3 SWS_{t-1} + \beta_4 LEXP_{t-1} + \beta_5 POV_{t-1} + \\ & \sum_{j=1}^p \pi_1 \Delta CALO_{DEF_{t-j}} + \sum_{j=1}^p \pi_1 \Delta C_{GAS} - PC_{t-j} + \sum_{j=1}^p \pi_1 \Delta SWS_{t-j} + \sum_{j=1}^p \pi_1 \Delta LEXP_{t-j} + \sum_{j=1}^p \pi_1 \Delta POV_{t-j} \\ & + \mu_t \quad (Eqtn 5) \end{aligned}$$

A general error-correction representation of the equations above is formulated as follows:

$$\begin{aligned} \Delta Hwelfare = & \alpha_0 + \sum_{j=1}^p \pi_1 \Delta C_{GAS_{t-j}} + \sum_{j=1}^p \pi_1 \Delta CALO_{DEF_{t-j}} + \sum_{j=1}^p \pi_1 \Delta SWS_{t-j} + \sum_{j=1}^p \pi_1 \Delta LEXP_{t-j} \\ & + \sum_{j=1}^p \pi_1 \Delta POV_{t-j} + \delta_1 ECM_{t-j} + \mu_t \quad (Eqtn 6) \end{aligned}$$

## Results and Discussion

### Augmented Dickey-Fuller (ADF) Unit Roots Tests

The following table summarizes the results of the ADF/ PP unit root testing.

**Table 1: Augmented Dickey Fuller and Phillips-Perron Unit Root Test**

Variable		Level t-statistic value	1 <sup>st</sup> Difference t-statistic value	5% critical value	Order of Integration
Log(Hwfare)	ADF	-3.622137	****	-2.895109	I(0)
	P-P	-4.618824	****	-3.459950	I(0)
C-GASADF		**** -3.579335	-3.012363	I(1)	
	P-P	**** -3.579335	-3.012363	I(1)	



CALO-DEF	ADF	-5.980196	****	-3.004861	I(0)
	P-P	-5.368806	****	-3.004861	I(0)
LEXP	ADF	-3.755349	****	-3.012363	I(0)
	P-P	****	-3.774890	-2.893956	I(1)
SWS	ADF	****	-4.274614	-3.012363	I(1)
	P-P	****	-4.362737	-3.012363	I(1)
POV	ADF	****	-3.319148	-2.897223	I(1)
	P-P	-3.112550	****	-2.893589	I(0)

Source: Extracts from E-views 10

Above is the extract from the Augmented Dickey Fuller and Philips-Perron unit root tests. The unit root test verifies that the variables in the models are of order zero and one, that is, of mixed order of integration. Having confirmed that the variables: Households welfare (Hwfare), cooking gas (C\_GAS), calorie deficiency (CALO\_DEF), safe water/sanitation (SWS), life expectancy (LEXP) and poverty (POV) were of mixed order of integration, the study proceeded to estimate the food utilization-households model function using the Autoregressive Distributed Lags (ARDL) regression technique, by first examining the lag selection criterion.

### Lag Selection Criteria

Before delving into the complexities of the cointegration test, it is crucial to choose a suitable lag length. The Akaike Information Criterion in selecting an appropriate lag for this study. The maximum number of lags that could be taken in this study was determined to be six, utilizing Akaike Information Criterion (AIC), and this was selected for the estimation of a parsimonious model. The result is attached in the appendix page.

### Cointegration Testing Using ARDL Bounds

A cointegration test is one of the most certain ways to determine whether or not there is a long-run linkage between series in a model. Cointegration of two or more variables is defined economically as the existence of a long-run or equilibrium relationship between or among variables or series in the model (Gujarati, 2004). The cointegration results are summarized in Table 3.

**Table 2: ARDL Bounds Testing for Food Utilization and Households' Welfare in Nigeria**

Test Statistic	Value	K
F-Statistic	5.824056	5
<b>Critical Value Bounds</b>		
<i>Significance</i>	<i>I(0) Lower Bounds</i>	<i>I(1) Upper Bounds</i>
1%	3.41	4.68
5%	2.62**	3.79
10%	2.26	3.35



**Note:** \*\* signifies rejection of the null hypothesis at 5 per cent level of significance

**Source:** Author's Extract from E-views 10

Table 3 revealed that the estimated F-statistics for the ARDL Bounds Testing Wald Test revealed a value of 5.824056, which is greater than both the upper and lower bounds of the 95 percent critical value interval (2.32 – 3.5). This also necessitates the rejection of the null hypothesis that no long-run relationship exists between the variables, implying the existence of a unique long-run cointegrating relationship between food utilization and household welfare in Nigeria during the reference period.

#### **ARDL Longrun and Shortrun Estimates for Model 4:**

Food security is defined not only by the production and supply of food, but also by households having unrestricted and unfettered access to their food choices towards meeting their nutritional needs. This is critical, since leaving a healthy and productive life demands an adequate consumption of high-quality food in the recommended quantity and nutritional content. The food to be consumed passes through different processes before its final consumption (utilization) by the different households. While previous research in Nigeria has focused primarily on anthropometric indicators, total calorie intake, or the household dietary diversity score (HDDS), this study adds to the body of knowledge by examining factors influencing household food processing and utilization such as cooking gas (proxied by the official price of kerosene), calorie deficiency, the extent of poverty, life expectancy at birth and safe water and sanitation, These are all contingent upon households' actualization of their food potentials. Consequently, the model for this study is constructed and analyzed in order to provide an answer to the question "what significant influence does the determinants of food processing and utilization has on the welfare of Nigerian households?"

**Table 3: ARDL Regression Estimates**

<b>Dependent Variable: Hwfare</b>				
<b>Variable</b>	<b>Coefficient</b>	<b>Std Error</b>	<b>t-statistic</b>	<b>P-value</b>
<b>A: Longrun Estimates</b>				
CALO_DEF	6.975173	2.019375	3.454125	0.0012
C_GAS	0.162714	0.070748	2.299896	0.0026
LEXP	0.000000	0.000000	2.666918	0.0105
SWS	-0.000000	0.000000	-2.063998	0.0447
C	27.810698	0.344372	80.757693	0.0000
<b>B: Short-Run Estimates</b>				
D(CALO_DEF)	8.168808	1.361049	6.001845	0.0000
D(C_GAS)	0.215116	0.028675	7.501821	0.0000
D(LEXP)	0.000000	0.000000	5.028534	0.0000
D(SWS)	-0.000000	0.000000	-7.249977	0.0000
D(POV)	0.002485	0.000495	5.021635	0.0000
ECM(-1)	-0.092857	0.025683	-3.615454	0.0007

**Source:** Author's computation from E-views 10

Tables 3(A and B) show the findings of the longrun and shortrun estimates for the determinants of food processing, utilization and household welfare model for Nigeria. As a result of the statistically substantial positive link between calorie deficiency (Calo-Def) and household welfare shown in Table 3(A and B), each kilocalorie taken or consumed by households tends to make them more calorie deficient and thus food insecure. This finding

corroborates Fawole et al. (2015)'s assertion that the prevalence of malnutrition, food inadequacy, and the number of undernourished persons in Nigeria were increasing due to inadequate calorie consumption.

Additionally, as illustrated in Tables 3(A and B), (C-Gas) as proxied by kerosene (household fuel consumption) had a significant positive link with household food consumption patterns, as every naira increase in the cost of cooking energy resulted in a proportionate decrease in households' capacity to process their food, leading to a fall in their consumption patterns and hence their welfare during the study periods. This is especially true, given that the average Nigerian household's poor purchasing power has incapacitated them; hence they clearly lacked the financial muscle to continue purchasing kerosene fuel at exorbitant prices, thus their capacity for food processing is imperiled. This finding is further bolstered by the fact that the short run coefficient of poverty is positive; implying that as more households fall further into poverty, their ability to sustain food consumption is jeopardized. Thus, any exceptional and unjustified increase in the price of this critical cooking fuel comes with a detrimental effect on the welfare of households and their quest for food security. The finding is corroborated by Nwoko et al. (2016)'s assertion that fuel prices exert adverse effect on households' food security in Nigeria. Olugbire et al. (2016), and Emagbetere et al. (2016) also supported the aforementioned findings that increased income is required to keep up with rising cooking fuel costs.

Again in Table 3(A and B), the interaction between life expectancy (LEXP) and households' welfare showed her as a significant and positive predictor of households food use. To be precise, it was revealed that the more households' food security is imperiled, the likelihood of enjoying a decent living becomes a mirage, hence the potential for surviving beyond a certain age is jeopardized. Life expectancy in Nigeria has remained at a worrisome trend because many of the citizens are poor and as a result, experiences frequent food insecurity challenges, which in most part is the greatest trigger for malnutrition and deaths. The findings above is bolstered by Imonikebe (2010)'s study that, life expectancy in Nigeria has remained a worrisome trend because many of the citizens are poor and as a result experiences frequent food insecurity challenges, which in most part is the greatest trigger for malnutrition and deaths.

It was equally revealed in Table 3(A and B), that the interactions between households welfare and safe water / sanitation (SWS) had reported negative and significant relationship with food processing and utilization, which is in tandem with expectations. It was shown that lack of safe drinking water and sanitation impacted negatively on access to proper nutrition and food security. Safe drinking-water, sanitation and hygiene are crucial to human health and well-being. Furthermore, the short-run dynamics of the food processing / utilization show a significant and positive relationship between food utilization and poverty. Empirical evidence indicated that rising household poverty is a significant impediment to households' desire for increased food processing and use. This is not unconnected to government's incapacity to drive growth in the economy, both in the private and public sectors, leading to low economic growth with attendant high unemployment rates that further exacerbate the already high poverty incidence which continues to thwart every household's desire for guaranteed food security.

Finally, it was shown that when the food processing, utilizations and household welfare equations are disturbed, the slope coefficient of the error correction term (-0.092857) indicated the extent to which the equations readjust towards long-run equilibrium. Consequently, given the requisite system innovation, the error correction term revealed a 10 years and seven months period of convergence to equilibrium path. However, the achievement of these goals is conditional upon the effectiveness and efficiency of government policies in identifying appropriate solutions to Nigeria's food security crisis. The adjusted R-squared is 89 percent and the F-statistics are significant at the 1% level, indicating that the model is well fitted and explained. That is, the food utilization-corruption nexus model as captured or explained does indeed have a significant justification.

### **Conclusion and Policy Recommendations**

The main objective of this study was to determine the effect of food processing and utilization on the food security aspirations and welfare of Nigerian households. The study concluded that during the study periods, the welfare of several Nigerian households was jeopardized given the alarming poverty levels which impeded their access to vital ingredients such as cooking fuels, safe and clean water culminating in inadequate calorie consumption which severely undermined their aspirations for nutritious and healthy food. To this connection, this study concludes that Nigerian households were food insecure between 1999 and 2021. Consequently, it was recommended as follows:

- (i) To ameliorate or reduce the incidence of calorie deficiency among Nigerian households, it is recommended that households should reorder their eating habits by consuming foods high in fiber and making better drink choices
- (ii) Furthermore, the Nigerian government should work expeditiously and assiduously towards reviving the country's existing refineries in order to increase output and mitigate the current volatility in oil prices. These fluctuations have a detrimental effect on households' food security objectives, particularly in terms of transportation and distribution of food, as well as access to cooking energy, such as kerosene for cooking.
- (iii) Nigerian households can also improve on their diets or calorie intake by adding more fruits and vegetables to their eating plan.
- (iv) Both the government and households should ensure that safe drinking water and sanitation is taken very seriously to avoid the incidence of water borne disease such as diarrhea, typhoid fever and other water-related challenges. This they can do through sinking boreholes and investing in sensitization programmes for adequate enlightenment to the general public on the need to always consume safe water.
- (v) To address the current challenge of rising poverty, which has harmed households' expectations for food security, the government is advised to develop more effective poverty reduction policies that would mitigate the effect of poverty on Nigerian households.

## References

- Babatunde, R. O., Omotesho, O. A. & Sholotan, O.S. (2007). Socio-economic characteristics and food security status of farming households in Kwara State, North Central Nigeria. *Pakistan Journal of Nutrition*, 6(1), 49-58.
- Barret, C. B. (2002). Food security and food assistance programmes. In: Gardner, B. and Rauser, G. (eds) *Handbook of Agricultural Economics* Pp. 1-75, Department of Agriculture, Resource and Managerial Economics, Elsevier, Ithaca, Cornell University.
- FAO (2012). Committee on world food security: Coming to terms with terminology. Thirty-ninth session, Rome, Italy, 15-20 October. Retrieved from <http://www.fao.org/3/MD776E/MD776E.pdf>
- FAO, IFAD, UNICEF, WFP and WHO (2020). *The State of Food Security and Nutrition in the world 2020. Transforming food systems for affordable healthy diets for all*. Rome, FAO. <https://doi.org/10.4060/ca969en>. Accessed 9<sup>th</sup> June, 2021
- FAO (2000) Cited in Chapter 3, World food insecurity and malnutrition: Scope, trends, causes and consequences. Retrieved from <ftp://ftp.fao.org/docrep>.
- Fadare, O., Akerele, D., Mavrotas, G., & Ogunniyi, A. (2019). Effect of conflict and food price shocks on calorie intake and acute malnutrition in Nigeria: A micro-panel data analysis (No. 2229-2019-1929). Contributed Paper prepared for presentation at the 93rd Annual Conference of the Agricultural Economics Society, University of Warwick, England 15 - 17 April 2019.
- Fawole, W. O., Ilbasimis, E. & Ozkan, B. (2015.) Food insecurity in Africa in terms of causes effects and solutions: A case study of Nigeria. A paper presentation at the 2nd International Conference on Sustainable Agriculture and Environment held at the Selcuk University and Bahri Dagdas International Agricultural Research Institute Campus in the City of Konya, Turkey between September 30 and October 3, 2015.
- Food and Nutrition Technical Assistance (FANTA) Projects (2006) Cited in Chapter 3. World food insecurity and malnutrition: Scope, trends, causes and consequences. (Accessed from <ftp://ftp.fao.org/docrep> on 20th September, 2020
- Gujarati, D. N. & Porter, D. C. (2009). *Basic econometrics*, International Edition. New York: McGraw Hill/Irwin.
- Imonikebe, B. U. (2010) Constraints to food security in Nigeria and implications *African Research Review: An International Multi-Disciplinary Journal*, Ethiopia 4(4), 23-37.

- International Food Policy Research Institute (IFPRI) (2004). Assuring food and nutrition security in Africa by 2020: Prioritizing actions, strengthening actors, and facilitating partnerships. Proceedings of an All-Africa Conference. Kampala, Uganda, IFPRI, Washington, D.C.
- Kidane, W., Maetz, M. & Dardel, P. (2006). Food security and agricultural development in Sub-Saharan Africa. Building a case for more public support. *Policy Assistance Series II*. 43(2). Rome: FAO. Pp 104: DOI 10.1017/S0014479707005509
- Moratti, M. & Natalli, L. (2012) Measuring household welfare: Short vs long consumption modules. *Office of Research Working Paper 2012-No.4 / October 2012*.
- Muhammad-Lawal, A., Ibrahim, H. K., Oloyede, W. O., Belewu, K. Y. & Adesina, T. A. (2017). Assessment of dietary diversity and food calorie consumption among rural households in Kwara State, Nigeria. *Applied Tropical Agriculture*, 22(1), 134-141.
- Olarinde, L. O., Abass, A. B. Abdoulaye, T., Adepoju, A. A., Adio, M. O., Fanifosi, E. G. & Wasiu, A. (2020). The Influence of social networking on food security status of cassava farming households in Nigeria. In: *Sustainability*, 2, 5420. DOI:10.3390/su12135420 [www.mdpi.com/journal/sustainability](http://www.mdpi.com/journal/sustainability)
- Olugbire, O. O. & Aremu, F. (2016) Determinants of household cooking energy choice in Oyo State, Nigeria in [Russian Journal of Agricultural and Socio-Economic Sciences](#), 52(4), 28-36.
- Oni, O. A. & Fashogbon, A. E. (2013). Food poverty and livelihoods issues in rural Nigeria. *African Journal of Agricultural and Resource Economics, African Association of Agricultural Economists*, 8(2), 1-28.
- Onunka, C. N., Ihemezie, E. J., & Olumba, C. C. (2018). Household level analysis of food insecurity and coping strategies: Evidence from Enugu State, Nigeria. *Advances in Social Sciences Research Journal*, 5(6), 330-34.
- Owoo, N. S. (2021). Demographic considerations and food security in Nigeria. *Journal of Social Economics and Development*, 23, 128–167. Retrieved from <https://doi.org/10.1007/s40847-020-00116-y>
- Pesaran, M. H., Shin, Y. & Smith, R. J. (2001). Bound testing approaches to the analysis of level relationships. *Journal of Applied Econometrics*, 16, 289-326.
- Sen, A. (1981). Poverty and famines: An essay on entitlement and deprivation. Oxford University Press.
- United Nations Development Index (UNDI, 2013). *The rise of the south: Human progress in a diverse world*. Human Development Report 2013; UNDP publications. <https://www.undp.org/publications/human-development-report-2013>

Woolf, V. (2016). Woolf at the table: Good dinner, good talk @ <https://pshares.org/woolf-at-the-table-good-dinner-good-talk> accessed on 29th July, 2021

Worldwide Governance Indicators (2021). Retrieved from <http://databank.worldbank.org/data/source/worldwide-governance-indicators>.

World Governance Indicators (2021). World Governance Indicators (Aggregate Governance Indicators). Retrieved from [www.govindicators.org](http://www.govindicators.org).





## Effect of Analogy Teaching Strategy on Academic Performance of NCE II Biology Students' Misconceptions of Evolution Concept in Zaria

<sup>1</sup>Isah Aishat Yakubu, <sup>2</sup>Olaitan Aishat Salau & <sup>3</sup>Muhammad Ismail  
Department of Biology  
Federal College of Education, Zaria

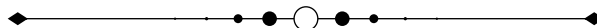

### **Abstract**

*This study seeks to investigate the effect of analogy teaching strategy on the academic performance of NCE II Biology students' misconceptions of evolution concepts in Zaria. In this study, a quasi-experimental research design was used. One hundred and twenty (120) NCE II Biology students were sampled from a population of 934 for the study. Two null hypotheses were formulated and tested. Evolution Performance Test (EPT) and Evolution Misconception Questionnaire (EMQ) were used as instruments for data collection. The collected data were analysed using means scores and standard deviation to answer the research questions and Mann-Whitney U-test statistical tools to test the stated hypotheses using Statistical Package for Social Sciences (SPSS, Version 22). The results showed that there is a significant difference in the academic performance of students exposed to teaching with analogy ( $p = 0.00$ ), and teaching with analogy has a positive effect on NCE II Biology students' academic performance. There is no significant difference in the mean misconception scores of NCE II Biology students taught using analogy teaching strategy and those taught using the lecture method ( $p = 0.83$ ). The researchers concluded by recommending that educational stakeholders should provide teaching and learning materials for teaching and learning evolution at NCE level using teaching-with-analogy, among others.*

**Keywords:** Analogy, Teaching strategy, Academic performance, Students' misconception, Evolution concept.

---

## **Introduction**

The emphasis on science education has undergone a considerable global shift over time. Children must be prepared to live in a society where science and technology are increasingly dominant, so scientific education is a crucial component of fundamental education (International Council for Science, 2012). The science education field focuses on disseminating scientific knowledge and methods to people who aren't typically considered members of the scientific community. Through science education, the typical teacher-centred classroom lecture should be able to be transformed into a discovery and problem-solving atmosphere. This encourages creativity and innovation. To accomplish this, the students must actively engage in problem-solving and issue-identification activities (Renner, Stafford, & Ragan, 2013). Shaibu (2013) claims that science is an advanced human endeavour that produces a collection of generalisations (scientific laws and theories) that are applied to explain the observed behaviour of the world or a component part of it and that can also be anticipated. That is, the questions that researchers consider and delve into deeply enough to produce knowledge that is made public. Schafar (2013) reiterates the definition of science as the empirical study of processes using the scientific method. Science has a tendency to put theories to the test in an endeavour to learn the truth. Asking questions is only one aspect of science. The focus of science education is biology. According to Ziegler and Montplaisir (2014), offering students a range of options can help them understand different concepts, theories, and guiding principles when they are learning biology. Among other subjects, biology is a prerequisite for the study of medicine, agriculture, and pharmacy. Chew (2014) said that biological concepts can occasionally be tough, particularly when describing oblique or esoteric notions that are difficult to fully comprehend the first time. A few of the biological areas that students found difficult include genetics, evolution, ecology, and physiology (WAEC Examination's Report, 2010; Oyedokun, 2012). Additionally, research has shown that many biological concepts, such as evolution, contain principles that are difficult for biology students to understand. A typical biology text will include flowery language that some students find trivial and others find unnecessarily technical. Many students are also thought to have false views about the concepts of evolution based on how they were taught biology in school (Usman, 2008). One learner factor that impairs meaningful learning in biology generally is the students' inaccurate grasp of the concepts of evolution. (Hanisch & Eirdosh, 2020; Karatas, 2019). This false perception may be caused by teachers' inability to clearly explain scientific topics to students, according to Akinsola and Igwe (2012). Maduabum (2014) discovered that the intricacy of several of the subject's subjects was the primary source of the problems with biology instruction that led to students' poor performance.

The most common uses of analogies in education are to help students connect new material to their existing knowledge base and to help them comprehend new material in terms of previously learned material (Venville & Treagust, 2017). Analogies are essential for understanding and developing cognitive ideas and concepts. It is an effective tool for teaching and learning. Using similarities to the topic at hand, analogies are a way of finding and expressing fuzzy ideas or information (Sezer & Karatas, 2022). By helping students increase their knowledge and critically analyse what they have learned, or by helping them solve issues by drawing comparisons to existing knowledge, analogies are vital for enabling and fostering learning (Akaygun et al., 2018). Analogies can also be encouraging when learning anything worthwhile. Analogies can boost a student's interest in and involvement in a subject. Students are three to four times more likely to pay attention to an analogy's familiar language than they

are to a scientific concept's unfamiliar language, claims Cain (2016). Students who struggle with or feel uneasy using scientific terminology can nonetheless demonstrate their understanding of and interest in a subject by using the familiar language of an analogy. Both of these motivating elements may be affected by an analogy. Students' interest in a subject and opinions about their ability to understand or overcome a particular issue both contribute to motivation. Analogies encourage students to absorb new material by linking it to their personal experiences in the actual world (Alk & Kaya, 2022). Students' confidence in their capacity to solve difficulties can also be boosted when the new problem or new knowledge is tied via analogy to a problem or piece of information that they have already solved or understood (Sturm & Bohndick, 2021). Finally, as was already said, parallels can support conceptual development by helping students challenge preconceived notions. In a perfect world, analogies would help students spot defects in preexisting concepts, reject those conceptions, and adopt fresh conceptions that are in line with those accepted by the scientific community. Analogies can assist in making unfamiliar notions clear and initially convincing by contrasting them with well-known facts. If students can assimilate new material in terms of their past knowledge, they are more likely to comprehend it, communicate it in their own words, and comprehend how the new information might be consistent with reality—all requirements for conceptual change (Gurevich, 2021).

### **Statement of the Problem**

Numerous studies (Archila et al., 2023; Beggrow & Sbeglia, 2019; Yates & Marek, 2015) have demonstrated that students enter college-level biological anthropology and other biology courses with misconceptions about the nature of science and evolutionary theory that may prevent them from understanding the scientific explanations given in class. These incorrect ideas could be based on personal experience, regional slang, religion, myth, or ones that one has learned, acquired, or fabricated. As a result, misconceptions among students are usually complex and deeply rooted. As a result, they "are robust enough to have survived schooling" (Palmer, 2009) and impede students from understanding science topics in college courses. Evolution, defined more broadly as cumulative change in the natural world over time, is a related fundamental and unifying concept in the natural sciences as a whole. However, difficulties with instructional approaches and social disputes have plagued the teaching and learning of evolution.

According to Salam (2010) and Olatoye (2012), a lot of researchers have been very concerned about the issue of student misunderstanding and poor performance at the NCE level in evolution courses. According to Mupa and Chinooneka (2015), the difficulty of evolution's principles and the teacher's failure to adopt an effective teaching strategy, such as activity-based or analogous instruction, were to blame for the students' poor performance in biology. The teacher can effectively address this problem by making a link between the students' prior knowledge and the unfamiliar concepts. Analogies can be used to draw this connection because they help pupils easily assimilate new information, especially complicated topics, by relating it to what they already know. As a result, using analogies to teach about evolution may be essential. Specifically, this study seeks to investigate the effectiveness of analogy strategy on students' misconceptions and performance in evolution concept among NCE II Biology students in Federal College of Education, Zaria.

### **Objectives of the Study**

The study's objectives are as follows:

1. Investigate the effects of teaching with analogy on academic performance of NCE II Biology students in evolution concepts;
2. Investigate the effect of teaching with analogy on student's misconception on evolution concept

### **Research Questions**

The study has these research questions:

- i. What is the effect of teaching with analogy on academic performance of NCE II Biology students taught evolution concepts?
- ii. What is the effect of teaching with analogy on students' misconception on evolution concept?

### **Null Hypotheses**

H<sub>01</sub>: The mean scores of students who were taught evolution concepts using the analogy teaching strategy and those who were taught using the lecture method did not differ significantly.

H<sub>02</sub>: There is no significant difference in the effect of teaching with analogy on students' misconception on evolution concept.

### **Methodology**

This study used a quasi-experimental design that included a pre-test, post-test, and post-post-test experimental control group. All N.C.E. II Biology students at the Federal College of Education in Zaria who had registered for the 2020–2021 session made up the study's total population of 934 participants. A total of 120 NCE II Biology students from FCE, Zaria, made up the study's sample. The sample was drawn using a simple random sampling technique involving a ballot system. The Evolution Performance Test (EPT) and the Evolution Misconception Questionnaire (EMQ) were developed as instruments for the study. The instruments were validated for clarity of language, to measure the concept of evolution level, and for appropriateness by two (2) experts in the field of research with a minimum of M.Sc. Ed. The researchers conducted the 4 week, one hour per week, lesson plan-based teaching of the concepts. Teaching with Analogy (TWA) was the method that was employed to teach the experimental group. The researchers used the lecture method to impart identical ideas to the control group. During the utilisation of one (1) hour every week for four (4) weeks, prior to the start of the lesson, the subjects were given the pre-test. The subject matter was defined, followed by an explanation, and key points were noted on the chalkboard as the lesson was presented. For extra information, the respondents were directed to the appropriate biology text books. Both the experimental and control groups underwent a post-test using EPT after two weeks of teaching. A post-post-test (EMQ) was given two weeks later. The response of the subjects to Evolution Performance Test and Evolution Misconception Questions were scored using the marking scheme. Mann-Whitney U-test was used to analyse null hypothesis 2, while mean rank scores and mean gain were used to descriptively analyse research question 2. The mean scores that were obtained from EPT and EMQ were used for testing the hypotheses. The hypotheses were analysed using t-test via SPSS (version 22) as statistical tools for data analysis. Mann-Whitney U-test was used to analyse null hypothesis two, while mean rank scores and mean gain was used to descriptively analyse research question two.

## Results

**Research Question One:** What is the effect of teaching with analogy on academic performance of NCE II Biology students taught using evolution concepts. In order to answer research question one, the post test scores for NCE II Biology students taught using evolution concepts and those taught using lecture method was used. This was analyzed descriptively using mean and the mean difference as presented in Table 1.

**Table 1: Mean and Standard Deviation for Effect of Teaching with Analogy on Academic Performance of NCE II Biology Students**

	Variables	N	$\bar{X}$	S.D	Mean Difference
Posttest	Experimental Group	60	16.38	2.73	3.71
	Control Group	60	12.67	1.59	

Table 1 showed that there is a difference in mean between students taught using analogy and those taught using the lecture method, with a mean difference of 3.71 in favour of those taught using analogy. From the table, students in the experimental group outperformed those in the control group with a mean of 16.38 and 12.67, respectively. This implies that teaching with analogy strategies has a positive impact on students' academic performance. However, to find out how significant the difference in the mean scores between the two groups is, the data were subjected to a t-test.

**Research Question Two:** What is the effect of teaching with analogy on students' misconception of evolution concepts?

Descriptive statistics of Mean ranks mean gain/loss were used to answer the research question. The results of the analysis are presented in Table 2.

**Table 2: Results of Mean Rank, and Mean Rank Differences for NCE II Biology Students before and after exposure to Teaching with Analogy Strategy**

Group	N	$\bar{X}$ Rank	Sum of Ranks	Mean Rank Gain
Pre Misconception	60	59.83	3590.0	1.34
Post Misconception	60	61.17	2670.0	

Results in Table 2 revealed the difference in misconceptions among NCE II biology students before and after exposure to treatment. The table shows the mean misconception scores for students before and after exposure to teaching with analogy ( $M = 59.83$  and  $61.17$ ), respectively. That is, the mean misconception scores for students before and after treatment were different. The difference between the pretest and posttest mean rank differences of the students was 1.34 in favour of those exposed to teaching with analogy. This is an indication that teaching with analogy affects students' misconceptions of evolution concept positively. To determine whether the mean rank difference is significant or not, Hypothesis 2 was tested.



## Hypotheses Testing

**Null Hypotheses One:** There is no significant difference in the mean scores of students taught evolution concepts using analogy teaching strategy and those taught using lecture method.

To test null hypothesis one, the performance posttest scores of students taught using analogy teaching strategy and those taught using lecture method were subjected to t-test. The result is shown in Table 3.

**Table 3: Summary of t-test Analysis for Difference in Performance of Students taught Evolution Concepts in the Experimental and Control Groups**

Group	N	Mean	Std. Deviation	df	t-cal	t-crit	p-value	Remark
Experimental	60	16.38	2.73	118	9.12	1.98	0.00	Sig.
Control	60	12.67	1.60					

Significant at  $p \leq 0.05$

Table 3 shows the results of an independent t-test analysis showing that significant differences exist in the performance of evolution concepts between students exposed to teaching with analogy and those exposed to lecture methods. The reason is that the calculated p-value of 0.00 is less than the 0.05 level of significance. Their calculated mean performances are 16.38 and 12.67 for students exposed to teaching with analogy and those exposed to lecture method, respectively, with a mean difference of 3.71 in favour of those exposed to teaching with analogy. This implies that students exposed to teaching with analogy significantly performed better in evolution concepts than their counterparts taught with the lecture method. Therefore, the null hypothesis, which states that there is no significant difference in the mean scores of students taught evolution concepts using an analogy teaching strategy and those taught using the lecture method, is hereby rejected.

**Null Hypothesis Two:** There is no significant difference in the effect of teaching with analogy on students' misconception of evolution concepts.

The null hypothesis was tested using the Mann-Whitney U test at  $p \leq 0.05$  level of significance. Table 4 presents the findings of the analyses.

**Table 4: Results for Mann-Whitney U Test on Students' Misconception of Evolution Concept**

Group	N	Mean Rank	Sum of Ranks	Z	U-value	P	Decision
Pre-misconception	60	59.83	3590.0	-0.211	1760.0	0.83	Not Significant
Post-misconception	60	61.17	3670.0				

The results of the Mann-Whitney U-test are shown in Table 4, and they indicate that there is no statistically significant difference in the mean misconception scores of NCE II Biology students who were taught via analogy. ( $U=1760.0$ ,  $p = 0.83$ , which demonstrated that there is no statistically significant difference in the mean misconception scores for NCE II Biology



students taught via analogy, supports the conclusion. Since the p value of 0.83 is greater than the 0.05 level of significance, the null hypothesis, which claims that there is no significant difference in the effect of teaching with analogies on students' misconceptions of evolution concepts, is maintained.

### **Discussion of Results**

The outcome of testing hypothesis one revealed a significant difference between students who received analogy-based teaching and those who received lecture-based teaching in their understanding of evolution principles ( $p = 0.00$ ). The academic performance of NCE II Biology students is improved by teaching through analogies. The outcomes supported the findings of Beggrow and Sbeglia (2019), Akaygun et al. (2018), and Sezer and Karatas (2022) that analogy teaching strategies are tools for improving student performance.

According to Hypothesis 2, there is no discernible difference in the impact of analogy-based instruction on students' misconceptions of the idea of evolution. According to the results, there is a significant difference between students who were taught evolution principles through analogies and those who were taught using the lecture technique ( $p = 0.00$ ). When evolution ideas are taught using an analogy-based approach, NCE II Biology students perform better than when the lecture method is used. This demonstrates how the teaching-with-analogy method employed helped the experimental group students perform better and learn the concept of evolution more thoroughly. This is because the method made it easier for students to assimilate new information, particularly abstract concepts, into their existing knowledge, leading to a better scientific grasp of the topic. These help with memory retention, which boosts kids' performance. This is consistent with research by Owolabi (2007) and Karatas (2019), who found that teaching via analogies helps dispel students' scepticism about specific facts pertaining to scientific ideas and improves concept performance when compared to the lecture technique. In their study, Ziegler & Montplaisir (2014) also showed how teaching with analogies might help students understand difficult topics by drawing on previous knowledge and experiences to motivate them to acquire new material. The results of this study suggest that teaching evolution topics through analogy can improve NCE II biology students' academic performance.

### **Conclusion**

When students at the NCE level are taught evolution topics using analogy, they learn these concepts more effectively. At the NCE level, students in the subject area demonstrated significantly improved performance when taught evolution ideas through the lens of teaching with analogy. When it came to understanding evolution ideas at the NCE level, male students who were taught with analogies had a better degree of achievement than female students who were taught with the same method. According to the results of this research, the use of analogies in the classroom has the potential to improve the academic performance of NCE students in the area of evolution concepts.

### **Recommendations**

From the findings of this study, the following recommendations are made:

1. Educational stakeholders should provide teaching and learning materials for teaching/learning evolution at NCE level using teaching-with-analogy.
2. Teachers should choose teaching with analogies that students are familiar with since these analogies are motivating for students, prevent time wastage, and are simple for

- teachers to employ.
3. Teaching-with-Biology instructors should promote the usage of analogies while instructing NCE biology students on the concepts of evolution.
  4. Since teaching with analogies is a relatively new method with many steps to successful implementation, it should be included in teacher education curricula and taught alongside other teaching techniques.

## References

- Akaygun, S., Brown, C., Karatas, F. O., Supasorn, S., & Yaseen, Z. (2018). Teaching chemistry with analogies around the world: Views of teachers from four countries. In *International Perspectives on Chemistry Education Research and Practice* (pp. 129-146). American Chemical Society.
- Akinsola, M. K. & Igwe, I. O. (2012). The relative effect of meta-cognitive strategy of framing on student's achievements in selected difficult chemistry concepts. *The Journal of Science Teachers Association of Nigeria*, 37(1 and 2), 20-28.
- Archila, P. A., Restrepo, S., & Truscott de, M. (2023). STEM and non-stem misconceptions about evolution: Findings from 5 Years of Data. *Sci & Educ.* <https://doi.org/10.1007/s11191-023-00428-5>
- Beggrow, E. P., & Sbeglia, G. C. (2019). Do disciplinary contexts impact the learning of evolution? Assessing knowledge and misconceptions in anthropology and biology students. *Evo Edu Outreach* 12(1). <https://doi.org/10.1186/s12052-018-0094-6>
- Cain, W. L. (2016). Science concept achievement using rich, best-practice analogies (Doctoral dissertation). Capella University.
- Çalık, M., & Kaya, E. (2022). Examining analogies in science and technology textbooks and science and technology curriculum. *Elementary Education Online*, 11(4).
- Chew, F. T. (2014). Use of analogies to teach general biology to non-biology majors. Retrieved from <http://www.edt.nus.edu.sg/link/mar2004/tm3.htm>. Retrieval 28/03/2016
- Gurevich, G. (2021). Analogy as prerequisite for understanding: A hypothesis and its implications. Retrieved from <https://ssrn.com/abstract=3838563> or <http://dx.doi.org/10.2139/ssrn.3838563>
- Hanisch, S., & Eirdosh, D. (2020). Educational potential of teaching evolution as an interdisciplinary science. *Evo Edu Outreach* 13, 25. Retrieved from <https://doi.org/10.1186/s12052-020-00138-4>
- International Council for Science (2012). ICSU series on science for sustainable development No.5: Science Education and capacity building for sustainable development. Retrieved from <http://www.icu.org/library/WSSD-Rep/Vol15.pdf>

- Karatas, A. (2019). Opinions of pre-service teachers about evolution. *Journal of Education and Training Studies*, 7(8), 1-12.
- Mupa, P. & Chinooneka, I. T. (2015). Factors contributing to ineffective teaching and learning in primary schools: Why are schools in decadence? *Journal of Education and Practice*, 6(19), 125-132.
- Olatoye, R. A. (2012). A causal model of school factors as determinants of science achievement in Lagos State Secondary Schools. An Unpublished PhD Dissertation. University of Ibadan, Ibadan.
- Owolabi, T. (2007). The use of analogy as vehicle for achieving effective physics delivery in some selected senior secondary schools in Lagos. Proceeding of Science Teachers Association of Nigeria National Conference 2007.
- Oyedokun, M. R. (2012). Identification of difficult topics in the senior secondary school certificate biology syllabus as perceived by students. *The Nigerian Teacher Today*, 10(1), 110-120.
- Palmer, D. H. (2009). Exploring the link between students. Scientific and nonscientific conceptions. *Science Education*, 83, 639-653.
- Renner, S. & Ragan, W. (2013). *Teaching science in the elementary school*. Harper & Row.
- Salim, B. (2010). JAMB results. The Daily Times July 27, P. 1
- Sezer, K. & Karatas, O. F. (2022). Research trends about analogy studies in science education: A descriptive content analysis. *Journal of Science Learning*, 5(2), 217-225.
- Shaibu, A. A. M. (2013). *Foundation of science education*. University Lecture, AB.U, Zaria.
- Sturm, N. & Bohndick, C. (2021). The influence of attitudes and beliefs on the problem-solving performance. *Sec. Educational Psychology*, 6, 20-45.
- Venville, G. J. & Treagust, D. F. (2017). Analogies in biology education: A contentious issue. *The American Biology Teacher*, 59, 282-287.
- West African Examination Council (WAEC), (2010). Chief examiners' report.
- Yates, T. & Marek, E. (2015) A Study Identifying Biological Evolution-Related Misconceptions Held by Prebiology High School Students. *Creative Education*, 6, 811-834. doi: [10.4236/ce.2015.68085](https://doi.org/10.4236/ce.2015.68085).
- Ziegler, B., & Montplaisir, L. (2014). Student perceived and determined knowledge of biology concepts in an upper-level biology course. *CBE Life Sciences Education*, 13(2), 322–330. <https://doi.org/10.1187/cbe.13-09-0175>



## Problematizing Statement of Research Problem in a Research Topic

<sup>1</sup>Awen, Benjamin Iorsue and <sup>2</sup>Jimoh, Ihiovi Ojo

<sup>1</sup>Department of Business Education, Federal College of Education, Zaria

<sup>2</sup>Department of Local Government and Development Studies,  
Faculty of Administration, Ahmadu Bello University, Zaria

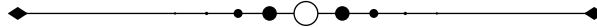

### *Abstract*

*Identification of statement of research problem has been a major issue troubling researcher and this was promised on the poor reading habit and understanding what exactly the study set out to solve. Therefore, this study was designed to guide researcher on areas where they can easily identify their research problem. The conceptual paper was guided from the evidenced documented from previous studies and other library materials. The study identified the following areas as a veritable source of statement of problem identification in a research. Such areas include: scope, location, methodology, literature review and significance or justification of the previous work. Other vital areas to consider are policy documents, observation, and situational analysis, deductions from theory, interviewing practitioners, personal experience and interdisciplinary perspectives. The study therefore recommends that a research topic should be compelling, researchable and it should support multiple perspectives.*

**Keywords:** *Research, Problem, Statement, Conceptualization and Identification*

---

### **Introduction**

A research problem is a definite or clear expression [statement] about an area of concern, a condition to be improved upon, a difficulty to be eliminated, or a troubling question that exists in scholarly literature, in theory, or within existing practice that points to a need for meaningful understanding and deliberate investigation. A research problem does not state how to do something, offer a vague or broad proposition, or present a value question. The common challenge faced by researcher is the identification of research problem of their study. How to create problem out of research topic remains a huge task that so many studies conduct failed to

solve or address any specific issue. Creating a research problem demands an extensive reading around the study domain and ability to comprehend the desire objective that the study set out to achieve also play significant role in this direction. In social science research which does not involve any laboratory scientific testing of reagents or chemical reaction, one can't blame researcher in absolute term if they cannot identified the needed problem statement that will address their aims and objective of the study. Overtimes, evidence has shown that poor problem statement have led some many research works to mere classwork and subsequently result in fruitless efforts (Daellenbach, McNickle & Dye, 2012). The primary reason, according to Laudon and Laudon (2009) for this inability to formulated researchable problem statement is not farfetched. For instance, before set out to conduct a research study, research interest must be very strong. Starting research with already bias mind will certainly rob one the idea to problematize the research problem. It is interesting to know that statement of research problem is central and critical to the successful completion of the research work. Many studies were abandoned when the researcher was already halfway through simply because of poor problem statement. Similarly, some concluded ones failed to added or contribute to knowledge because there was no identifiable research problem statement in the study.

Research is a logical process that one step leads to another. It is a procedural exercise that needs to be understood and follow logically in other to solve the desire problem. It therefore means that every stage of research is quite important. Cavana, Delahaye and Sekaran (2001), stated that when problem statement is stated properly, it gives the opportunity to formulate good research questions which will translate into research objective and research hypotheses accordingly. A good statement of research problem therefore serves as a feeder to the above mention segments of the research. It is when a researcher was able to situate its research objective within the domain of its study that a good outcome of the research can be expected.

Today, we find out the bunch of research works lies dusty in the corner of offices without making use of despite all the efforts put in writing these projects (Checkland, 2000). Imaging the resources, such as time, money and energy that has been sunk into it and to end up just like a mere toilet paper. Therefore, this study was conceived to address the problem statement in research in order to reduce if not eliminating the phobia that normally engulf the mind of researcher in problematize the statement of research problem. Hence, this study tend pointing to the critical areas researcher can establish their research problem without condemning the previous work or authors. It is pertinent to state that in an effort to create problem of the study, one can do this without attacking the previous authors' person. All that needed is just an art of reviewing previous work while developing an attitude of constructive criticism. Reviewing previous studies objectively will place you on the good pedestal to develop statement of the research problem without character assassination. Among the areas statement of research problem can be couch out are: time frame, location, methodology, findings and conclusion. Also, for qualitative research, issues can be raised on the policy documents, observations and situation analysis. This study will take a look at them one after the other.

### **Conceptual Review**

There are many different methods regarding problem defining process in the literature. They include referring to the literature, contemporary practices, personal experiences and applying to other disciplines (Alter & Dennis, 2002). Among others, identifying research gaps is the most outstanding method (Alvesson & Sandberg, 2011). Such studies are focused on three different cases. Firstly, as controversial items are identified in the literature, studies are carried



out to enlighten these items (Kwiatkowski & Silverman, 1998). Second, complementary studies are carried out in relation with previous studies in the literature (Tsui, Zhao, & Abrahamson, 2007). Third, studies are carried out to identify and close the practical gaps in cases where theoretical studies are completed but not implemented yet (McMillan & Schumacher, 2010). Researchers think in relation with defining the research problem that critical thinking is needed to find out contemporary and new issues under circumstances (Maddux, 2003). This suggestion could guide researchers engaged in educational technology, which is multidisciplinary and affected from technological improvements. The literature presents many studies on describing research trends in educational technology (Alper & Gülbahar, 2009; Göktaş et al., 2012).

### **Methodology**

The conceptual paper relied majorly on documented evidence based on many previous works. It is a library research that draw source material from evidence already documented in the literature couple with personal observation from the seminar, conference and students' project supervised.

### **Discussion of Results**

The research problem is the heart of a study. It is a clear, definite statement of the area of concern or investigation and is backed by evidence (Bryman, 2007). It drives the research questions and processes and provides the framework for understanding the research findings. To begin, you will need to know where to look for your research problem and how to evaluate when a research problem for success. Scientific research usually starts with having a problem, willingness to solve a problem or interest in a topic. Thus, each study starts with a research problem and ends with a report (Dunne, Pryor, & Yates, 2005). A research problem can be identified with different ways. They include researcher's daily life experience (Maddux, 2003), problems faced in implementation, need for testing theories (Tomul, 2009) and recommendation raised by previous studies (Chow & Harrison, 2002; Johnson & Christensen, 2004). Besides interesting, researchable, manageable and fruitful topics, researcher's having sufficient preliminary information and skills about the topic and availability of related data affect definition of research topic (Brewerton & Millward, 2001; Daymon & Holloway, 2002; Polonsky & Waller, 2005). Additionally, discussion of potential research topics in scientific events plays an important role in defining the problem to be studied (Kwiatkowski & Silverman, 1998; Maddux, 2003).

After deciding on the research problem, the problem must be narrowed down and research questions must be written (Anderson, 1998). Many researchers point out that defining the problem bears critical importance for the whole research process (Bryman, 2007). In this point, it is important to distinguish between the research topic and research problem. Research topics can be arising from researchers' personal experiences and knowledge gained by the different studies on the other hand research problem defines the specialty about the topic (Campbell, Daft, & Hulin, 1982 as cited in Bradley, 2001). Hence research problems contribute the development of interesting and significant theories or testing theories (Alvesson & Sandberg, 2011). Also, they directly influence the connection with the literature and the research methodology (Bryman, 2007). The identification of a problem in study can be challenging, not because there's a lack of issues that could be investigated, but due to the challenge of formulating an academically relevant and researchable problem which is unique and does not simply duplicate the work of others. To facilitate how you might select a problem



from which to build a research study, the following areas need to be considered:

### **Deductions from Theory**

This relates to deductions made from social philosophy or generalizations embodied in life and in society that the researcher is familiar with. These deductions from human behavior are then placed within an empirical frame of reference through research. From a theory, the researcher can formulate a research problem or hypothesis stating the expected findings in certain empirical situations. The research asks the question: "What relationship between variables will be observed if theory aptly summarizes the state of affairs?" One can then design and carry out a systematic investigation to assess whether empirical data confirm or reject the hypothesis, and hence, the theory.

### **Interdisciplinary Perspectives**

Identifying a problem that forms the basis for a research study can come from academic movements and scholarship originating in disciplines outside of your primary area of study. This can be an intellectually stimulating exercise. A review of pertinent literature should include examining research from related disciplines that can reveal new avenues of exploration and analysis. An interdisciplinary approach to selecting a research problem offers an opportunity to construct a more comprehensive understanding of a very complex issue that any single discipline may be able to provide.

### **Interviewing Practitioners**

The identification of research problems about particular topics can arise from formal interviews or informal discussions with practitioners who provide insight into new directions for future research and how to make research findings more relevant to practice. Discussions with experts in the field, such as, teachers, social workers, health care providers, lawyers, business leaders, etc., offers the chance to identify practical, "real world" problems that may be understudied or ignored within academic circles. This approach also provides some practical knowledge which may help in the process of designing and conducting your study.

### **Personal Experience**

Don't undervalue your everyday experiences or encounters as worthwhile problems for investigation. Think critically about your own experiences and/or frustrations with an issue facing society, your community, your neighborhood, your family, or your personal life. This can be derived, for example, from deliberate observations of certain relationships for which there is no clear explanation or witnessing an event that appears harmful to a person or group or that is out of the ordinary.

### **Relevant Literature**

The selection of a research problem can be derived from a thorough review of pertinent research associated with your overall area of interest. This may reveal where gaps exist in understanding a topic or where an issue has been understudied. Research may be conducted to: 1) fill such gaps in knowledge; 2) evaluate if the methodologies employed in prior studies can be adapted to solve other problems; or, 3) determine if a similar study could be conducted in a different subject area or applied in a different context or to different study sample (i.e., different setting or different group of people). Also, authors frequently conclude their studies by noting implications for further research; read the conclusion of pertinent studies because

statements about further research can be a valuable source for identifying new problems to investigate. The fact that a researcher has identified a topic worthy of further exploration validates the fact it is worth pursuing.

### **Time Frame**

The time frame of previous research gives ample opportunity to create a statement of problem. It is interesting to note that there is nothing new absolutely that the research will bring in entirety. Therefore, taking previous and evaluate the scope of time it covers provide room for further study. For instance, if the scope of study covers 2001 – 2010, similar study can be reexamined for 2011 – 2020. In between the years the previous study was done, so many events might have happened which in no doubt render whatever findings at that time useless. The gap in the scope would be filled by the present study. This also provides an opportunity to re-evaluate the findings of the previous study, if there is no change and as such the study could stand the test to time. This also provides rooms for consistence given the facts that the present study adopted the same procedural approach. As we do know, change is the only constant factor, therefore, there is bound to arrive at different findings and conclusion because of the time frame variances. When this happened, the consequence is the value addition or contribution to knowledge because gap created via the time frame has been filled.

### **Location**

Study location provides a viable way to formulate statement of the problem because of different geographical factors. For instance, the study conducted in Brazil may have different findings and conclusion when such similar study was undertaken in Nigeria or USA. This is true because of different environmental and geographical location that has influence on the outcome of the study. Similarly, the continental location also dictates to a large extent the outcome of research study from various studies. Therefore, the setting of any study provides an avenue for researchers situate their research problem and ultimately, the findings from this study can't be the same.

### **Methodology**

Methodology is the road map that the researcher follows to achieve the desire objective while providing solution to the problem stated. Once a faulty methodology is adopted, the study may not likely address the aim of the study. There is always issue in using different methodology for the same study and consequently resulted to different findings. This inconsistency in the methodology have equally greeted inconclusive and inconsistency findings. The aspect can capitalize as a loophole to punch the previous work and does, generate problem statement.

### **Findings**

From the previous studies, one can evaluates the findings from similar studies and compare the outcomes. It may likely possible that there will be variation in the findings or there is likelihood of inconsistency in the previous work. This will present a better opportunity for the new researcher to establish his/her own problem base on the gap noticed.

### **Significance**

The level of contribution of the same study may differ in scope and content. For instance, one may look at whether the existing study has made practical, theoretical or empirical

contribution. Where any of this could not be established, then there exists a gap that needs to be filled.

### **Policy Documents**

In government research or non-governmental research, there usually a policy document that there establishment or operation, this document provide a fertile ground to develop statement of problem.

### **Observation**

One could notice an undesirable prevailing situation on ground that needs to be found out what must warranted such situation. It will be pertinent to state that situation must have negative or positive consequence on the subject and there is need to get it addressed via extensive research and possible recommendation. For instance, the emergency of covid-19 pandemic that cause damage to the whole world need to be research in order to safeguard its reoccurrence.

### **Conclusion and Recommendations**

This review was to draw the attention of researchers on how to identify research problem in a particular topic. To establish research topic, has possess a heavy task to researcher and this has resulted in having the bulk of research work as a wasted efforts. Therefore, this study is to enhance the researchers' knowledge on how to identify research statement of their study. In conclusion, a good problem statement begins by introducing the broad area in which your research is centered, gradually leading the reader to the more specific issues you are investigating. Therefore, the study recommends that, the statement need not be lengthy, but a good research problem should incorporate the following features:

The problem chosen should be one that motivates you to address it but simple curiosity is not a good enough reason to pursue a research study because this does not indicate significance. The problem that you choose to explore must be important to you, but it must also be viewed as important by your readers and to the larger academic and/or social community that could be impacted by the results of your study.

The problem must be phrased in a way that avoids dichotomies and instead supports the generation and exploration of multiple perspectives. A general rule of thumb in the social sciences is that a good research problem is one that would generate a variety of viewpoints from a composite audience made up of reasonable people. This isn't a real word but it represents an important aspect of creating a good research statement. It seems a bit obvious, but you don't want to find yourself in the midst of investigating a complex research project and realize that you don't have enough prior research to draw from for your analysis. There's nothing inherently wrong with original research, but you must choose research problems that can be supported, in some way, by the resources available to you. If you are not sure if something is researchable, don't assume that it isn't if you don't find information right away.

## References

- Alper, A. & Gülbahar, Y. (2009). Trends and issues in educational technologies: A review of recent research in TOJET. *The Turkish Online Journal of Educational Technology*, 8(2), 124-135.
- Alvesson, M. & Jörgen, S. (2011). Generating research questions through problematization. *Academy of Management Review*, 36, 247-271.
- Anderson, G. J. (1998). *Fundamentals of educational research* (2nd ed.). London: Routledge.
- Bradley, D. B. (2001). Developing research questions through grant proposal development. *Educational Gerontology*, 27(7), 569-581.
- Brewerton, P. & Millward, L. (2001). *Organizational research methods: A guide for students and researchers*. London: Sage.
- Bryman, A. (2007). Barriers to integrating quantitative and qualitative research. *Journal of Mixed Methods Research*, 1(1), 8-22.
- Bryman, A. (2007). The research question in social research: What is its role? *International Journal of Social Research Methodology*, 10(1), 5-20.
- Cavana, R. Y., Delahaye, B. L. & Sekaran, U. (2001). *Applied business research: Qualitative & quantitative method*.
- Checkland, P. (2000). Soft systems methodology: A thirty year retrospective. *Systems Research and Behavioral Science*, 17, S11- S58.
- Chow, C. W. & Harrison, P. D. (2002). Identifying meaningful and significant topics for research and publication: a sharing of experiences and insights by 'influential' accounting authors. *Journal of Accounting Education*, 20(3), 183-203.
- Daellenbach, H., McNickle, D. & Dye, S. (2012). *Management science: Decision-making through systems thinking*. Palgrave Macmillan.
- Daymon, C. & Holloway, I. (2002). *Qualitative research methods in public relations and marketing communications*. Florence: Routledge.
- Dunne, M., Pryor, J. & Yates, P. (2005). *Becoming a researcher: A research companion for the social sciences*. Maidenhead: Open University Press.
- Göktaş, Y., Küçük, S., Aydemir, M., Telli, E., Arpacık, Ö., Yıldırım, G. & Reisoğlu, İ. (2012). Educational technology research trends in Turkey: A content analysis of the 2000-2009 decade. *Educational Sciences: Theory & Practice*, 12(1), 177-199.
- Johnson, B. & Christensen, L. B. (2004). *Educational research: Quantitative, qualitative, and mixed approaches* (2nd ed.) New York: Pearson Education.

- Kwiatkowski, T. & Silverman, R. (1998). Research fundamentals: II. Choosing and defining a research question. *Academic Emergency Medicine*, 5, 1114-1117. doi: 10.1111/j.1553-2712.1998.tb02673.x
- Laudon, K. & Laudon, J. (2009). *Management information systems: International Edition* (11/E ed.). Pearson Higher Education.
- Maddux, C. D. (2003). Selecting topics for journals: Some advice for beginners. *Computers in the Schools*, 20(4), 7-12.
- McMillan, J. H. & Schumacher, S. (2010). *Research in education evidence-based inquiry* (7th ed.). New Jersey: Pearson Education.
- Polonsky, M. J. & Waller, D. S. (2005). *Designing and managing a research project a business student's guide*. California: Sage.
- Shugan, S. M. (2003). Defining interesting research problems. *Marketing Science*, 22(1), 1-15. doi: 10.1287 / mksc.22.1.1.12848
- Tsui, A. S., Zhao, S. & Abrahamson, E. (2007). What to study in China? Choosing and crafting important research questions. *Management and Organization Review*, 3, 171181. doi: 10.1111/j.1740-8784.2007.00073



## Socioeconomic Determinant of Under Five Malnutrition in Nigeria

<sup>1</sup>Emeka Eze, <sup>2</sup>Obinna Osuji & <sup>3</sup>Justin Alugbuo

<sup>1,2&3</sup>Department of Economics,  
Michael Okpara University of Agriculture, Umudike, Abia State

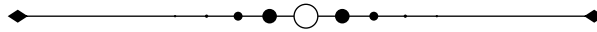

### **Abstract**

*Nigeria has one of the highest cases of child malnutrition in Sub-Saharan Africa. Considering the fact, the malnutrition leads to poor health outcomes which is inimical to adequate human capital development, understanding the socio-economic determinant of malnutrition in Nigeria is critical in informing policy going forward. This study is an attempt to identify the socio-economic determinant of malnutrition in Nigeria. Using data from the Nigerian Demographic and health survey 2018, the study estimated two Logistic regression model with stunting and wasting as the dependent variable, while, hhsz, wealth index, geographical Zone, mothers education, place of residence and sex of household head and other socio economic variables as independent variables. The study established that the richer the household, the less likely a child is going to suffer from malnutrition. The wealth status of a household was found to have a statistically significant impact in reducing child malnutrition in Nigeria in the period under review. The study also identified household size as one of the causes of child malnutrition. The study identified that higher household sizes increases the risk of stunting among children under five and the impact is also statistically significant in the period under review.*

**Keywords:** *Malnutrition, Socioeconomic variables, Nigeria*

---

### **Introduction**

Malnutrition is insufficient, excessive or imbalance consumption of dietary energy and nutrients (Smith & Haddad, 1999). There are three main indicators used to define malnutrition, i.e., underweight, stunting, and wasting. These indicators represent different



histories of nutritional insult to the child. (Bloss, Wainaina, & Robert, 2004). Stunting manifests in the form of linear growth retardation and occurs primarily in the first 2–3 years of life. It is frequently associated with repeated exposure to adverse economic conditions, poor sanitation, and the interactive effects of poor energy and nutrient intakes and infection. (Allen, 1994; Adair & Guilkey, 1997). On the other hand, underweight implies low weight-for-age and indicates a history of poor health or nutritional insult to the child, including recurrent illness and/or starvation, while a low weight-for-height is an indicator of wasting (i.e., thinness) and is generally associated with recent illness and failure to gain weight or a loss of weight. (Center for Disease Control and Prevention, 2003). One of the cardinal objectives of the sustainable development goals is the reduction in child mortality resulting from malnutrition and other diseases. However, eight years down the line, and barely nine years to the expiration of the time frame, the problem of child malnutrition is still prevalent and remains a big challenge in Nigeria despite efforts by successive government to improve child nutrition and eliminate the scourge of malnutrition. Evidence from the most recent Nigerian Demographic health survey (NDHS) 2018 data indicate that Nigeria has made little or no progress towards achieving the target for stunting, with 36.8% of children under 5 years of age affected, A value that is higher than the average for the Africa region (29.1%). 6.8% of children under 5 years of age are still affected by wasting, which is higher than the average for the Africa region (6.4%). and 7% are severely underweight.

Furthermore, the survey indicates that the proportion of children who are stunted is highest in the North West (57%) and lowest in the South East (18%). The proportion of children who are wasted is approximately twice as high in the North East (10%) and North West (9%) as in the other zones (4%-6%). Moreover, Children reported to be small or very small at birth are more likely to be stunted, wasted, or underweight than children reported to be average or larger at birth (NPC, 2019).

**Fig. 1**

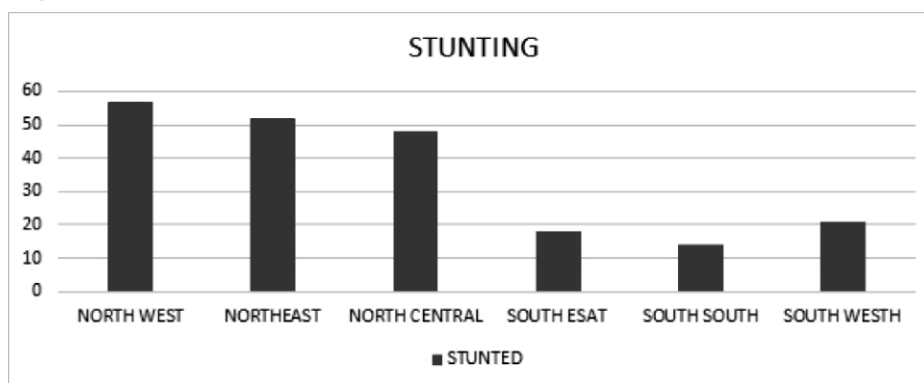

Incidence of stunting by geographical Regions in Nigeria. Source NDHS 2019.

A breakdown of the prevalence of malnutrition by socioeconomic characteristics highlights a more worrying trend. The proportions of children who are stunted, wasted, and underweight decline substantially with increasing mother's education and household wealth. For example, the prevalence of stunting is 54%, among children whose mothers have no education, as compared with 14% among those whose mothers have more than a secondary education

(NDHS, 2018). Furthermore, evidence from the National bureau of statistics (NBS) indicate that poverty is endemic and more pronounced in the northern region in Nigeria. Data published by the NBS 2019 indicate that the average poverty rate as measured by the poverty headcount ratio in the North West, North East and North central is 65%, 71% and 43% respectively. In the southern geographical region, the data shows that the value for the South East, South South and South West is 41%, 20% and 12% respectively.

Fig. 2

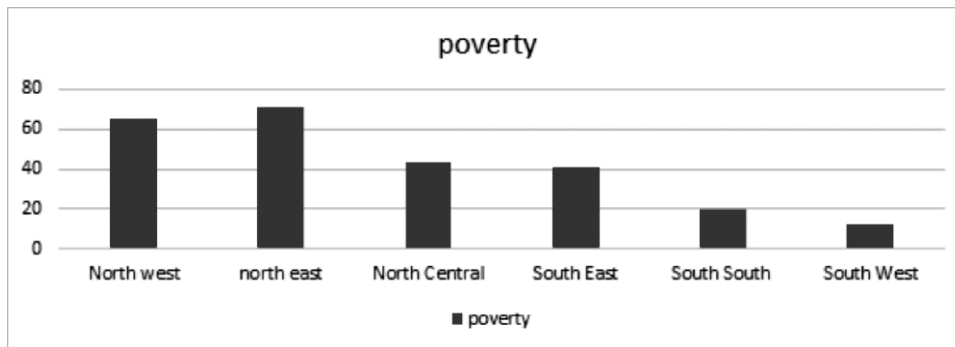

The economic consequences of malnutrition cannot be understated. Malnutrition slows economic growth and perpetuates poverty (World Bank, 2006). Mortality and morbidity associated with malnutrition represent a direct loss in human capital and productivity for the economy. At a microeconomic level, it is calculated that 1 percent loss in adult height as a result of childhood stunting equals to a 1.4 percent loss in productivity of the individual. In total, the economic cost of malnutrition is estimated to range from 2 to 3 percent of Gross Domestic Product, to as much as 16 percent in most affected countries. The effects of malnutrition are long-term and trap generations of individuals and communities in the vicious circle of poverty (World Bank, 2006). Several studies have sought to identify the socio-economic context of child malnutrition so as to better inform policy and programs aimed at improving child nutrition. A framework developed by UNICEF (2019) demonstrates that the underlying causes of malnutrition are multifaceted, including economic, social, and political factors. Poverty is recognized as both a cause and consequence of malnutrition. Akonbi et al, (2019) opines that malnutrition results from a complex interaction of contextual factors related to community, household, environmental, socioeconomic and cultural influences which has significant health consequences.

Despite the recognition of the relationship between socio economic inequality and child malnutrition, the ever-increasing base of literature on the subject suffers from some general methodological limitations. Although most scholars believe that there is a negative influence of poverty on children's health status and cognitive development, there is no clear consensus on how poverty should be operationalized. Researchers are beginning to recognize that poverty is not a single variable, but rather, can (and should) be represented in a variety of ways with respect to the resources it takes into consideration (e.g. considering wealth as well as income) and the period over which it is measured (e.g. multiple year averages) (Aber et al, 1997). Furthermore, recent data from the demographic and health survey in 2018 necessitates further studies into the current status of malnutrition in Nigeria and its interaction with socio economic variables in the country.

A proper understanding of the causes of childhood malnutrition will assist policy-makers in designing effective strategies which trigger better gains in child health and a further reduction in child mortality. Nonetheless, there exists quite a limited number of studies which investigate the patterns and causes of undernutrition in Nigeria Kamiya (2011). In the light of the above, the study seeks to answer the following questions

### **Research Questions**

- i. What is the impact of household poverty on under five malnutrition in Nigeria?
- ii. Does Mothers education have any impact on under five malnutrition in Nigeria?

### **Objectives of the Study**

- i. To determine the impact of Household poverty on under five malnutrition in Nigeria.
- ii. To evaluate the impact of mothers' education on child malnutrition in Nigeria

### **Hypothesis of the Study**

- i. Household poverty has no statistically significant impact on under five malnutrition in Nigeria.
- ii. Mothers education has no statistically significant impact on child malnutrition in Nigeria

### **Significance of Study**

The study can provide information that can be used for nutritional surveillance and targeting programmes that would focus more on populations most affected. The study also makes important contribution to literature by analyzing socio economic inequalities as a non-monetary measure of poverty which is a recent innovation in the literature. This is based on the argument that socio-economic inequalities like mother's education access to electricity, car ownership etc is a different dimension of welfare (capability deprivation) from income and expenditure. In addition, individual well-being in the form of nutritional status can be directly observed as opposed to household well-being. The study will improve the literature on child nutrition by carrying out a holistic analysis on the nexus between socio economic inequalities and malnutrition in Nigeria.

### **Scope and Source of Data**

The study will employ the Nigeria demographic and health survey (NDHS) data of 2018. The 2018 NDHS is a national sample survey that provides up-to-date information on demographic and health indicators. Specifically, information was collected on fertility levels, marriage, fertility preferences, awareness and use of family planning methods, child feeding practices, nutritional status of women and children, adult and childhood mortality, awareness and attitudes regarding HIV/AIDS, and female genital mutilation. The survey also assessed the nutritional status (according to weight and height measurements) of women and children in these households. In addition to presenting national estimates, the report provides estimates of key indicators for both rural and urban areas, the country's six geopolitical zones and 36 states, and the Federal Capital Territory (FCT)

### **Literature Review**

#### **Empirical Literature Review**

A study by Akombi, Agho, Renzaho, Hall and Merom (2015) examined the trend in socioeconomic inequalities in child undernutrition in Nigeria. Using cross-sectional data

from the Nigeria Demographic and Health Survey (NDHS) 2003 to 2013. The outcome variables were stunting, wasting and underweight among children under-five years. The magnitude of child undernutrition in Nigeria was estimated via a concentration index, and the socioeconomic factors contributing to child undernutrition over time were determined using the decomposition method. The concentration index showed an increase in childhood wasting and underweight in Nigeria over time. The socioeconomic factors contributing to the increase in child undernutrition were: child's age (0–23 months), maternal education (no education), household wealth index (poorest household), type of residence (rural) and geopolitical zone (North East, North West). To address child undernutrition, there is a need to improve maternal education and adopt effective social protection policies especially in rural communities in Nigeria. Duru et al 2015, studied the prevalence of malnutrition amongst children in selected rural communities in Imo state. The multi-stage sampling technique was used for the selection of subjects. Data was collected by direct measurement of anthropometric parameters as well as the use of a semi-structured questionnaire to obtain caregivers' information. The prevalence of overweight/obesity, underweight, wasting and stunting were, 9.8%, 28.6%, 23.6% and 28.1% respectively.

Endris, Asofa and Dube (2017) examined the prevalence of malnutrition among children aged 0–59 months in rural Ethiopia. Methods. Using data from 2014 Ethiopian Mini Demographic and Health Survey (EMDHS) A total of 3095 children were analyzed. The study found the prevalence rate of malnutrition among rural children in Ethiopia to be about 48.5% using a logistic regression model age of the children, preceding birth interval, educated status of mother, wealth status, and region were factors independently associated with nutritional status of children in rural Ethiopia. A child older than 12 months, having uneducated mother, living in a household with poor wealth status, born with short birth interval, and living in some region of the country are associated with increased odds of being malnourished. Meshram et al (2018) examined the Socio-demographic determinants of malnutrition among school going children in an urban slum area of central India. A total 361 school going children residing in urban slum area were included in study. Socio-demographic details of the children taken from their parents. Health check-up was done. The study found that the Prevalence of malnutrition was 40.17%. 17.17% children were underweight and 22.99% were stunted. The study established that that Family size and socioeconomic status are the important determinants of malnutrition. Kalu and Etim (2018) carried out a review of malnutrition-dependent factors among under-five children in developing countries. The study was carried out by reviewing publications on researches on malnutrition conducted in Africa and Asia with particular reference to factors associated with malnutrition. It was found that, of the 162 million children under five years who were stunted, 36% of them resided in Africa while 56% were found in Asia. It was also observed that an estimated 60 million under-five children in developing countries were found to be stunted out of which 11 million were Nigerian children. The severity of childhood malnutrition was observed to steadily increase from 11% in 2003 to 18% in 2013 for wasting; 24% in 2003 to 29% in 2013 for underweight, although there was a decline from 42% in 2003 to 37% in 2013 for stunted children. It was observed that high rates of mortality of malnourished children in Sub-saharan Africa result from factors such as low intake of calories, high rates of Human Immuno Virus/Acquired Immunodeficiency Syndrome (HIV/AIDS), political instability, conflicts among groups and poor implementation of government policies. For instance, 50% mortality of malnourished children in Malawi, Burundi and Madagascar were stunted as a result of poor dietary intake or

poor consumption of vital nutrient. Other major factors observed were poverty, absence of exclusive breastfeeding, maternal factors such as poor nutrition during pregnancy, lack of appropriate weight gain, poor consumption of vitamin supplement, illness, environmental factors, and socioeconomic/household factors, all of which affect the nutritional status of children. The study concluded that, governments of developing countries and the global community should work together to remove these factors.

Tette et al (2020) examined socio-demographic and health profiles of mothers of children with acute malnutrition and those without the condition. The aim of the study was to identify risk factors associated with malnutrition and focus on preventive efforts. The study employed an unmatched case-control study that was conducted in 2013 at PML, in Ghana in 2013. Mothers of children with moderate and severe acute malnutrition were compared with mothers of well-nourished children. Weight-for-height was used to classify malnutrition. Record forms and a semi-structured questionnaire were used for data collection.: A total of 371 mothers were studied consisting of 182 mothers of malnourished children and 189 mothers of well-nourished children. The study found that Low family income, unmarried status and type of child care were the main social determinants of malnutrition. These findings suggest that prevention and optimum management need to involve multidisciplinary teams consisting of health professionals, social workers and/or key workers to enable families at risk to access social care and social protection interventions (MDG 1). This will make the management of malnutrition more effective, prevent relapse, protect the next child and address maternal over-nutrition. le Roux, Nel and Walsh (2020) carried out a study to determine associations between demographic, health, and anthropometric indicators of mothers and their infants. A structured questionnaire was used to elicit information from 800 respondents who are mothers with 5- to 7-week-old babies visiting PHC facilities Age and length of the baby at 6 weeks were used to determine stunting, while the weight and height of the mother were measured for body mass index (BMI). Factors that determine malnutrition include weight and height of mother, smoking and alcohol consumption habits of mothers, living in informal housing vs. formal housing, smoking or using snuff during pregnancy, using alcohol during pregnancy and both smoking and using alcohol during pregnancy . the study confirmed the coexistence of under- and over-nutrition among mothers and their babies, possibly indicating that stunting in childhood may predispose to overweight and obesity in adulthood in a vicious cycle that affects generation after generation. Interventions aimed at poverty alleviation and encouraging healthy lifestyles with an emphasis on healthy eating, smoking cessation and abstaining from alcohol before pregnancy are urgently required.

## Methodology

### Model Specification

To capture the objectives of this study, which is to evaluate the impact of socio-economic inequality on child malnutrition the study will estimate two logit models: The first logit model will have stunting as the measure of malnutrition while the second model will have wasting as the indicator of malnutrition.

The Econometric specification of the Logit model is presented as:

$$L_i = \ln\left(\frac{P_i}{1-P_i}\right) = \beta_1 + \beta_2 \text{mothers\_edu} + \beta_3 \text{hhsz} + \beta_4 \text{wealth\_index} + \beta_5 \text{ph\_car} + \beta_6 \text{residence} + \beta_7 \text{zone} + \beta_8 \text{moth\_age} + \beta_9 \text{ph\_frig} + \beta_{10} \text{ph\_hhhead\_sex} +$$



**Table 1. Variables Description**

Variable	Description of variable.
$L_i$	Log of the odds ratio or logit
$\beta_1$	constant
$L_n$	natural logarithm
$P_i$	Probability that the child is stunted or wasting
$1-P_i$	Probability that the child is not stunted or wasting
stunted	A dummy variable that equals 1 if the child is stunted and zero otherwise
Wasting	A dummy variable that equals 1 if the child is Wasting and zero otherwise
Mothers years of education	Mothers years of education
Sex of hh head	A dummy variable that takes on the value 1 if household head is male and female otherwise.
hhsiz	Household size
Wealth_index	A variable that separates individual into 5 income classes, poorest, poorer, middle, richer, richest.
residence	A dummy variable that equals one if the individual lives in urban area and zero otherwise
Region	A variable that captures households' region of residence. 6 regions are used in the study viz: North Central, North West, North East, South East, South South and South West
ph_car	A dummy variable that equals 1 if the respondent is owns a car
Sex of household head	A dummy variable that equals one if the household head is a male and zero otherwise
Owns a refrigerator	A dummy variable that equals one if the household owns a refrigerator and zero otherwise

All data was obtained from the Nigeria demographic and health survey (NDHS) data of 2018 and extracted using stata 16.

### Model Justification

The logit model is a maximum likelihood estimation technique that is employed in estimating models that contains binary or dichotomous dependent variable. By using the cumulative distribution function (CDF), the Logit model ensures that the probability of success lies between 0 and 1 Gujarati (2004).

### Model Estimation and Interpretation

VARIABLES	(1)	(2)
	Model 1 Stunting	Model 2 Wasting
Owns a car or truck	-0.21** (0.104)	-0.04 (0.182)
hhsiz	0.04*** (0.007)	-0.02* (0.012)
Owns a refrigerator	-0.43*** (0.108)	-0.11 (0.170)
Sex of household head	-0.26***	-0.39***
Base group=1, poorest	(0.048)	(0.088)



wealth index combined = 2, poorer	-0.09 (0.072)	-0.26** (0.123)
wealth index combined = 3, middle	-0.25*** (0.084)	-0.25* (0.139)
wealth index combined = 4, richer	-0.41*** (0.103)	-0.30* (0.178)
wealth index combined = 5, richest	-0.58***	-0.41*
Base region= North central	(0.160)	(0.245)
region = 2, north east	0.62*** (0.094)	0.51*** (0.147)
region = 3, north west	0.96*** (0.088)	0.45*** (0.145)
region = 4, south east	-0.26** (0.109)	-0.06 (0.169)
region = 5, south south	-0.14 (0.109)	-0.15 (0.193)
region = 6, south west	0.23** (0.108)	0.03 (0.187)
Base Residence=1, Urban		
Place of residence = 2, rural	0.05 (0.065)	0.07 (0.114)
mother's years of education	-0.03*** (0.007)	-0.01 (0.012)
Constant	-0.30** (0.136)	-1.84*** (0.223)
Observations	12,091	12,146

Standard errors in parentheses  
 \*\*\* p<0.01, \*\* p<0.05, \* p<0.1

In Models 1 and 2 which has Stunting and Wasting as its indicators of malnutrition respectively, the Estimated logit models indicates that the wealth status of a household is a major determinant of child malnutrition in the country under consideration. As one moves through the income distribution from poorest 20% to the richest 20%, the log odds of a child under 5 being stunted reduces. Specifically, after controlling for all explanatory variables, the log odd that children born into richest the households will be stunted is 58 % lower compared to those born into the poorest household or the bottom of the income distribution. The impact is also statistically significant even at the 1% level. On the other hand, children from the richest households are about 41% less likely to suffer Wasting when compared to those from the bottom 20% of the wealth index. This is also statistically significant indicating that poverty affects malnutrition. This finding is in line with appriori economic expectations. Poorer families are often unable to consistently provide their children with high quality meals and medical attention that is required for healthy and proper growth. This finding is also in line with the findings of Akombi et al, 2019 who investigated the impact of poverty on malnutrition in Nigeria. The study also established that household size is positively related to the log odds of being stunted. This implies that as household size increases, the chances that a child under five years of age becomes stunted rises. Theoretically, this makes sense. As the household size increases, the number of resources available to each child decreases on the

average. This affects the amount of nutrition and care that the child can get as the meagre resources are divided up amongst an increasing number of children. Specifically, Model 1 estimates that all things being equal, increasing household size by one will increase the log odds of stunting by 4% on the average. It is also statistically significant.

On the hand, model two does not demonstrate any significant impact of household size on Wasting. In fact, the model suggests an inverse relationship between Wasting and household size. This finding is not in line with apriori theoretical expectations on the relationship between household size and child malnutrition. Mothers education reduces the log odds both stunting and Wasting amongst children under five. The impact of mother's education on stunting is about 0.7% and 1.2% for wasting. However, mother's education has no statistically significant impact on Wasting. Furthermore, the estimated model indicates that children born in the North West and North East have a high probability, of being stunted and Wasting compared to those born in the southern part of the country. The impact is also significant in both models. Owning a refrigerator or a car reduces the log odds of stunting but not Wasting while being born into a male headed household reduces both stunting and wasting.

### **Conclusion**

Nigeria has one of the highest cases of child malnutrition in Sub-Saharan Africa. Giving the fact that maintaining a healthy population as well as investment in human capital is critical to economic development, understanding the key determinant of malnutrition in Nigeria is critical in informing policy going forward. Understanding the socio-economic determinants of child malnutrition is very important in fashioning economic policies that will promote human capital development in a highly competitive global environment. Following an extensive review of theoretical and empirical literature, the study estimated two logistic regression model with stunting and wasting as the dependent variable, while, hhsz, wealth index, geographical Zone, mother's education, ownership of refrigerator, car ownership, place of residence and sex of household head as independent variables. The study established that the richer the household, the less likely a child is going to suffer from malnutrition. The wealth status of a household was found to have a statistically significant impact in reducing child malnutrition in Nigeria in the period under review. The study also identified household size as one of the causes of child malnutrition. The study identified that higher household sizes increases the risk of stunting among children under five and the impact is also statistically significant in the period under review. Similarly, the study found that children born to educated mothers are less likely to suffer stunting compared to those born to mothers without education.

### **Recommendations**

The study revealed a number of interesting results which have policy implications; hence it is recommended that:

- i. For government policies aimed at tackling malnutrition to be effective, it should be targeted at poorest household. This is very important as evidence have shown that children born into the bottom wealth quintile of the population are the most vulnerable. Providing some form of support through feeding programs, medical care or cash tranfers can help improve the health outcomes of children in this income grouping.
- ii. Educating households on the need to reduce household size through the reduction in

- child bearing. In this regard, family planning techniques should be introduced and emphasized especially in areas where there is a high prevalence of malnutrition like the Northern part of the country and amongst rural dwellers in general.
- iii. Emphasis should be placed on girl child education as this has been shown to be effective in reducing child malnutrition in Nigeria.

### References

- Adair, L. S, & Guilkey, D. K. (1997). Age-specific determinants of stunting in Filipino children. *J Nutr*, *127*, 314–20.
- Akombi, B. J., Agho, K. E., Renzaho, A. M., Hall, J. J. & Merom D. R. (2019). Trends in socioeconomic inequalities in child undernutrition: Evidence from Nigeria demographic and health survey (2003–2013). *PLoS ONE* *14*(2), e0211883).
- Ali, M. A. Batu, M. M. & Kaushik, K. K. (2016). Socio-economic determinants of nutritional status of children in Ethiopia. *International Journal of Scientific and Research Publications*, *6*(3).
- Awoyemi, T. T., John, C., Odozi, C. J. & Ogunniyi, A. A (2012). Environmental and socioeconomic correlates of child malnutrition in Iseyin Area of Oyo State, Nigeria. *Food and Public Health*, *2*(4), 92-98.
- Babatunde, O. R., Olagunju, I. F., Bamidele, S. & Sola-Ojo, E. F. (2011). Prevalence and determinants of malnutrition among under-five children of farming households in Kwara State. *Nigeria Journal of Agricultural Science*, *3*(3).
- Bloss, E., Wainaina, F. & Robert, C. (2004). Bailey prevalence and predictors of underweight, stunting, and wasting among children aged 5 and under in Western Kenya. *Journal of Tropical Pediatrics*, *50*(5).
- Center for Disease Control and Prevention (2003). Epi-Info Manual. NutStat: A Nutritional Anthropometry Program. Epidemiology Program Office. Division of Public Health Surveillance and Informatics. Retrieved from <http://www.cdc.gov/epiinfo/epimanual.htm>
- Duru, B. C., Oluoha, R. U., Uwakwe, A. K., Diwe, C. K., Merenu, A. I., Chigozie, O. I. & Iwu, C. A. (2016). Prevalence and sociodemographic determinants of malnutrition among under-five children in rural communities in Imo State, Nigeria. *American Journal of Public Health Research*, *3*(6). doi: 10.12691/ajphr-3-6-1

- Endris, N., Asefa, H., & Hindawi L. D. (2017). Prevalence of malnutrition and associated factors among children in rural Ethiopia. *BioMed Research International*, 6. Retrieved from <https://doi.org/10.1155/2017/6587853>
- Jatinder, K. G. (2010). Child malnutrition: Trends and issues. *The Anthropologist*, 12(2), 131-140. DOI: [10.1080/09720073.2010.11891143](https://doi.org/10.1080/09720073.2010.11891143)
- Kalu, E. R. & Etim, D. K. (2018). Factors associated with malnutrition among under five children in developing countries. *A Review Global Journal of Pure and Applied Sciences*, 24, 69-74.
- Kamiya, Y. (2011). Determinants of nutritional status of children in Laos. *Journal of Health Population and Nutrition*, 29(4), 339-348.
- le Roux, M. N. & Walsh, C. (2020). Determinants of stunting at 6 weeks in the Northern Cape Province, South Africa. *Front. Public Health* 8,166. doi: 10.3389/fpubh.2020.00166
- Meshram, T. T. (2019). Socio-demographic determinants of malnutrition among school going children in an urban slum area of central India with special reference to nutritional Anaemia. *International Journal of Community Medicine and Public Health*, 5(9), 4009-4011.
- National Nutrition and Health Survey (NNHS) 2018.
- National Population Commission (NPC) [Nigeria] and ICF. 2019. Nigeria Demographic and Health Survey 2018. Abuja, Nigeria, and Rockville, Maryland, USA: NPC and ICF.
- NDHS; Nigeria Demographic and Health Survey (2018)
- Repositioning Nutrition as Central to Development (2006). A strategy for large-scale action. The World Bank.
- Smith, L. C. & Haddad, L. J. (1999) Explaining child malnutrition in developing countries: A cross-country analysis. Research Reports 111, International Food Policy Research Institute, Washington DC.
- Tette, E. M. A., Sifah. E. K ., Nartey, T. E. , Nuro-Ameyaw, P., Tete-Donkor, P. & Biritwum, B. R. (2016). Maternal profiles and social determinants of malnutrition and the MDGs: What have we learnt? *BMC Public Health*, 16, 214. DOI 10.1186/s12889-016-2853-z
- UNICEF (2021). Malnutrition in Nigeria
- USAID (2018). Nigeria: Nutrition profile
- World Health Organization (2021). Malnutrition. Retrieved from [https://www.who.int/health-topics/malnutrition#tab=tab\\_1](https://www.who.int/health-topics/malnutrition#tab=tab_1).



## Impact of Project Based Strategy on Students Retention and Performance in Biology Concept for Entrepreneurial Skills Acquisition among Secondary School in Zaria, Kaduna State

Ezeaghasi, Ngozi Eucharua  
Department of Biology,  
School of Secondary Education Sciences,  
Federal College of Education, Zaria.

---

### Abstract

The study examined the Impact of Project-based Strategy on Acquisition of Entrepreneurial Skills, Retention and Performance in Biology Concept, among Secondary School Students, in Zaria local Government Area, Kaduna State, Nigeria. The study adopted pre-test, post-test, post post test quasi-experimental design. The population consisted of 7437. Fifteen public senior secondary school were involved. Three secondary schools were purposively sampled. The sample size was 174 which consist of (87 males and 87 females) SSII Biology students using Two Experimental groups (EG1&EG2) and one Control Group (CG). Three instruments were used for the study; (1) Biology Concept Entrepreneurship Test (BCET), (2) Entrepreneurial Skill Acquisition Test (ESAT) and (3) Biology Performance Test (BPT) the instruments were validated by experts in the field. The reliability coefficients of the instruments using PPMCC were estimated at  $r = 0.71$ ,  $r = 0.78$  and  $r = 0.68$  respectively. Descriptive statistics in form of mean, standard deviation and standard error were used to answer research questions, *t*-test, Scheffe test, ANOVA and ANCOVA at  $P \leq 0.05$  level of significance were used in testing the Null Hypotheses. The findings revealed that there was significant difference in performance mean scores of students taught biology concepts for entrepreneurship using Project-based Strategy. There is significant difference in students 'retention ability levels in skills acquisition using DATS as assessment tool over those exposed to TFLE as assessment tools of Project-based Strategy in biology. Based on the findings recommendations were made one of which was that Project exhibition of finished products should be encouraged in schools as it develops in students' occupational knowledge, job skills, work experience, and this makes self-employment and business ownership a viable and appealing goals for today 's students.

**Keywords:** Project based strategy, Students retention, Biology, Entrepreneurial skills acquisition, among Secondary school.

---



## **Introduction**

Effective education is an approach to teaching and learning that focuses on creating meaningful learning experiences for students. It involves engaging students in active learning, providing them with relevant and meaningful content, and creating an environment that encourages collaboration and critical thinking (Anfafuwa, 2017). The importance of assessment and feedback is to ensure that students are learning and making progress which is the emphases of effective learning. Education helps develop the skills and knowledge in students which they need to be successful in life and become lifelong learners. One of the ways to achieve these is through biology education. Biology is an applied field of study built upon many disciplines for the purpose of achieving and maintaining the wellbeing of individuals in an ever changing society and also opens up new pathways for economic growth, because students can use their understanding of the natural world to develop innovative solutions to global problems (Rao & Sri 2019). One of the main aims of biology education is to Encourages students to think critically about the environment to prepare students for careers in the sciences, as well as provide them with the knowledge and skills they need to make informed decisions about their lives. Through biology education students gain critical thinking and problem-solving skills that are essential for a successful career in the modern economy, Okafor and Nwanaka, (2022). Many areas in biology education exposes the students in acquisition of certain skills which is entrepreneur. Entrepreneurial skill is designed for students towards self- determination, self-employment and self-reliance in their different field of knowledge (Agbenyeku, 2020). It can be seen as training which includes a systematic and planned effort to develop knowledge and skills, attitudes, motivation and ability to develop business mind in trying to survive and contribute to national growth and development (Ogbounu, 2015 and Ukpai, 2020). Entrepreneurial skills in biology according to Mohammed (2019) includes: i. Food and water quality control skills: for example, pure water choose from the content of water and sanitation in Biology. ii Food and beverages production skills: For example, fermentation of beverages to make local wine, choose from the content of nutrition. Animal production skill: For example (a) fish farming or aquaculture (b) Rabbiting (c) Poultry production (d) Api culture (e) Animal fattening and production (Mohammed, 2019).

Project teaching approach is an educational strategy in which students solve practical problems over a period of several lessons, days or weeks This may be carried out individually or in group under the guidance of the teacher to achieve set objectives (NTI, 2001); with these students acquired skill of mind-on, hand-on and heart-on-activity, with hand-on-activity (psychomotor) having more emphasizes. Project-based Strategy engages students working under freedom and autonomy to decide on what and how to learn or acquire skill at their own pace. Oghenevewede (2022) opined that biology is centered to science education which involved exposing students to several opportunities that can help them to be useful to the society as well as understand different type of concepts, principles and theories. Obialor, Osuafor and Nnadi (2017) and Eita and Ashipla, (2020) further supported that the investigative procedures of Project-based pack, enables students gain valuable academic knowledge, practical skills, develop ability to solve problems in real life situation and promote motivation as they work together as a team. Biology education is prerequisite to the study of some professional courses like medicine, pharmacy and agriculture (Bello, Alabi, Ahmed, Sulaiman, Bello & Bello). Some concepts in Biology possess profitable entrepreneurial skill if carefully identified (Nwagbo,2019); Okafor and Nwanaka, (2022) reported that Biology graduates should be able to acquire skills and undertake the production of the goods and



services from the following concepts of biology on commercial scale for self-reliance and self-employment (Cakici & Tuckmen 2013., Kadala 2014 & Mohammed 2019). Fento, Manuel and Mukundu (2013) affirmed that no single method is best for the teaching of science especially biology and concluded in their studies that student's performance significantly improved with Project-based activities (Atsuwe, & Anyebe 2016).

Project-based Strategy through entrepreneurship means the functional process of teaching and learning that aim at bringing together creative and innovative ideas coupled with managerial and organizational skills in order to combine people, money and resources to meet an identified need and create wealth for livelihood (Ajala, Famuwagun, & Adebimpe, 2021). Project based approach is a teaching and learning model which emphasise Student-centred instruction by assigning project or learning task to students so as to be constructive in knowledge and skill acquisition Dennis, Paul & Inyang, 2021). Project-based approach can be carried out in the following approaches or forms: (a) The Preparatory Approach /Form: (b) The Constructive Approach/Form (Okeke, Eghunonu & Ughaja, 2009). The following strategies or approach can be carried out in the following stages: There are four stages in using Project-based approach as outlined by NTI (2001), a. Panning stage b. Class or site organization stage c. Project implementation stage d. Assessment stage. Gender is one of the variables used for this study. Gender was taken into cognizance in order to find out whether or not teaching Biology concept using Project-based Strategy will have impact on the Acquisition of Entrepreneurial Skills, Retention and their academic Performance .Some studies revealed that male students have a head start advantages over female students Kajuru (2015), Olarewaju (2012), Kadala (2014) while some revealed that female performed better. While some studies disagreed and state that the approach or strategy is gender friendly (Mohammed 2019).

### **Statement of the Problem**

Researcher have found a number of factors that have been identified as contribution to the non-acquisition of skill by secondary school students which invariably lead to students' poor performance and students' retention ability Dennis, Bassey, & Paul (2021) and Okafor and Nwanaka, (2022). One out of the factors is teachers' inability to navigate through the use of varieties of teaching methods by considering hand-on activities. Fenton *et.al*, (2013) reported that despite awareness of project-based instructional strategy, lecture method remains the frequently used teaching method by teachers even in a practical lesson. This study therefore, investigated the impact of project-based strategy on students' retention and performance in biology concept for entrepreneurial skills acquisition among senior secondary school in Zaria, Kaduna state.

### **Objectives of the Study**

#### **The Objectives of the Study Include:**

1. To investigate the impact of Project-based Strategy on students' academic performance in Biology
2. To determine the impact of Project-based Strategy on students' retention of Biology concepts
3. Investigate the impact of Project-based Strategy on students' entrepreneurial skills acquisition on retention ability
4. To examine the impact of Project-based approach on male and female students

taught

5. Examine the students' level of entrepreneurial skills acquisition using Project-based approach assessment tools

### Research Questions

- i) What is the impact of Project-based Strategy on students' academic performance in Biology?
- ii) What is the impact of Project-based Strategy on students' retention of Biology concepts?
- iii) What is the impact of Project-based approach on students' retention ability to acquire entrepreneurial skills in Biology?
- iv) What is the difference in the performance mean scores of male and female students taught using Project-based Strategy in Biology?
- v) What is the difference between levels of entrepreneurial skill acquired using Project-based Approach assessment tools (DATS and TFLE)?

### Null Hypotheses

- Ho<sub>1</sub>:** There is no significant difference between students' means academic performance scores in Biology concept taught using Project-based Strategy and those taught using lecture methods
- Ho<sub>2</sub>:** There is no significant difference between the retention ability mean scores of students taught Biology concepts using Project-based approach and that taught the same concept using lecture method
- Ho<sub>3</sub>:** The students' acquisition of entrepreneurial skills when taught biology concept using Project-based approach and lecture methods
- Ho<sub>4</sub>:** The mean academic performance scores of male and female students taught biology concept does not differ significantly using Project-based Strategy only
- Ho<sub>5</sub>:** There is no significant difference in students' retention ability levels in entrepreneurial skills acquisition using Project-based Strategy assessment tools (DATS and TFLE)

### Methodology

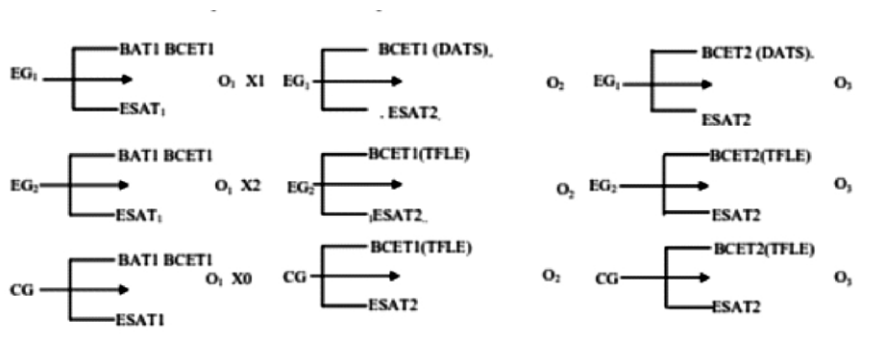

Fig. 1: Research Design

**Key:**

EG1= Experimental Group 1

EG2 =Experimental Group 2

CG= Control Group

X1= PA = Project-based Approach Using Training Manual in Fishery and Poultry (DATS).

X2 = PA = Project-based Approach Using Training Manual in Fishery & Poultry (TFLE).

X0 = TLM = Traditional Lecture Method Using Training Manual in Fishery & Poultry (TFLE).

O1 = Pre-test using BAT1, BCET1 and SAT1.

O2 = Post-test using BCET2 (DATS); BCET2 (TFLE) and SAT2.

O3 = Post post-test using BCET2 (DATS); BCET2 (TFLE) and SAT2.

BPT1 = Biology Performance Test 1

BCET1 = Biology Concepts for Entrepreneurship Test1 (poultry and fishery)

BCET2= Biology Concepts for Entrepreneurship Test 2 (poultry and fishery)

DATS = Diagnostic Adaptive Testing Skill (Adapted from Opatale, (2009)

TFLE=Traditional Fix Length Examination

ESAT1 = Skill Acquisition Test 1

ESAT2 = Skill Acquisition Test 2

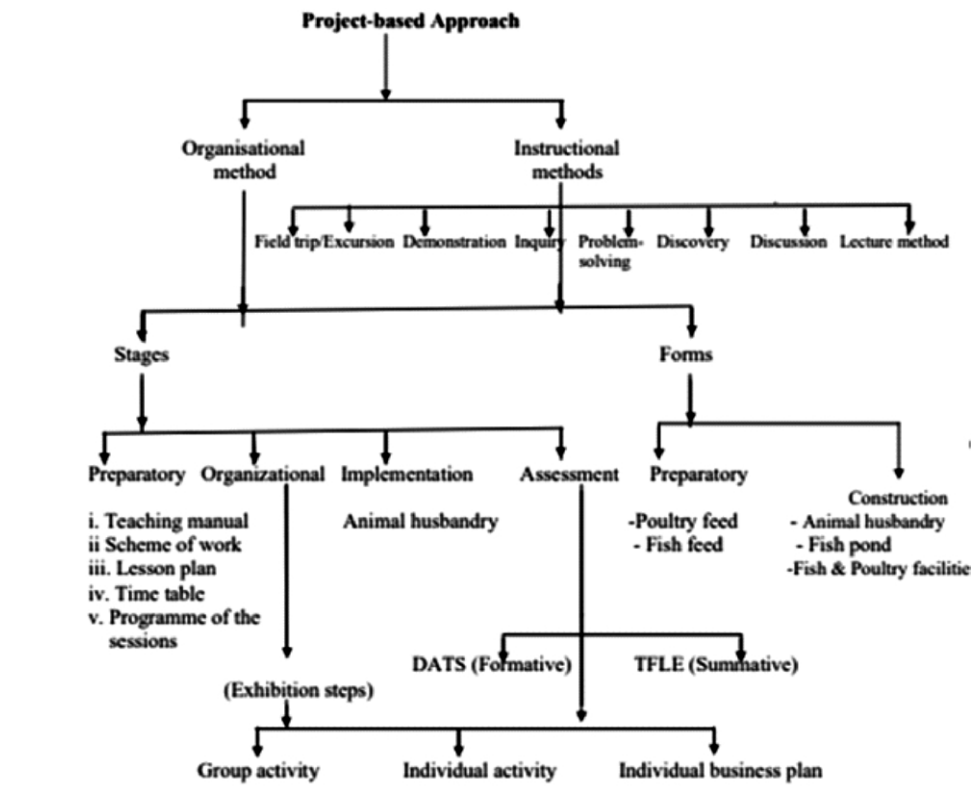

Fig 2: Flow Chart of Project-Based Approach. Adapted from SMASE, (2010)

The research design adopted for this study was quasi experimental design of two experimental groups (EG1 & EG2) and one Control group (CG) involving Pre-test, Posttest and Post-posttest. The population of this study consisted of all public senior secondary school students (SS2) in Zaria Local Government Area, Kaduna State, consisting of about seven thousand four hundred and thirty-seven (7437). The sample of 174 was drawn from public senior secondary schools (SSII biology students). As seen in table 1.

**Table 1: Sample of the Study**

S/N	Name of schools sampled	Experimental group	Male	Female	Total
1	Government Senior Secondary School Dakace	EG1	29	29	58
2	Government Senior Secondary School Kufena, Zaria	EG2	29	29	58
3	Government Senior Secondary School Magajiya, Zaria	CG	29	29	58
	Total		87	87	174

Selection of the sample subjects were carried out by simple random sampling technique by ballot system. 58 students (29 male and 29 female students) were selected from each sampled school. They were given pre-test on Skill Acquisition Test1 (SAT1) to determine level of skills acquired. The students were grouped into groups of 5 subjects for skill acquisition in Poultry and Fishery.

### Instrumentation

The research instruments for the study includes: Biology Performance Test (BPT); Biology Concepts for Entrepreneurship Test (BCET) using Diagnostic Adaptive Testing Skills (DATS); Biology Concepts for Entrepreneurship Test (BCET). Using Traditional Fix Length Examination (TFLE); Entrepreneurial Skills Acquisition Test (ESAT). The instruments were used in the collection of data on students. BPT consists 30 items of multiple choices questions which was drawn from past WAEC questions, Biology Syllabus and Scheme of Work to test for academic equivalence between the sample schools. The instruments were validated by two (2) Senior Lecturers with Ph. D qualification from A.B.U. Zaria. Also, a senior staff from biology education with a minimum of first degree in biology and working experience of not less than 20 years was used to validate the instruments from the schools. BCET, ESAT and BPT instruments were validated using content validity because the instruments were administered considering specific content areas, validity, coverage and behaviorally stated instructional objectives. The reliability coefficients of the instruments using PPMCC were estimated at  $r = 0.71$ ,  $r = 0.78$  and  $r = 0.68$  respectively. Descriptive statistics in form of mean, standard deviation and standard error were used to answer research questions, t-test, Scheffe test, ANOVA and ANCOVA at  $P \leq 0.05$  level of significance was used in testing the Null Hypotheses.

### Results

#### Answering Research Questions

The mean academic performance scores and standard deviation of Project-based Strategy using DATS was used for EG1 while Project-based approach using TFLE was used for EG2. The data from the two Strategies were compared with the Lecture Method as Control Group (CG).

**Research Question 1**

What is the impact of Project-based Strategy on students' academic performance scores in Biology? The mean and standard deviation of student's posttest scores were calculated and summary is presented in table 2.

**Table 2: Summary of Mean Scores, standard deviation and standard error of post-test among SS2 Students taught biology concept using Project-based Strategy and those taught using to Lecture Method**

Group	N	Mean	SD	SE
Experimental group 1	58	54.64	17.32	3.44
Experimental group 2	58	39.62	10.52	2.12
Control group	58	35.74	9.92	1.98

Table 2 reveals that the mean performance scores of students from EG1 using Project-based Strategy (DATS) was 54.64 while the mean performance scores of students in EG2 using Project-based Approach (TFLE) was 39.62 and Control Group (CG) using Lecture Method was 35.74. The results from Table 2 shows that the performance mean score of students exposed to Project-based Approach using DATS (EG1) was higher than those exposed to Project-based Approach using TFLE(EG2) and in turn higher than those taught using Lecture Method (CG).

**Research Question 2**

What is the impact of Project-based Strategy on students' retention ability of the learned Biology concept? The mean and standard deviation of student's post posttest scores were calculated and summary is presented in table 3.

**Table 3: Summary of Comparing Retention Mean Scores among SS2 Students Taught using Project-based Approach and those Expose to Lecture Method**

Group	N	Mean	SD	SE
EG 1	58	66.38	10.37	2.08
EG 2	58	50.60	8.96	1.80
CG	58	42.01	9.30	1.81

Table. 3 shows that the mean scores of students' retention of biology concepts when exposed to Project-based Strategy (EG1&EG2) and those taught using Lecture Method (CG) were 66.38,50.60 and 42.01 respectively. The mean score of the experimental Group 1 (EG1) students' retention of biology concepts for entrepreneurship was higher than Experimental Group2 (EG2). The Control Group (CG) had the least retention mean score of biology concepts learned.

**Research Question 3**

What is the Impact of Project-based Strategy on students' retention ability to acquired skills in Biology Concept? The mean, standard deviation and standard error of student's post posttest scores were calculated and summary is presented in table 4.

**Table 4: Summary of Students' Retention Ability Skill Mean Scores When Exposed to Project based Strategy in Biology Concepts for Entrepreneurial Skills.**

Group	N	Mean	SD	SE	Remark
EG 1	58	82.56	10.09	1.48	High skill
EG 2	58	64.66	11.98	1.48	Moderate skill
CG	58	49.98	12.40	1.48	Low skill

Table 4. reveals that students' retention ability level when exposed to Project-based approach using DATS has the mean retention ability score of 82.56 and acquired High Skills which is higher than students exposed to Project-based approach using TFLE (EG2) with retention mean ability score of 64.66 and acquired moderate skills while students taught using Lecture Method (CG) had lowest mean retention ability score of 49.98 with Lower Skills.

**Research Question 4:**

What is the difference in the academic performance mean scores of male and female students taught biology concept using Project -based Strategy? The mean and standard deviation of student's posttest scores were calculated and summary is presented in table 5.

**Table 5: Summary of Mean Scores of Male and Female Students taught biology concept using Project -based Strategy.**

Group	N	SEX	Mean	SD	SE
EG 1	29	Male	52.86	17.56	1.77
		Female	56.50	14.26	1.77
EG 2	29	Male	44.12	11.98	1.77
		Female	37.00	9.93	1.77
CG	29	Male	34.42	9.43	1.77
		Female	34.75	9.23	1.77
TOTAL	87	Male	43.86	15.239	1.48
		Female	42.82	15.048	1.48
	174	Total	43.32	15.111	1.48

Table 5 shows the mean performance scores of male and female students in EGI to be 52.86 and 56.50 respectively. The result indicated that the female mean performance score was higher than male mean performance scores. The students in EG2 had mean performance scores of male and female students as 44.12 and 37.00 respectively, showed that the male mean performance scores were higher than female mean performance score in EG 2. In the CG the mean performance scores of male and female students were 34.42 and 34.75 respectively, with the female mean performance scores was higher than male mean performance score. Finally, the total performance mean score between male and female students were 43.63 and 42.75 respectively and was slightly higher in favour of male students.

**Research Question 5:**

What is the difference between levels of skill acquired using DATS and TFLE as assessment tools for Project-based approach? The mean and standard deviation of student's posttest scores were calculated and summary is presented in table 6.



**Table 6. Mean Scores of students taught biology concept using DATS and TFLE Assessment Tools on Acquisition of Skills among SS 2 Students**

Group	N	Mean	SD	SE	Remark
EG 1	58	68.48	10.42	1.409	Moderate skill
EG 2	58	58.24	11.56	1.415	Moderate skill
CG	58	45.98	12.56	1.398	Low skill

Table 6 reveals that after teaching the students using DATS as assessment tool (formative) in evaluating the level of skills acquisition in EG1, the Mean Score was 64.48 which shows that students acquired Moderate skills. In EG2, it shows that the students acquired Moderate skills with the Mean Score of 58.24 after exposing of students to Project-based Approach using TFLE as assessment tool (summative) in evaluating their level of skills acquisition. The students in EG1 recorded the higher mean score than the students from EG2 with mean in entrepreneurial acquisition of skills in biology. While the least was the control group (CG) with the mean score of 45.98 also with low Skills.

#### Testing of Null Hypotheses

**HO<sub>1</sub>:** There is no significant difference between students' academic performance mean scores in Biology concept taught using Project- based strategy and those taught using Lecture Method. To test this hypothesis, the posttest means scores of students were subjected to ANOVA and results obtained were shown in table 7.

**Table 7: Summary of ANOVA on Mean Academic Performance Scores among SSII Biology Students**

EG1, EG2, CG	SS	Df	MS	F	Sig	Remark
Between groups	1064.06	2	5372.54	34.87	.000	S*
Within groups	23627.69	172	160.634			
Total	33998.88	174				

**Significant at  $P \leq 0.05$**

Table 7 shows that significant difference existed among students taught biology concept using Project based strategies in experimental group (EG1&EG2) and those taught using lecture method (CG) at  $P = .000$  at  $P \leq 0.05$  level of significance. The null hypothesis which states that there is no significant difference in students means scores in biology taught using Project-based approach and their counterpart taught using lecture method is rejected.

**HO<sub>2</sub>:** There is no significant difference between the retention mean scores of students taught Biology concepts using Project-based approach and those taught using Lecture Method. To test this hypothesis, the post posttest means scores of students were subjected to analysis using ANOVA and result were shown in table 8.

**Table 8: Summary of ANOVA Test on the Difference in Retention Mean Scores in Biology among SSII Students**

EG1, EG2, CG	SS	Df	MS	F	sig	Remark
Between groups	153467.895	2	7667.568	86.006	.000	S*
Within groups	13379.980	172	88.646			
Total	28854.822	174				

Table 8: reveals that there is significant difference in retention ability level of students taught using Project-based approach (EG1 & EG2) and those students taught using lecture method (CG). The calculated P-value of 0.000 which is less than  $P \leq 0.05$  alpha level of significance when compared between EG1 and EG2 with CG groups. To identify the cause of the effect for the significant difference, Post -hoc Scheffe Test was conducted as shown in the Table 9 below. However, based on the statistical evidence that the p calculated was lower than the alpha level of 0.05, the null hypothesis which states that there were no significant differences between retention mean scores of students taught biology using project-based approach and those taught using lecture method is rejected.

**Table 9: Summary of Post-Hoc Scheffe Test on the difference in Retention Mean Scores in Biology among SSII Students**

Group	Group J	MD(1-J)	SE	P-Value	Remark
Scheffe	EG 2	16.320	1.964	.000	S*
EG 1	CG	22.420	1.964	.000	S*
EG 2	EG1	-16.320	1.964	.000	S*
	CG	6.100	1.964	.000	S*
CG	EG1	22.420	1.964	.000	S*
	EG 2	-6.100	1.964	.000	S*

**\*Significant at  $P \leq 0.05$**

Table 9 shows that the retention mean Scores between students exposed to Project-based approach using DATS (EG1) and Project-based approach using TFLE (EG2) is statistically significant showing that the calculated P value of 0.00 which is less than 0.05 alpha value of significance. The above findings showed significance difference therefore the stated null hypothesis is rejected.

**HO<sub>3</sub>:** There is no significant difference in students' means scores on retention in acquisition of skills when expose to Project-based approach and their counterparts taught using lecture method.

To test the significant difference, univariate test was conducted to ascertain that contrasting characteristics of the significant difference. This is shown in the Table 10 below

**Table 10: Univariate Test of the Retention Ability Mean Scores of the Three Groups (EG1, EG2&CG) of Students on Acquired Skills**

EG1,EG2,CG	SS	Df	MS	F	Sig	Remark
Contrast	26545.623	2	12739.316	118.408	.000	S*
Error	15627.810	172	109.218			

\*Significant at  $P \leq 0.05$

Table 10 shows that there is significant difference in the students' retention ability based on the mean Scores of the three groups EG1, EG2 and CG. Showing the calculated F value of 118.408 at  $P \leq 0.05$  level of significance. The calculated P value is 0.000 at  $P \leq 0.05$  level of significance. This shows that retention ability differs among the students in the three groups. Two by two pairwise comparison was used to find out the causes in the difference between the groups in Table 11.

**Table 11: Post Hoc Scheffe Test on Retention Ability to Acquired Skills in Biology**

Method	Group J	MD(1-J)	SE	Sig	Remark
Scheffe	EG 1	18.240	2.096	.000	S*
	EG 1	CG	32.980	2.096	.000
EG 2	EG 1	-18.240	2.096	.000	S*
	CG	15.530	2.096	.000	S*
CG	EG1	-32.980	2.096	.000	S*
	EG2	-15.530	2.096	.000	S*

\*Significant at  $P \leq 0.05$

Table11 reveals that there is significance difference among the three groups. The retention means difference scores between EG1 and EG2 is 18.240 in favour of EG1. EG1 enhanced acquisition of skills better than EG2 significantly. Also, the retention means difference scores between EG1 and CG is 32.980 which is in favour of EG1. Thus, EG1 acquire entrepreneurial skills than CG. Between EG2 and CG the retention means difference scores of 15.530 is in favour of EG2. Therefore, EG2 can enhance acquisition of skills better than CG. Thus, EG1 is significantly better and enhanced retention ability than EG2, while EG2 enhanced retention ability than CG among SS2 students in acquiring skills in biology.

#### HO<sub>4</sub>:

The mean academic performance scores of male and female students taught biology concept does not differ significantly using Project-based Strategy only. To test this hypothesis, the Univariate Test was conducted and summary shown in table 12.

**Table 12: Summary of Univariate Test on Performance Mean Scores of Male and Female Students after Exposure to Project-based Strategy in Biology**

Male & female group	SS	Df	MS	F	Sig	Remark
Contrast	32.643	2	32.840	.202	.654	NS*
Error	22637.890	168	158.833			

\*Significant at  $P \leq 0.05$

Table 12 reveals that there is no significant difference on the performance mean scores between male and female students with calculated p value of 0.654 which is considered greater than  $P \leq 0.05$  level of significance. Therefore, the stated null hypothesis is thereby retained. This implies that gender has no significant effect on performance in biology when exposed to Project-based approach.

**HO<sub>5</sub>:** There is no significant difference in students' ability levels in skills acquisition using DATS as assessment tool and those expose to TFLE as assessment tools of Project-based approach. To test this hypothesis, the data was subjected to two-way ANOVA

**Table 14: Summary of Two-way ANOVA on Mean Scores Difference after Exposure to DATS and TFLE (Assessment Tools on acquisition of Skills)**

EG1,EG2,CG	SS	Df	MS	F	P-Value	Remark
Between groups	8523.122	2	4287.060	30.998	.000	S*
Within groups	20005.383	171	138.024			
Total	28456.502	173				

**significant at  $P \leq 0.05$**

Table 14. reveals that there is significant difference between students' ability level in skills acquisition using DATS as assessment tool and those expose to TFLE as assessment tool of Project-based approach with F value of 30.993 and calculated P value of 0.00 at  $P < 0.05$  level of significance. Therefore, the hypothesis which states that there is no significant difference in students' ability level in skills acquisition using DATS as assessment tool and those expose to TFLE as assessment tool of Project-based approach is rejected. The direction of significance difference between the approaches was in favour of EG1.

### Discussion

The results from table 2 shows that the performance mean score of students in EG1 is higher than EG2 and in turn higher than CG. Meaning that the students exposed to Project-based Strategy using DATS in (EG1), performed better than students taught using Project-based approach using TFLE (EG2) while students exposed to Lecture Method possess the least performance. This finding agreed with the findings of Cakici and Tuckmen (2013), Kadala (2014), Atsuwe and Anyebe (2016) and Mohammed (2019) and Dennis, Bassey, Paul and Inyang (2021) which opined in their different studies that students' performance improved significantly with Project-based activities. They stressed that, the students' performance mean scores in biology through the use of Project-based approach over lecture method could be attributed to its characteristics nature of activity-based oriented method that is product or practical result oriented.

The results from Table 3 shows that the retention mean scores of students exposed to Project-based approach (EG1&EG2) in biology was higher than those taught using Lecture Method (CG). This finding was in line with work of Agbayaku (2012) and Mohammed (2019), that the experimental group taught ecological concepts using Project based approach and Outdoor Laboratory Approach retained and achieve significantly higher than those exposed to Lecture Method. The results from ANOVA test obtained from Table 8 of this work was to test significant difference of the null hypothesis which stated that there is no significant

difference between the retention means scores of students taught Biology concepts using Project-based approach and that taught using lecture method. Thus, the null hypothesis based maintained that significant difference exist between all experimental groups (EG1, EG2) with control group(CG) in terms of retention ability level of biology students. the result of the finding accords with the findings by Agbayaku (2012), Kadala (2014 and Mohammed (2019) that retention of Biology concepts requires the activity-based strategies.

Result from Table 4 reveals that students retention ability level in acquisition of skill when exposed to Project-based approach using DATS has the highest mean retention ability score and acquired high Skills than those exposed to lecture method with Low Skills. This study agreed with findings of Mohammed (2019) who stressed that the extent of entrepreneurship skill acquisition in biology through designed project approach was moderate, while those exposed lecture methods acquired low skill. Therefore, the research question was answered using the corresponding hypothesis in table10. The ANOVA results from Table 10 shows that there was significant difference in the students' retention ability means scores among the three groups EG1, EG2 and CG. Scheffe test results from Table 11 reveals that there was significance difference among the three groups (EG1, EG2 & CG). Thus, EG1 is significantly better and enhanced retention ability than EG2, while EG2 enhanced retention ability than control group in acquiring skills in biology. Therefore, the stated null hypothesis was rejected. This finding corroborates with the findings of Olarewaju (2012), Kadala (2014) and Mohammed (2019). They stressed that studies on retention and instructional strategies seem to agree with selection of suitable instructional strategies that are characterized by active learning or actions that are activity based such as project-based approach which yields permanent and meaningful learning that is readily retained and remembered at will by the learner.

Table 5 result reveals that the mean performance scores of male students are higher than the mean performance scores of female students after exposure to Project-based approach in biology. This agreed with the null hypothesis that states that there is no significant difference in the performance mean score between male and female students when exposed to project-based approach, thereby retained. The corresponding null hypothesis was answered in table 12 using ANOVA and the results reveals that there is no significant difference on the performance mean score between male and female students after exposure to Project-based Approach in Biology. This finding agreed with the work carried out by Mohammed (2019), the entrepreneurship skills acquisition which states that gender has no significant difference on the extent of entrepreneurship skills acquisition using designed project and demonstration method. This implies that the use of the three different teaching approaches had no interactive effect on sex difference in terms of students' performance in biology concepts for entrepreneurship. The null hypothesis was hereby retained.

The results from Table 6 reveals that in EG1 the mean score of students after exposure to DATS as assessment tool (formative) in evaluating the level of skills acquisition is higher than those students exposed to TFLE and shows that students acquired Moderate Skills. The result agreed with the finding of Mohammed (2019). ANOVA was used to test for the significant difference and the result presented in table 14 reveals that there is significant difference in students' ability level in skills acquisition using DATS as assessment tool and TFLE as assessment tool of Project-based approach. The null hypothesis was hereby rejected. The Post



Hoc Scheffe test results from table 15 reveals that there is significance difference among the three groups with, EG1 significantly better in enhancing students' ability level than EG2, while EG2 enhanced students' ability level in skills acquisition than CG among SS2 students in biology. The use of Project-based approach using DATS as assessment tool showed significant difference in students' ability levels in skills acquisition better than TFLE as assessment tools of Project-based approach. This is supported by the work carried out by Mohammed (2019), Nwagbo and Chekelu (2011) and Cakici and Turkmen (2013).

### **Conclusion**

This study was undertaken to investigate the Impact of Project Based Strategy on Students Retention and Performance in Biology Concept for Entrepreneurial Skills Acquisition Among Secondary School in Zaria, Kaduna State. Based on the findings of this work, it is pertinent to conclude that; students perform better in Biology concept when taught using Project Based Strategy when compared to their counterpart taught using a traditional teaching method. Also, the study shows that Project-based Strategy is effective in promoting students retention ability in biology also Students' retention ability in acquisition of skills is enhanced when exposed to Project-based Strategy ;there is no difference in the performance between male and female students taught using Project Based Strategy that shows that the treatment is gender friendly and finally Students' ability levels in entrepreneurial skills acquisition using DATS as assessment tool was better than those exposed to TFLE as assessment tools of Project-based Strategy.

### **Recommendations**

Based on the findings of this study, the following recommendations were made:

1. Project-based approach using diagnostic adaptive testing skill (DATS) should be adopted in the teaching of biology concepts for entrepreneurship among senior secondary school students.
2. The text book publishers should develop suitable training manuals and work books that will enhance effective delivery of biology concept for entrepreneurship through Project-based Strategy using DATS among secondary school students.
3. Project exhibition of finished products should be encouraged in schools as it develops in students' occupational knowledge, job skills, work experience, and this makes self-employment and business ownership a viable and appealing goals for today's students.

### **References**

- Agbenyeku, G. A. (2020). Science technology education in secondary schools: Neds For Manpower Development. *Journal of Science Teachers Association of Nigeria*, (28)2.
- Agbeyeku, P. (2010). Effect of advance organization performance and retention in ecology concepts among senior secondary school in Giwa, Educational Zone. A.B.U., Zaria. Unpublished Med Science Education Thesis.



- Agbeyeku, P. (2010). Effect of advance organization performance and retention in ecology concepts among senior secondary school in Giwa, Educational Zone. A.B.U., Zaria. Unpublished Med Science Education Thesis
- Ajala, A. O., Ogunjimi, S. I., Famuwagun, O. S. & Adebimpe, A. T. (2021). Poultry production in Nigeria: exploiting its potentials for rural youth empowerment and entrepreneurship *Nig. J. Anim. Prod.*, 48(1), 114–123.
- Anfafuwa, P. A. O. (2017). The instructional method on retention of biological concepts. *Nigerian Educational Forum*, 11(1), 79-82.
- Arogundade, B. B. (2011). Entrepreneurship education: An imperative for sustainable development in Nigeria. *Journal of Emerging Trends in Educational Research and Policy Studies*(JETERAPS), 2(1) 26-29.
- Atsuwe, B. A & Anyebe, E. N. (2016). Effect of generative instructional strategy on senior secondary school students' performance in Otukpo Local Government Area of Benue State. *International Journal for Social Studies*, 2(5), 41-48.
- Bello, G., Alabi, H. I., Ahmed, A. R., Sulaiman, M, M., Bello, Z. A. & Bello, A. A. (2020). Biology education and bio entrepreneur opportunities in Nigeria Nigerian. *Online Journal of Educational Sciences and Technology (NOJEST)*, 1(2), 1 – 17.
- Cakici, Y. & Turkmen, N. (2013). An investigation of the effect of project-based learning approach on children's achievement and attitude in science, Trakya University, Edirne Turkey. *The Online Journal of Science and Technology (TOJSAT)*, 1(1)8-17.
- Dennis, E. J., Paul, B. P. & Inyang, I. S. (2021). Effect of simulation method on students' academic performance and attitude towards entrepreneurship education among public secondary schools in Uyo Local Government Area. *World Journal of Interactive Research (WJIR)*, 4(1).
- Eita, I. & Ashipla, K. (2020). Strategies of developing entrepreneurial skill in biology education: Teacher factors. *Science Teachers Association of Nigeria (STAN) Annual Conference, HEBN, Ibadan* 123.
- Fenton, R. Manuel, R. & Mukundu, C. (2013). Project approach as an alternative to regular laboratory practical work in the teaching and learning of biology in rural secondary school in Zimbabwe. *International Journal of Education and Information Studies Research Indian Publication*, 1(1), 13-20.
- Kadala, J. T. (2014). Effect of concept mapping and project-based instructional strategies on junior secondary school students' performance and attitude towards geometry in Adamawa state Nigeria, *PhD. Thesis* ABU Zaria, Nigeria.

- Kajuru, Y. K. (2015). The role of mathematics in promoting and sustenance of entrepreneurship education for voluntary agencies, organizations and institute in Africa. *Lead Papers Proceedings of African Conference*, ABU, Zaria.
- Malilima, M. Z. (2019). The Pre- service teachers' awareness of bio-entrepreneurial skills opportunities in biology as a means of economic development (A Study of Some Selected Colleges of Education in Borno State, Nigeria). *International Journal of Strategic Research in Education, Technology and Humanities*, 6(2).
- Mohammed, I. B. (2019). Effects of project-based approach on acquisition of entrepreneurial skills, retention and performance in biology among secondary school students in Niger State, Nigeria. Unpublished Thesis of Doctor of Philosophy Submitted to Faculty of Education, Ahmadu Bello University, Zaria, Nigeria.
- NTI(2001). General methods in education PGE by DLS, NTIPDE 103, Kaduna 54-110.
- Nwagbo, K. & Chikelu, I. (2019). Enriching senior secondary school biology curriculum through integrating entrepreneurship activities. In STAN 50<sup>TH</sup> Annual conference, HERBN, Ibadan 128-129.
- Obialor, C. O., Osuafor, A. M. & Nnadi, E. I. (2017). Effect of project work on secondary school student's science process skills acquisition in biology, Nnamdi Azikiwe University, Awka, Nigeria, *JORIND* 15(1), 371-378.
- Oghenevwede, O. E. (2022). *Developing entrepreneurial skills in biology education: A necessary tool for poverty alleviation*. Research Gate.
- Oghounu, A. E. (2015). Vocational guidance as tool for entrepreneurship development in senior secondary students in Nigeria. *Delta Business Education Journal*, 5(1), 58-64.
- Okafor, C. F. & Nwanaka, A. (2022). Job creation in post-covid era: Role of biology education towards employability and global competitiveness. *COOU Journal of Educational Research*, 7(1), 376-389.
- Olarewaju, F. R. (2012). Effects of cooperative learning strategies with models on academic achievement, retention of biology concepts among pre-national diploma students in Kaduna, State, Nigeria ABU Zaria *Unpublished Thesis*.
- Rao, V. V. & Sri, D. P. (2019). The role of entrepreneurship education in nurturing the potential entrepreneurs to fuel the economic growth engine. *International Journal of Business Management & Research (IJBMR)*, 9(1), 13-22.
- SMASE (2010). Strengthening mathematics and science education, Baseline Handout Cycle I, JICA, FGN Nigeria 1-30.
- Ugbaja, Y. (2012). How to transfer Nigeria education system, 34 Daily Sun, March 13th, 2012.



## Factors Mitigating Against Women Participation in Computer Science in Borno State

<sup>1</sup>Ojo Oluwasesan Adebusuyi, <sup>2</sup>Abdullahi Abdulfatai Oluwashina,  
<sup>3</sup>Aji abdulmumini & <sup>4</sup>Itodo Andrew

<sup>1</sup>Department of Computer Science, <sup>2</sup>Department of Economics, <sup>3</sup>Centre for Human Resource Development,  
<sup>4</sup>Department of Computer Science  
Umar Ibn Ibrahim El-kanemi College of Education, Science and Technology,  
Bama, Borno State

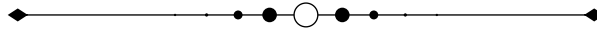

### **Abstract**

*Women's "second class" position in our society necessitated their struggle for equality with men to enable them survive in this changing society. Western education has influenced some traditional practices of our society, so much that the traditional ties of domestic responsibilities such as running the homes do not bind the modern women. The development of science and technology can make men and women to become self-reliant and less dependent and enable them to contribute meaningfully to the nation building. The paper examines the concept of computer science; the access of women to computer science; the role of computer science knowledge in nation building; and the factors mitigating against the active involvement of women in computer science. Recommendations were suggested: government should provide the necessary facilities needed for the programme; Religious and Community leaders should educate their members about the important of girl-child(women) education in the family and nation building.; They should also be enlightened about gender equality in the society so that the preference of males over females should be eliminated; In order to improve on the enrolment of female children into school, government should emphasis on the laws and policies that prohibit the removal of female children from school and early/forced marriage. So that they (women) can be equally represented with their male counter parts in the discipline.*

**Keywords:** *Participation, Western education, Facilities, Nation building, Computer science*

---

## **Introduction**

The world has witnessed two major revolutions, viz: the industrial revolution and the information revolution. The information revolution has the greatest impact and caused the most dramatic change in the development of the human race. Computer science have been the major vehicles of change in the transition from the industrial revolution to the information age. In order to keep pace with the changes brought about by the information revolution, it is necessary to be familiar with the machine called computer. According to Fisusi (2001) Computer is any device capable of accepting data automatically applying a sequence of processes to the data and supplying the results of these processes. Scott (1993) defined computer, as a modern digital device that is largely comprises a collection of electronic switches, these switches are used to represent as well as control the routing of data elements called binary digits (bit). He stressed further that the technology age in which we are now living is characterized by increasing use of computer system. This act is being experienced in various areas of human endeavours. For instance, computer found extensive application in business financing engineering, health, education, domestic, shares national development etc. Inferring from the above definition and uses of computer therefore, women participation in computer science is still at its lowest ebb.

## **The Concept of Computer Science and Education**

Computer Science is one of the veritable disciplines necessary for national development in the modern world. For any country to develop fast, her citizenry needs to be computer literate. Computer as put forward by Johnson (1985) is an information-processing machine. It is a device, which enables the user to process information. It captures, process and store information (Roger, 1996). Ayeni sees computer as a modern electronic machine, which is used for performing simple or complex processes. It is also seen, as an electronic device that uses instructions provided to it which is stored in its memory. Computer is an electronic machine that can best be described as a powerful device which has the capacity to accept data as input, apply a series of arithmetical and logical operations on the data, and produce the results of these operations as an output information at a very fast speed(Olatunji, 1998). From the description above, a computer can be regarded as an input-process-output system.

Education on the other hand is a means of positive change of individual perception of himself and others, which contribute meaningfully to the development of the society. Education as defined by Umar and Gbana (2003) is a tool used in equipping the individual with the skills and knowledge, which helps in societal transformation. It is the greatest investment that a nation can provide to her citizens for the development of her natural and human resources. From the above discussion therefore, education can be regarded as the head cornerstone for effective nation building. Computer education is that type of education given to the citizens of a country whether males or females, at all levels of learning. So that they can fully participate in social, economic, political and technological development of their country. Computer education is the imparting of computer knowledge and skills for effective development in different spheres of life (Chinyere, 2001).

## **The Access of Women to Computer Education**

The level of development of any nation depends much more on the level of literacy of her citizen. Education is a birth right and not a privilege of every citizen of Nigeria irrespective of gender disparity (Richard & John, 2002). Women just like their men counterparts need

computer science so that they can play effective role in nation building. Women as observed by Ayanniyi (1999) are group of people who constitute valuable resources of talent and energy who need to be given sound education to enable them contribute their potentials in the societal transformation, and improve their family's socio-economic status (Umar & Ghana, 2003). In line with this, the constitution of 1979 of the Federal Republic of Nigeria and the National Policy on education (1998) stress the right of women to education. This boosted the moral and status of women not in small measure. Many women aspired academically and they are serving in various capacities in various disciplines, ministries, parastatals and organisations. Just like these women, many other women who aspire in computer science are presently serving in different capacity across the country. Such women among others include Adu Adeponle Olubukola of citizen bank Lagos; Adeyasa Tolulope Olubukola of mobil oil company Warri; Alo Opeyemi Grace of software development company Lagos; and Kolapo Esther Yetunde-accountant in equity bank Lagos (Faculty of Science Bulletin, 1996-1999). Despite all these developments, the number of women in computer education is still below expectation especially when compared with their male counterparts. Most women in Nigeria particularly in Northeast are not computer literate and therefore, cannot contribute their potentials to the development of the country IT wisely (Chinyere, 2001).

### **The Role of Computer Science in Nation Building**

It would be arduous, if it is impossible to enumerate the areas in which computer science's knowledge are applied. Computer is used in various situations to influence the lives and activities of man. In business for example, computers are used for their accurate and performance in calculations as found in banking insurance, commercial business and other related financial sectors. With the use of computers, which have capacity for information storage, managers have access to relevant accurate and timely information. Banks use computers in their daily routine jobs, which include electronic transfer in banking system. This enable banks check credit balance of any of their customers in another branch of the bank located far away from the customer branch (Fisusi,2001). Computers are used in military to develop weapons and defence systems. The Scud and anti-scud missiles as asserted by Omozuwa (2004) are all computers-controlled equipment. Computers are also used to check invasion of air space by unauthorized aircraft. This is achieved by computer-controlled radar. Computers are also used in health industries. Computers are used for medical diagnosis and test of patients' sample. Computer aided topography scanner as observed by Fisusi (2001) help medical doctors to take several pictures of the body organs, and this can be used for diagnosis. Patients' records in the hospitals are no more manual files. They are now all stored on hard disk or in storage devices for future references. Lately, computer aided scanners are being used to monitor pregnancies.

Another field of endeavour that uses computer is the communication industry. In media communication, both print and electronic media have been greatly influenced by computers. In print media, the computerized printing and publishing machines have raised the standard of journalism since they have access to information from wide area of coverage in the shortest possible time. The transport section of the communication sector particularly air transport as noted by Omozuma (2004) now use computerized air traffic control system which has replaced the mechanical calculating instruments. Small computers are now part of the planes equipment to give timely information to pilots and flight engineers. Another important discipline which cannot be left out from the application of computer is education industry.



Computers have influenced almost all subjects in school. Computers are used as tools (Computer-assisted learning) to assist in learning and instructions. Educational materials such as textbooks can be downloaded through internets and read online or printed through printers. In administrative unit staff and students' records are stored in computers (Fisusi, 2001). Other areas that use computers include police, prison, immigration, customs and many others. The negative impact of computer is reserved to be a subject of other studies. In spite of these enormous contributions of computer, women are still under-represented in the field, why? This takes us to the constraints that hamper the participation of women in computer science.

### **Factors Mitigating Against the Active Involvement of Women in Computer Science**

Many factors inhibit the level of women participation in computer science. One of such factors as observed by Chinyere (2001) is lack of physical facilities. Most schools do not have computer laboratory where the practical aspects of computer can be taught. Where they are available, they are not enough. Other factors are hereby stated below:

#### **Societal Perception**

The way the society perceives women influences their enrolment into science and technology. According to Okorie (2000), women as a group in Nigeria are perceived to be weak, less intelligent, irrational and passive. This negative perception on women can deprive them of certain opportunities like formal education and active enrolment into computer science courses. He further stated that because of socialization, men are assigned jobs which involved physical strains, logical thinking and competition.

#### **Parental preference for Male Children**

Another factor that militates against women enrolment into computer science is the preference of male children over female ones. Most people see no reason in sending their daughters to school. In situation of scarce financial resources in the family, many parents prefer to educate only the male children (Chinene, 2004). Majority of the people in Nigeria as revealed in the study carried out by UNICEF (2001) live below poverty line with high proportion in the North and in the rural areas. Most families cannot afford to educate all their children. As a result, only one or two children are sent to school. If choice is to be made with regard to who will go to school between a male and a female child, boys are usually preferred. All these and many other factors affect the enrolment of females into computer science studied.

#### **Gender Discrimination**

Ogwuazor (1992), is of the opinion that science has been given a masculine image, culturally, science is seen as meant for males while females who pursue science courses are seen as over-ambitious individual who are competing with males as well as deviants who are independent, arrogant and over sophisticated. This explains why men dominate such professions like computer science, carpentry, building and automobile mechanics.

#### **The Ignorance of the Parents**

Another limiting factor is that of ignorance of some parents to let their female children be enlightened educationally. Some parents tend to believe that science and technology education entails the exhibition of physical strengths which are not found in women and



therefore, strictly restrict science and technology to men alone. In view of this, Ogwuazor (1992), discovered and cited in her study that parental attitude towards male and female children constitutes a great barrier to women's participation in science and technology in Nigeria. In view of the above assertion, the deprivation of female child by parents to pursue educational carriers can be attributed to parental attitude to ignorance and the consequence of illiteracy.

### **Religion and Culture**

In some societies, religious and traditional practices do not allow women to engage in certain activities or professions that expose certain parts of their bodies, hence, such activities that expose their bodies are strongly discouraged. It is because of this reason that only few women join and participate in science and technological based courses (Okorie, 2000).

### **Inadequate Human Resources**

Lack of teachers is another constraint to women in computer science according to (Chinyere, 2001).

### **Early Child Marriage**

The cultural practice of early child marriage especially in the Northeast sub-region of the country as observed by UNICEF (2001) and Richard and John (2001) affect the number of females in schools and in computer science subject in particular. Most parents in the sub-region give out their daughters in marriage when they are too young for their consent to be sought. Most of those who are opportune to go to school are withdrawn for the same purpose. Another major impediment that affect woman participation in computer science is lack of instructional facilities. Most schools that have computer department do not have the necessary software-hardware which are used in the teaching of computer (Chinyere,2001). Most of them teach only the theoretical aspect of the course since there is no enough instructional facilities in schools where a few computers are available the tendency is for the boys to become domineering and possibly bully the girls hardly have access to the machine.

### **Recommendations**

As discussed above, the contribution of computer science in nation building is of paramount importance. To alleviate the obstacles that hinder women from having access to computer science studies, the following recommendations are given:

1. The government (public schools) and the proprietors/proprietaries of private schools should make sure that qualified teachers and necessary physical facilities needed for the teaching and learning of computer should be made available
2. The computer hardware themselves together with their accessories should be put in place before the take-off of the programme
3. In order to improve on the enrolment of female children into school, government should emphasis on the laws and policies that prohibit the removal of female children from school and early forced marriage. Any parent found wanting with regard to this law should be seriously sanctioned
4. Religious and Community leaders should educate their members about the importance of girl-child (women) education in the family and nation building
5. They should also be enlightened about gender equality in the society so that the preference of males over females should be eliminated

6. The impact of the government also should not be left out by providing the necessary facilities needed for the programme
7. Computer teachers in schools where the physical facilities are available should ensure that they pay equal attention to boys and girls while giving instruction. They should ensure that girls also have equal access to the machine and opportunities for practice
8. Women should not be bound by stringent cultural and traditional practices; they should be allowed to participate fully and actively in science and technological courses
9. The parents and general public should be educated and enlightened so as to bring about a change in attitude towards women educational programmes
10. The career officers and counsellors should be appointed in schools so as to guide male and female students on their course's careers
11. Women participation in computer science course should be encouraged by way of giving loans, rewards, prizes and scholarship to the interested candidates
12. Females, who show interest and commitment in computer science should be recognised and to act as role models for the female's gender to arouse their interest etc.
13. For the fact that women need to be self-reliant, empowerment to participate and contribute meaningfully to all forms of nationally development, there is need for serious attention to women education especially in the area of computer science course

### **Conclusion**

The paper discussed the concept of computer education and the access of women to computer science studies, which is regarded as the steering wheel for national development. We have also seen the role of computer in nation building. The paper also discussed some factors that prevent women from being having access to computer science studies. This includes the preference of males' education over that of females by some parents and lack of instructional materials and poverty. As a result, therefore, some recommendations are given to eliminate the obstacles so that they (women) can contribute effectively in the family up-keep and in moving the nation to greater heights. Therefore, the researchers put forward that women should not be restricted to the kitchen and taking care of children alone, instead should be encouraged to participate in other aspect of life that contributes to national development especially such as an area of computer science.

### **References**

- Ayanniji, R. B. (1999). Women education and cultural practices: Towards socio-economics development in JOWICE 3.
- Ayeni, J. O. (1992). *Fundamentals of computing*. University of Lagos, Nigeria: University of Lagos Press.
- Chinene, J. A. (2004). Analysis of street hawking in North Eastern Nigeria. In A. Fajoyomi,(ed). *A Journal of Educational studies*, 7.

- Chinyere, O. A. (2001). Early childhood education in computer: The role of women in Nigeria. In N. P. M. Esomonu (ed). *Journal of Women in Colleges of Education*.
- Fisusi, R. Z. (1990). *Computer fundamental: An introductory course Nigeria*. Ganny International Limited.
- Faculty of Science Bulletins (1996-1999). University of Ilorin. Okorie, J. U. (2000). *Developing Nigeria's workforce*. Calabar: Macnky Environs Publishers.
- Ogwuazor, K. E. (1992). Nigerian women and science education. The situation so far. *A Journal of Science Education Izanikan*, 1(1).
- Olatunji, E. K. (1998). *Introductory system programming Nigeria*. Igbagbobi Publication Limited.
- Omozuwa, F. A. (2004). The role of computer in education. Editor in chief. *Akoka Journal of Vocational Education*, 3(1).
- Richard, A. O. O. & John, E. O. (2002). Education of the Nigerian women: A tool for effective child up-bringing. In O. R. Elado (ed). *Ekiadolor Journal of Education*, 6(1).
- Rogers, C. (1996). *Information technology* (2<sup>nd</sup> ed). New Delhi: Martin the Printer Limited.
- Scott, M. (1993). *Upgrading and repairing personal computer* (3<sup>rd</sup> ed). Indianapolis: David P. Ewing.
- Umar, M. H. & Gbana, N. S. H. (2003). Educating girls: An investment for the future. Being a paper at the 8<sup>th</sup> Annual National Conference of Women in Colleges of Education held at F.C.E Yola,, Adamawa State. 14-17<sup>th</sup> October 2003.
- UNICEF (2001). *Children's and women's rights in Nigeria: A wake-up call*. Nigeria: National Planning Commission Abuja and UNICEF.



## Effect of Deferred Tax Accounting on Financial Performance of Manufacturing Companies in Nigeria

**Okafor Victor Ikechukwu**  
Department of Accounting  
Michael Okpara University of Agriculture, Umudike



### *Abstract*

*The study examined the effect of deferred tax accounting on financial performance of listed manufacturing companies in Nigeria using data from 19 out of 56 listed manufacturing companies that are selected based on judgmental sampling technique. In so doing, the study adopts the Vector Error Correction Model (VECM) to test two hypotheses stated in line with the specific objectives. Findings from the study reveal that, deferred tax asset and liability have a positive but insignificant effect on profitability of listed manufacturing companies in Nigeria. Following the study's findings, the study suggests that manufacturing enterprises in Nigeria investigate possible tax credits for specific assets and investigate the feasibility of utilizing such tax credits to minimize their tax burden through tax deferral. This may minimize the enterprise's tax burden and, as a result, boost the firm's profitability.*

**Keywords:** *Deferred tax assets, Deferred tax liability, Tax accounting, Financial performance, Manufacturing companies*

---

### **Introduction**

Finding strategies to reduce a company's overall tax liability is one of the most pressing responsibilities of a corporate tax manager (Abiola, James, & Asiweh, 2012). According to theories, a firm's tax burden is proportionally tied to its profitability; achieving the firm's wealth maximization goal through various means of growing profitability imposes greater challenges on the firm's ability to lower its tax liability. Deferred tax, according to Savka and Radojko (2013), is a part of successful tax planning and methods that maximize the firm's

predicted discounted after-tax cash flows. Aside from being well-versed in tax legislation, any company's tax advisors should have a thorough understanding of the company, its history, and how the organization operates to predict its deferred tax liability (John, Samuel & Holy, 2013). According to Chlodik (2011), deferred tax temporary differences may also include both time gaps applied in the final accounting records and differences that have not passed through the comprehensive income statement because deferred tax is not actually in the true sense but a projection of what is likely to occur. This deferred tax forecast, as claimed by Nwaorgu, Abianhu, Tapang, and Iormbagah (2019), will limit the distribution of profit parts that were not subject to owing income tax to funds formed from profit or among shareholders in the present period. This is a significant issue that arises when firms account for deferred tax. There is no doubt in accounting theory about the necessity of deferred tax when formulating tax plans, the goal of which is to correct the impact of due income tax on company profitability (Citron, 2014). According to Ogundajo and Onakoya (2016), the concept and content of deferred tax have a certain history, development, and experience in Nigeria; nonetheless, it cannot be argued that in its practicality it is a self-evident and cohesive part of current financial report. According to Ogundajo and Onakoya (2016), even though deferred tax first appeared in Nigerian firms' accounting reports in the early 1990s, it became more well-known to the professional accountant's audience when Nigeria adopted the International Accounting Standard Board's financial reporting standards (IASB). Since then, all accounting companies that are required to prepare financial statements in the full format have been required to account for deferred tax. This was the beginning of deferred tax accounting methodology in Nigeria, as deferred tax accounting reduces accounting profit or loss distortions caused by the effect of deferring tax circumstances for the addition of accounting expenses or revenues to the income tax base (Ogundajo & Onakoya, 2016).

The theories and practices of implementing an all-deferred tax in a firm's tax plan cannot be overstated; hence, additional research on the topic of deferred tax, including deferred tax assets and their effect on company profitability, particularly from a Nigerian viewpoint, is required. The goal of this study is to emphasize the complexities, as well as the larger context, surrounding the requirement of corporations using deferred tax procedures. Therefore, this study will examine the effect of deferred tax on the financial performance of manufacturing companies in Nigeria. The specific objectives of the study are to:

- i. assess the effect of deferred tax assets on the profitability of listed manufacturing companies in Nigeria.
- ii. ascertain the effect of deferred tax liability on the profitability of listed manufacturing companies in Nigeria.

## **Review of Related Literature**

### **Concept of Deferred Tax**

The value of the deferred tax, as defined by International Accounting Standard (IAS) 12, is the amount of income tax due for payment in a future period in connection with taxable transitory differences. According to Halim, Veysel, and Baykut (2015), the deferred tax might include both deferred tax assets and liabilities. According to David (2003), the liability part of deferred tax is the money generated for accounting purposes rather than tax ones. According to David (2003), deferred tax obligation identifies future taxes owed when generated income is later recorded for tax reasons. One of the primary reasons a company lists deferred income taxes as a liability on its statement of financial position is the use of accelerated depreciation for filing



to the Revenue authorities and straight-line depreciation for reporting to stockholders (Goh, Lee, Lim & Shevlin, 2013). Deferred tax is a tax that a corporation will owe on its income but has not yet been assessed in its financial statements (Halim et al., 2015). According to Chang, Herbohn, and Tutticci (2009), deferred tax is a financial reporting construct. According to Burgstahler, Elliott, and Hanlon (2002), a deferred tax asset is a projected future tax saving tied to book income that represents temporary changes in cash flow timing. Burgstahler, Elliott, and Hanlon (2002) went on to say that a deferred tax asset is created when an expense is deductible for calculating book income in the current period but not for tax reasons until some future period when income is includible in present taxable income but not in book income until some future period, or when carry forwards exist. Compensation-related expenses (e.g., retiree health insurance, stock options, and defined benefit), other accrued expenses (e.g., guarantee expenses), asset impairments (e.g., intangible assets, inventory write-offs), and the company's net loss and tax credit carryforwards are examples of deferred tax items. Deferred tax liability is the projected future tax rise on book income (Nwaorgu et al., 2019). When an expense is deductible for tax reasons in the present period but not for book income till some future date, or when revenue is includible for accounting purposes yet does not constitute taxable income until some future period, a deferred tax liability is established (Bauman & Shaw, 2016). According to Barth, Beaver, and Landsman, (1998), a common deferred tax liability component includes book-tax depreciation differences (accelerated for tax purposes), instalment sales, and undistributed or reinvested earnings.

On the statement of financial status, most companies declare simply the net deferred tax assets as well as deferred tax liabilities (Nwaorgu et al., 2019). If the net deferred tax assets exceed the net deferred tax obligation, the firm reports a net deferred tax asset; if it exceeds the net deferred tax liability, the firm reports a net deferred tax liability. Because of this opinionated accounting for deferred tax, the report of deferred tax components varies greatly across enterprises subject to managerial judgment (Haskins & Simko, 2011). To keep the statement of financial position current, Statement of Financial Accounting Standard 109 requires a yearly calculation of the deferred tax assets (including the valuation allowance) and deferred tax obligation. The valuation allowance must be created if it is more likely than not that some portion or all of the deferred tax assets will not be realized (FASB 109). Deferred tax expense is generally affected by the reporting of and changes in deferred taxes. Nonetheless, changes in deferred taxes are directly reflected in equity, implying that they are income neutral. If the underlying transaction or event that results in the book-tax difference is reported as a separate profit or loss (IAS 12.58). Deferred tax obligations often result from financially recorded income that has not yet been taxed, such as in the instance of accelerated tax depreciation, in which tax liability is deferred into the future by accelerated depreciation rates that exceed book depreciation values. Deferred tax assets, on the other hand, often originate as a result of earlier expensing for financial accounting purposes than for tax purposes (Weber, 2009). In his assessment of IAS 12, Rohaya, Nor'Azam, and Bardai (2010) argued that deferred tax components can indicate book-tax differences that occur naturally due to differences in tax legislation vs accounting standards, as well as book-tax differences that inform about book-tax choices. Deferred tax assets, on the other hand, coming from book-tax discrepancies in pension provisions, for example, imply that corporations often employ a lower discount rate in calculating the pension provision for book reasons than for tax purposes (Purina, 2016).

However, because the presence of unused tax losses and tax credits, as well as a recent history



of losses, may indicate that future taxable profit is not accessible (IAS 12), IAS 12 provides additional guidance on the reporting of deferred tax assets for tax loss and tax credit carryforwards. When calculating the likely utilizable share of unused tax losses and tax credits, an entity should take into account the availability of reversing deferred tax liabilities, projected future taxable income, the sources of the unutilized tax losses, and available tax planning strategies, according to IAS 12. Deferred taxes are measured at the tax rates that are projected to apply when the underlying asset or liability is realized or settled since they represent future tax consequences. However, because future tax rates are unknown, current tax rates, i.e., tax rates and tax legislation implemented or substantively enacted by the end of the reporting period, are used for measurement (IAS 12).

### **Financial Performance**

According to Berger and Patti (2002), business performance is typically measured by ratios derived from income statements or stock market prices, also including industry-adjusted operating profits or stock market returns. This is consistent with Pandey's (1995) argument that profit maximization results in the optimum allocation of resources in a market that is competitive, and profit is seen as the most relevant measure of a firm's performance. Hill and Jones (2009) and Girish, Harsh, and Nidhi (2014) agree that profitability is the most important indicator of a company's financial performance. Hence, financial performance ratios in this context focus on the link between profit and sales as well as profit and assets utilized (Ilaboya, Izevbekhai & Ohiokha, 2016). Return on assets is calculated by dividing earnings after tax by total assets. Companies with more steady cash flows are more profitable, and they prefer to use debt since they have greater debt servicing capacity and higher tax profit (Myers, 2001). Similarly, profitable enterprises with free cash flows should benefit from loans to meet their needs and should not misuse free cash flow to preserve firm liquidity (Modigliani & Miller, 1963). Jens and Schweltnus (2008) empirically demonstrated a negative association between write-offs and profitability, however, the introduction of deferred tax assets has changed this assumption.

### **The Ability to Pay Theory**

This research is based on Adams Smith's ability to pay theory, which he proposed in 1776. According to Adams Smith's (1776) ability-to-pay approach, taxes are levied depending on taxpayers' ability to pay. Taxes are viewed as a sacrifice by taxpayers (individuals and businesses), raising the question of what each taxpayer's sacrifice should be and how it should be quantified. The ability to pay hypothesis is argued to stem from the premise that corporations in forming their tax plans take into account the available firm resources, which range from the profit made, asset structure, and tax incentives/ credits. With due consideration to these resources, firms determine the most effective tax rates pay at the moment and the taxes to be deferred. Nwaorgu et al., (2019) argued that it posits the firms' resources and consequently ability to pay taxes.

### **Empirical Review**

Quite several investigations had been conducted on the interrelationship between deferred tax and the financial performance of firms in developed and developing countries in recent times. Nwaorgu et al., (2019); Uwuigbe, (2016); Mayeenda, (2013); Ogundajo and Onakoya, (2016); Gatsi, Gadzo and Kportorgbi, (2013); Akinyomi and Tasie, (2011) all studied an aspect of deferred tax and how it affects the financial performance of companies. They mostly focused

on deferred tax liability. The various arguments by authors and application of standards have created a source for the future application of effective tax planning in the form of a deferred tax considering only deferred tax liabilities. These studies from Africa do not take into account the deferred tax asset that is exceptionally accounted for provided that there is a sufficiently high tax base in the future against which this asset could be applied. Meiryani, Fernando, Hendratno, Dewiyanti, and Yanny (2021) researched the impact of deferred tax charges on earnings management in banking firms. This study makes use of secondary data derived from financial reports or annual reports of companies registered on the Indonesia Stock Exchange. Their data analysis method is linear regression analysis. Their findings indicated that deferred tax expenditure had an impact on earnings management.

Mear, Bradbury, and Hooks (2020) evaluated the value relevance of recognized deferred tax elements under International Accounting Standard 12 (IAS 12): Income Taxes (balance sheet method) to taxes payable (flow-through). They also look into the worthiness of IAS 12 deferred tax disclosures. Their analysis employed typical valuation models to investigate the relationship between share price and IAS 12 recognized amounts and footnote disclosures. The Vuong (1989) test is then applied to determine which information set is more valuable. The sample comprises 440 firm years from 2008 to 2012. The findings reveal that deferred tax amounts recognized using the balance sheet technique give no more information to investors than deferred tax amounts recognized using the taxes payable approach (TPM). Deferred tax footnote disclosures, however, are more relevant than the amounts recognised under the balance sheet method.

### Methodology

The ex post facto research approach is used in this study. This study's population consists of 56 manufacturing companies that are listed on the Nigerian Exchange Group as of July 2021. The study used the judgmental sampling technique to choose 19 companies as the study's sample size. These are the companies that were listed throughout the study period and have complete data in their financial reports. Extracted data from the sampled firms audited financial statements are rigorously analyzed, and pertinent data from the period 2015-2020 is extracted for analysis. To investigate the relationship between the dependent and independent variables, the multiple regression methodology employing the ordinary least square regression (OLS) method is used.

This study formulates the following model to be used by the researcher in the investigation with some modifications of the model by Nwaorgu et al., (2019);

$$ROA_{it} = \alpha + \beta_1 LOGDTA_{it} + \beta_2 LOGDTL_{it} + U_{it} \dots \dots \dots Model 4$$

Where;

$\alpha$  = Constant

ROA = Return on assets

LOGDTA = Log of Deferred Tax Asset

LOGDTL = Log of Deferred Tax Liability

IT= Cross-section (i) at a time (t)

U = Error term used in the model.

$\beta$  = beta coefficient of the independent variable.

**Decision Rule:** Accept the null hypothesis if the calculated value is greater than the significant

level of 0.05.

## Results and Discussions

### Descriptive Statistics

The descriptive statistics for both the dependent and independent variables are presented in Table 1.

	LOGDTA	LOGDTL	ROA	LEV	EPS
Mean	5.577517	5.629476	0.085747	0.324172	1.626667
Maximum	7.807889	7.874419	0.459459	0.991418	9.760000
Minimum	3.710202	3.079904	0.002969	0.003143	0.020000
Std. Dev.	1.035834	1.003555	0.093432	0.251884	2.092950
Skewness	0.240609	-0.115852	1.875356	0.846643	2.022782
Observations	114	114	114	114	114

Source: E-View Output

Table 4.1 presents the descriptive statistics of all the variables. N represents the number of observations and therefore the number of observations for the study is 114. The result reveals that, deferred tax asset (LOGDTA) reflects a mean of 0.5.577517 with a deviation of 1.035834. LOGDTA also revealed a maximum value of 7.807889 and a minimum value of 3.710202. Also, deferred tax liability (LOGDTL) reflects a mean of 0.5.629476 with a deviation of 1.003555. LOGDTL also revealed a maximum value of 7.874419 and a minimum value of 3.079904. The return on asset (ROA) has a mean of 0.085747 with a deviation of 0.093432. Furthermore, ROA records a maximum and minimum value of 0.459459 and 0.002969. Result also reveals that, leverage (LEV) reflects a mean of 0.324172 with a deviation of 0.251884. LEV also revealed a maximum value of 0.991418 and a minimum value of 0.003143. Earnings per share (EPS) reveal a mean of 1.626667 with a deviation of 2.092950. EPS further revealed a maximum and minimum value of 9.760000 and 0.020000 respectively.

The Skewness statistic is used to test for data normalcy. The skewness to standard error ratio can be used to determine normalcy. The data set for all variables reveals skewness statistic values ranging between about -2 and +2. This suggests that the data are not too much out of whack from the mean to produce non-normality difficulties.

### Diagnostic Test

This section of the study presents in the multicollinearity test using correlation matrix and the test for stationarity using both the unit root and co-integration tests.

**Table 2: Correlation matrix**

	LOGDTA	LOGDTL
LOGDTA	1	
LOGDTL	0.6809	1

Source: E-View Output

Table 2 shows the correlation values of all the variables to ensure the test for multicollinearity of the independent variable since they consist of unranked data. The correlation matrix above shows the absence of multicollinearity among the explanatory variables as all the variables

show a low correlation estimated at 0.6809 (LOGDTA & LOGDTL).

### Stationarity Test

To further prove the normality of data and to ensure that the data set are stationary in order not to run a spurious regression, unit root test is carried out to ensure that the variables employed in this study are stationary at same unit before further analysis.

**Table 3: Unit Root**

Variable	LLC (Common P-value)	ADF (Individual P-Value)	Order	Difference
LOGDTA	0.0000	0.0115	I(0)	LEVEL
LOGDTL	0.0000	0.0023	I(0)	LEVEL
ROA	0.0000	0.0024	I(1)	1 <sup>st</sup>

**Null: There is serial Unit Root in the data**

*Source: E-view Output*

The table above shows the result of the first test required to know the common and individual stationarity of the variables. For the common stationarity test, the Levin Lin Chu (LLC) test for common stationarity is used which considers lags in data series. Result for the study model (ROA = f (LOGDTA & LOGDTL)) revealed a unit root result for LLC and ADF P-values of less than 0.05 for LOGDTA and LOGDTL which depicts common and individual stationarity at level, while ROA has common and individual unit root after 1<sup>st</sup> differencing. This means that, there is need for cointegration test in order to determine whether the study will adopt an error correction model for long run adjustment.

### Co-integration Test

**H<sub>0</sub>:** There is no co-integration

**Table 4: Co-integration**

S/N	Statistic	Model ROA
1	Panel v-Statistic Within Dimension	4/11

*Source: E\_views Output*

In the ROA model, there are eleven test statistics. Out of the 11 cointegration test statistics, 4 of the statistics have probability values of <0.05; that is less than 6 statistics. Therefore, the model reveals that, there is no cointegration of data in the longrun. Therefore, the error correction model is adopted for further analysis.

### Estimated Model Summary

Table 5 presents the results produced by the five model summaries for further analysis;

**Table 5: Error correction model**

Long run equilibrium	Coefficient	Short run equilibrium	Coefficient
ROA (-1)	1.0000	ROA (-1)	-0.025574
LOGDTA (-1)	0.145372	LOGDTA (-1)	0.010945
LOGDTL (-1)	-0.127751	LOGDTL (-1)	0.000779
ConET	-0.149439	Const	-0.174068

*Source: E-View Output*

Table 5 present result of the Vector Error Correction Model (VECM) for LOGDTA, LOGDTL and ROA to test for long run and short run shocks correction as a result of non-cointegration of the data set in the model. The various coefficient values of the short run equilibrium are compared against the long run equilibrium to ascertain the level of bounce backs in addressing non long run cointegration issues of the model.

After differencing, the adjustment coefficient (ConET) value of -0.149439 shows that, the previous period deviation from long run equilibrium is corrected in the short run at an adjustment speed of 0.149439. For ROA coefficient, a unit change in ROA is associated with a -0.025574 unit decrease in ROA in the short run *Ceteris Paribus* against the long run coefficient of 1.0000. For LOGDTA coefficient, a unit change in LOGDTA is associated with a 0.010945 unit increase in LOGDTA in the short run *Ceteris Paribus* against the long run coefficient of 0.145372. For LOGDTL coefficient, a unit change in LOGDTL is associated with a 0.000779 unit increase in LOGDTL in the short run *Ceteris Paribus* against the long run coefficient of -0.127751.

**Table 6: Panel error correction model regression**

VAR Variable	Coefficient	Probability	Statistic	Value
ROA (C2)	-0.025574		R <sup>2</sup>	0.059
LOGDTA (C3)	0.010945	0.6521	R <sup>2</sup> Adjusted	0.006
LOGDTL (C4)	0.000779	0.9786	Fisher Statistic	1.120133
			F Probability	0.353925
Constant (C5)	0.003667	0.6578	DW	1.779404

Source: E-View Output

To ensure that the set of data was free from serial auto-correlation the Durbin Watson statistic for the model specified is computed. The Durbin Watson statistics for the model specified is estimated at 1.779404. The Durbin Watson statistics for the series data is within the standard of 2 indicating the absence of auto-correlation. The Durbin Watson statistics ensures that the residuals of the proceeding and succeeding sets of data do not affect each other to cause the problem of auto-correlation. Thus, this model exhibit low risk of potential autocorrelation problem as the model shows a DW statistics of approximately 2.

For model fitness, the R<sup>2</sup> value is used to establish the level of overall fluctuation the study independent variables (LOGDTA & LOGDTL) can collectively cause ROA as the dependent variable to change. The R square value of approximately 0.059 shows that LOGDTA and LOGDTL cause ROA to fluctuate at approximately 5.9%; this means that 94.1% fluctuation of the return on assets of listed firms is caused by other factors not considered in this study like; actual tax paid. The R<sup>2</sup> adjusted value of approximately 0.006 revealed shows that, there will be a 0.053 (0.059 – 0.006) variation from the sampled result of R square if the other omitted factors are considered. This means that if the amount of tax paid for the firms are considered, there will be either 5.3% increase or decrease in the level of fluctuation deferred tax accounting can cause ROA to change. The Fisher statistic reveals a value of 1.120133 with a probability value of 0.353925 which prove that the overall model is statistically insignificant.

The constant value of 0.003667 revealed shows that, if all the independent variables are held constant; the ROA of the firms will increase by 0.003667 units. Furthermore, a unit change in



LOGDTA will cause ROA to increase by 1.09%, also a unit change in LOGDTL will cause ROA to increase by 0.07%

***HO<sub>1</sub>: Deferred tax asset has no significant effect on return on assets of listed manufacturing companies in Nigeria.***

Since the calculated probability value for LOGDTA (0.6521) against ROA is greater than the accepted probability value of 0.05. The null hypothesis is accepted and the alternative rejected thus; deferred tax asset has no significant effect on return on assets of listed manufacturing firms in Nigeria.

***HO<sub>2</sub>: Deferred tax liability has no significant effect on return on assets of listed manufacturing companies in Nigeria.***

Since the calculated probability value for LOGDTL (0.9786) against ROA is greater than the accepted probability value of 0.05. The null hypothesis is accepted and the alternative rejected thus; deferred tax liability has no significant effect on return on assets of listed manufacturing firms in Nigeria.

### **Discussion of Result**

In terms of the hypotheses investigated, the findings demonstrated that deferred tax assets and liabilities have no substantial effect on the return on assets of Nigerian-listed manufacturing companies. The study's findings contrast those of Nwaorgu et al. (2019), who investigated the impact of deferred tax accounting on the financial performance of Nigerian-listed agricultural companies. They used information from four publicly traded agricultural corporations. They discovered that deferred tax accounting had a favourable and significant association with listed enterprises' profitability. The variation in the industry that both studies focused on, as well as the method utilized in determining deferred tax by both studies, is the source of this disagreement. While, Nwaorgu et al., (2019) focused on an agricultural firm that enjoys more tax credits that lead to huge net deferred tax assets, firms in other sectors are not given many tax credits compared to the agricultural sector; thus, the variation in finding is eminent.

### **Conclusion and Recommendation**

Based on the findings of this study and the testing of the two research hypotheses earlier formulated in the study, the study concludes that deferred tax assets and liabilities have a positive but insignificant effect on the return on assets of listed manufacturing firms in Nigeria. Following the study's findings, the study suggests that manufacturing enterprises in Nigeria investigate possible tax credits for specific assets and investigate the feasibility of utilizing such tax credits to minimize their tax burden through tax deferment. This may minimize the enterprise's tax burden and, as a result, boost the firm's profitability.



## References

- Abiola, O., James, A. & Asiweh, M. (2012). Impact of tax administration on government revenue in a developing economy: A case study of Nigeria. *International Journal of Business and Social Science*, 8(8), 234-246.
- Adam, S. (1776). *An inquiry into the nature and causes of the wealth of nations*. Edited by Edwin Cannan.
- Akinyomi, O. & Tasie, C. (2011). The impact of tax incentives on the performance of small and medium scale enterprises in Adamawa State. *Universal Journal of Accounting and Research*, 1, 183-188.
- Barth, M., Beaver, W. & Landsman, W. (1998). Relative valuation roles of equity book value and net income as a function of financial health. *Journal of Accounting and Economics*, 25(1), 1-34.
- Bauman, M. & Shaw, K. (2016). Balance sheet classification and the valuation of deferred taxes. *Research in Accounting Regulation*, 28(2), 77-85.
- Berger, T. & Di Patti, B. (2002). Capital structure and firm performance: A new approach to testing agency theory and an application to the banking industry. Feds Paper No. 2002-54.
- Burgstahler, D., Elliott, B. & Hanlon, M. (2002). How firms avoid losses: Evidence of use of the net deferred tax asset account. Working Paper SSRN.
- Chang, C., Herbohn, K. & Tutticci, I. (2009). Markets perception of deferred tax accruals. *Accounting and Finance*, 49(4), 645-673.
- Chludek, A. (2011). Perceived versus actual cash flow implications of deferred taxes: An analysis of value relevance and reversal under IFRS. *Journal of International Accounting Research*, 10(1), 1-25.
- Citron, D. (2001). The valuation of deferred taxation: Evidence from the UK partial provision approach. *Journal of Business Finance & Accounting*, 28(7&8), 821-852.
- David, L. (2003). *An A to Z guide to investment terms for today's investor*. Houghton Mifflin Harcourt, Boston's Financial District, United States.
- Financial Accounting Standards Board (1992). Statement of financial accounting standards no. 109: Accounting for income taxes.
- Gatsi, J., Gadzo, S. & Kportorgbi, H. (2013). The effect of corporate income tax on financial performance of listed manufacturing firms in Ghana. *Research Journal of Finance and Accounting*, 4(15), 118-124.

- Girish, K., Harsh, P. & Nidhi, C. (2014). Influence of Risk Management on Performance of firms. *Journal of Accounting and Financial Management*, 4(4), 156-170.
- Goh, B., Lee, J., Lim, C. & Shevlin, T. (2013). The effect of corporate tax avoidance on the cost of equity. European Accounting Association Annual Congress. Research Collection School of Accountancy.
- Halim, S., Veysel, K. & Baykut, E. (2015). A research on deferred taxes: A case study of bist listed banks in Turkey. *European Journal of Business and Management*, 7(2), 1-9.
- Hanlon, M. (2005). The persistence and pricing of earnings, accruals, and cash flows when firms have large book-tax differences. *Accounting Review*, 80, 137-166.
- Haskins, M. & Simko, P. (2011). What a corporate tax cut might mean: An analysis of deferred taxes. Working paper.
- Hill, C. & Jones, G. (2009). *Theory of strategic management with case*: 8th edition. Australia: South Western Cengage Learning.
- Ilaboya, O., Izevbekhai, M. & Ohiokha, F. (2016). Tax planning and firm value: A review of literatures. *Business and Management Research*, 2(5), 267-285.
- Jens, A. & Schweltnus, C. (2008). Do corporate income taxes reduce productivity and investment at the firm level. Cross-country evidence from the amadeus dataset.
- John, G., Samuel, G. & Holy, K. (2013). The effect of corporate income tax on financial performance of listed manufacturing firms in Ghana. *Research Journal of Finance and Accounting*, 4(15), 118-124.
- Mayeenda, S. (2013). The effect of tax incentive on firm performance: Evidence from Uganda. *Journal of Politics and Law*, 6(4), 95-107.
- Mear, B. & Hooks, I. (2020). Is the balance sheet method of deferred tax informative? *Pacific Accounting Review*, 32(1), 23-34.
- Meiryani, F., Hendratno, D. & Yanny, P. (2021). The effect of deferred tax expense on earnings management in banking companies. ICEBA 2021: 2021 7th International Conference on E-Business and Applications Sejong Singapore.
- Myers, S. (2001). Capital structure. *The Journal of Economic Perspectives*, 15(2), 81-102.
- Modigliani, F. & Miller, M. (1963). A correlation between corporate income taxes and the cost of capital. *American Economic Review*, 53(3), 433-443.
- Nwaorgu, I., Abianhu, M., Arzizeh, T. & Iormbagah, J. (2019). Effect of defrred tax accounting on financial performance of listed firms in Nigeria. *Social Science Research Network*.

- Ogundajo, G. & Onakoya, A. (2016). Tax planning and financial performance of Nigerian manufacturing companies. *International Journal of Advance Academic Research*, 2(7) 64-80.
- Pandey, I. M. (1995). *Essentials of management accounting*. New Delhi; Vikas publishing House PVT Ltd.
- Purina, M. (2016). Deferred tax under IAS 12 in the chosen Czech and Russian companies. *Procedia – Social and Behavioral Science*, 220(1),382–390.
- Rohaya, M., Nor'Azam, M. & Bardai, S. (2010). Corporate tax planning: A study on corporate effective tax rates of Malaysian Listed Companies. *International Journal of Trade, Economics and Finance*, 1(2), 1-5.
- Savka, K. & Radojko, T. (2013). Analysis of deferred taxes in the business environment in Serbia. *Economic Serbian Management Journal*, 16(1), 25-37.
- Uwugbe, U. (2016). Tax incentive and the growth of manufacturing firms in Nigeria. *Medwell Journal*, 11(7), 1338-1342.
- Weber, D. (2009). Do analysts and investors fully appreciate the implications of book-tax differences for future earnings? *Contemporary Accounting Research*, 26(4), 1175– 1206.



## A CONTRASTIVE STUDY OF LEXICAL FIELD OF FOODS IN ENGLISH AND JUKUN (WĀPĀN) LANGUAGES

<sup>1</sup>Ajiduku, Beavens Ahmadu & <sup>2</sup>Ishaya, Yusuf Tsojon  
<sup>1&2</sup>Department of English and Literary Studies  
Taraba State University, Jalingo

---

### *Abstract*

*This study is a contrastive analysis of lexical fields of foods in English and Jukun languages. English is a non-African language of the Germanic family of languages while, the Jukun language is an African language of the Nigritic or Niger-Congo family. They are, therefore, not related genetically. Specifically, the study investigates the similarities and differences between English and Jukun languages for the purpose of effective teaching and learning. The research focused lexical fields of foods. The data were gathered through oral interviews. Twenty adult native speakers (10 males and 10 females) of Jukun language were interviewed. The study adopted the Prototype theory (Lobner, 2002; Charlie 2013; Crystal 2008)) which is basically concerned with categorizations used for typical members of the extension of a referent. The theory was used to explain the categorization of foods in the two languages. Findings of the research revealed several similarities and differences. It revealed that although food is a universal phenomenon, yet geographical factors and other factors such as weather, religion, tradition, can influence the type of food found in a particular society. Jukun has corresponding names for the foods that are familiar to them but lack names for those that are absent in their environment. The study was aimed at providing teaching and learning materials for the Jukun teacher of English as a second language.*

**Keywords:** *Categorization, Genetically, Germanic, Niger-Congo, Prototype.*

---

### **Background to the Study**

English language is not only the official language of Nigeria, it is the language of the media, of politics, commerce, communication, international transactions, it is also the language of

education. Because it is a language of education native speakers of various Nigerian languages (including the Jukun native speakers) are expected to learn it. Most Nigerian users of language lack a proper knowledge of the grammar or meaning of some lexical items in their languages. This can be partially blamed on some teachers of English as a second language (L2) who often neglect certain features of some lexical items. This situation has made some language users not to be properly grounded in the knowledge and meaning of some lexical terms in English. Essien (2003) supports this view by stating that the English used by many Nigerians of younger generation may have English words and expressions but little grammar and meaning. He goes on to state that several suggestions on how to remedy this situation have been explored by some language experts yet the conceptualization and expression of the ideas and thoughts of English language users in this generation keep getting poorer. This study is a contrastive study of the lexical field of food terms in English and Jukun languages. The study is carried out with the view that the data gathered from the two languages would help the Jukun teacher of English and the Jukun learner of English a better understanding of the various lexical.

### **Statement of the Research Problem**

English is the official language of Nigeria which every Nigerian is expected to learn in school in order to attain certain standards in the country. Adegbite (2010) posits that the early stage of learning English as a second language in Nigeria is the contrastive and error analysis stage. However, it appears that the earlier studies in contrastive analysis have focused only on some of the 'major' languages in Nigeria with little or no attention on the 'minority' languages. Due to the position English occupies today in Nigeria, it is expected that citizens ought to attain certain levels of mastery of the English language for better communication. The Jukun learner of English as a second language (L2), is not an exception because he or she needs to learn English too. A knowledge of certain lexical fields and the lexico-semantic features of English and Jukun would help in this regard. As Filani (2013) observes, one of the challenges mitigating against the proper use of English among some Nigerians is the poor mastery of English lexical items especially the lexico-semantic fields of culinary, kinship, foods, etc. It is necessary, therefore, to do a contrastive study of some lexical fields in English and Jukun to bring out their similarities and differences and to highlight the difficulties that may arise in the process of teaching and learning. Doing so will help to give an insight into the semantic features of the lexical fields and also help to provide some teaching materials for effective teaching and learning of the target language which is English.

### **Theoretical Framework: Prototype Theory**

Prototype theory has its origin from cognitive semantics. The fundamental idea of cognitive science is that of categorization. The idea behind the prototype theory is that people are assumed to categorize ideas and concepts in their minds such that after a perceptual system acquires information about an entity in the environment, the cognitive system places the entity into a category. The prototype theory, in the view of Charlie (2013), is concerned with how natural categories are not characterizable in terms of necessary and sufficient conditions but are graded (fuzzy in their boundaries) and inconsistent as to the status of their constitutional members. Systems of categories are not objectively "out there" in the world but are rooted in people's experience (207). The theory, as suggested by Crystal (2008), is basically concerned with categorizations used for typical members of the extension of a referent. In this view, for example, a sparrow would be a prototype of the categorization of birds, whereas an ostrich

(because of its typical characteristics of inability to fly) would not be a prototype of bird. Prototype semantics has to do with the development of criteria for the definition of prototypical meanings, with specific reference to how the radial set of overlapping meanings interrelate, and the nature of category membership and boundaries (395).

Below is the characterization of the prototype model as suggested by Lobner (2002)

- i. Graded structure: Membership of a category are of unequal status.
- ii. Prototypes are best examples. Certain prototype members are consistently regarded as the best examples of the category.
- iii. No set of necessary conditions. Category membership is not a matter of a fixed set of necessary conditions. Prototypes of a given category can be explained by some properties which are absent with less typical examples.
- iv. Family resemblance. Members of categories are related by family resemblance.
- v. Prototypes are reference points. Prototypes serve as reference points for categorization because categorization is a matter of similarity to the prototype.
- vi. Graded membership. Categorization of membership is a matter of degree.
- vii. Fuzzy boundaries. Categories are characterized by fuzzy boundaries.

Prototypes contain two important properties: first, they are usually the best among their category. This is due to the graded structure of categories stated earlier. Conversely, this existence of best examples, alongside good examples, entails a graded structure. Prototypes also serve as reference points for categorization. Meanwhile, the two properties are considered mutually dependent. Prototypes are the best examples because they serve as reference points and they are able to do so because they are the best examples. Similarity itself is a matter of degree. The second property of prototypes implies graded membership. Category is not a yes-or-no matter of degree. Therefore, as a consequence of graded membership, categories have fuzzy boundaries. Fuzzy boundaries are understood to give rise to graded structure: the clear members of a category are better members than those which form the fuzzy boundary area of the category. Graded structure and graded members are regarded as essentially two sides of the same coin. If an item is a poorer member, it is less similar to the prototype and hence belongs to the category to a lesser degree and vice-versa (179)

### **Methodology**

The research was limited to semantic field of foods in English and Jukun languages. For the data presented, field research was undertaken, 20 adult native speakers of Jukun (10 males and 10 females) were interviewed. The participants were people who acquired the Jukun language as their first language. The data collected was further validated by members of the Jukun Language Literature committee (JLLT). The researcher also relied on his and his knowledge of the English language and his intuition as a native speaker of the Jukun language to explain some of the information gathered.

### **Linguistic Universalism/ Relativism; Semantic Universals**

The debate between language universalism and linguistic relativity has been raging on for quite some time. The idea of language universals is generally regarded by linguists as certain linguistic properties found across natural languages. Fromkin, Rodman & Hyams (2011: 298) lend credence to this view where they posit that universal rules that hold in all languages and those rules representing the universal properties common to all languages which constitute a



universal grammar. A linguistic universal is seen by linguists as a pattern which is traceable and occurs systematically across natural languages of the world. For example, all languages are said to possess nouns and verbs. However, if a language is spoken, it is said to have consonants and vowels (Crystal, 1995). But linguists such as Nicolas, Evans & Levinson (2009) have opposed the existence of absolute linguistic universals believed to run through languages of the world. They pointed out problems such as ethnocentrism as well as inadequate research into all of the languages of the world and went ahead to promote the similarities as only strong tendencies.

Linguistic relativity or Sapir –Whorf Hypothesis was developed by Edward Sapir and his student, Benjamin Lee Worf and his student who conducted research on the Hopi language in order to establish the relationship between language, thought and perception. They discovered that Hopi does not have the equivalence of the concept of 'time', 'space' and also do not mark tense in their grammar as most languages of the world. They concluded that humans adjust to reality through the language they speak, therefore, humans are at the mercy of the language they speak. That is, humans dissect nature along lines dictated by their languages. In other words, language determines man's thoughts. This is otherwise called linguistic determinism. The hypothesis posits that the structure of a language can influence a speaker's worldview or cognition, therefore, one's language can determine or shape his or her thoughts or worldview. For instance, different words mean different various things in other languages because it is not every word in all languages that have a one-on-one translation in another language. Our culture is shaped by the values, norms and beliefs of our society. The language we create, and use happens to be a reaction to the cultural and societal needs as they arose. In other words, the way talks and the way we perceive the world are somehow related in a way (Frothingham, 2023). This view was later challenged by other linguists who pointed out that language does not determine our thoughts but that it only reflects our environment and our experiences. This paper agrees that humans are not trapped by language but that humans use language to express what is found in their environment as well as their experiences in that environment. Human beings can therefore understand concepts that do not exist in their experience and can also use their language to encode such concepts. The relevance of the Sapir-Worf Hypothesis in contrastive analysis, especially in the comparison of lexical items, in the view of Filani (2013), is that it gives an insight into how each language lexicalizes different items in each field. This can easily be traced to the environment of the second language learner and his/her experiences. It also helps to reveal that the learner is not entrapped by his or her language, but only utilizes it to express what he/she experiences. It also helps to reveal that what is not in the language learner's language but found in the target language can be conceptualized and understood by the learner.

Semantic universals on the other hand, refer to properties of meaning which are shared by all natural languages. Those properties that are universal are believed to be easier to learn while those that are not are said to be hard to learn. Filani (2013) opines that Semanticists are interested in the idea of semantic universals, that is universality of semantic features and whether they occur in all languages or not. He concludes that it is proper to maintain that language reflects the culture and experience of its speakers and hence semantic features and words in a semantic field are bound to differ across languages and this is what gives credence for the comparison of semantic fields across languages. In language teaching therefore, it should be noted that words that exist in a language learner's first language often reflect the

culture and experience of the learner and so since semantic fields are universal, the words that do not exist in the learner's first language can still be comprehended by the learner with the appropriate method which is by comparing the lexical words.

### **Contrastive Analysis (C.A); An Overview**

Contrastive analysis (or CA) is a term mostly used in Applied Linguistics and it is the systematic comparison of more than one language with the sole aim of describing their similarities and differences. The major aim is to provide better description and better teaching materials for language learners. It is also referred to as a systematic study of a pair of languages with a view to identifying their structural differences and similarities.

Richards & Schmidt (2012) see Contrastive Analysis as having to do with the comparison of the linguistic systems of two languages, for example, the sound system or the grammatical system. Similarly, Crystal (2008) sees it as a general approach to the investigation of language which is Contrastive Linguistics. It is carried out in certain areas of Applied Linguistics. The approach is based on the following assumptions:

- I. That major difficulties in learning a new language are caused by interference from the first language.
- ii. That the difficulties can be predicted by using a contrastive analysis
- iii. That teaching materials can make use of contrastive analysis to reduce the effects of interference.

Bammer (1992), argues that among the major problems confronting learners or users of a second language is the 'tyranny of mother tongue'. In his opinion, the need to tackle the problem of mother tongue interference in second language usage is what gave rise to what is now known as contrastive analysis or contrastive linguistics. He views Contrastive Analysis as the juxtaposition of certain aspects of a pair of languages such as the native language (L1) and the target language (L2) with the aim of identifying those areas that are similar and those that are different in order to predict areas of difficulty so as to design remedial teaching and learning strategies in those areas. While the similarities can aid to facilitate the learning process, the differences usually can lead to interference or negative transfer in the learning process.

Bammer's (1992), position agrees with that of Bamgbose (1996) and that of Banjo (1970) who posit that contrastive analysts base their arguments on the grounds that the possible areas of difficulty for the second or foreign language learner could be predicted and therefore emphasized in order to ensure proficiency. It is the duty of the instructor to study the nature of and structure of the two languages, compare and contrast them for the purpose of predicting the errors the language learner may likely commit (p.103).

### **Food Categorizations in English and JUKUN**

Food is regarded as substance consumed for the nutritional support for any living organism. Food is usually got from plants, fungi which contain vital nutrients, such as, carbohydrates, proteins, vitamins, fats or minerals. It is a basic necessity of life, and it exists in every human society. The historical narrative of food is as old as man and it plays a very important role in the various cultures and societies of the world. Food experts have categorized food into (i) vegetables and fruits (ii) grains, legumes, nuts and seeds (iii) meat and poultry (iv) fish and

seafood (v) diary food (vi) eggs, etc. (Leafy place, 2019). Aside from other categorizations food can be categorized into some sets such as Cereals, Roots, Vegetables and Stimulants. Cereal is the superordinate term for the sets of foods such as barley, buckwheat, maize, millet, oats, rice, rye, wheat. Root, on the other hand, is the head of all foods whose roots are harvested from tubers. Such foods, for instance, include yam, cocoa yam, water yam, potato, cassava, etc. vegetable heads the group of leaves, stalks, fruits, nuts, and seeds, etc. stimulants are the foods that behave as chemical agents or drugs that help to invigorate or add certain functional activity of the body. Most time, stimulants are combinations of several chemicals which may be cooked or uncooked. Such foods do not really provide nourishment to the body as others but they serve as stimulants. For instance, caffeine or theine in coffee, kola nut, and tea leaves; nicotine in tobacco, alcohol in wine or beer. All these serve as stimulants to the human body. The last grouping of foods above are common or familiar to the two languages. These categories and the way they are realized in the two languages are presented in the table below:

### Representation of Some Food Items in English and Jukun

FOODS							
Roots ( <i>ādēnhīn/āpā</i> )		Vegetables ( <i>ājèbū/ānwābū</i> )		Cereals ( <i>āngyībū</i> )		Stimulants ( <i>ājān báá wāwā</i> )	
ENGLISH	JUKUN	ENGLISH	JUKUN	ENGLISH	JUKUN	ENGLISH	JUKUN
Yam	<i>āsí</i>	Spinach	–	Barley	–	coffee	–
Cassava	<i>āhīnmbù</i>	Lettuce	--	Bambara nuts	<i>āfyè</i>	tea	–
Potatoes	<i>keúdākū</i>	Cucumber	–	Oat	–	tobacco	<i>Pítábā</i>
Cocoa yam	<i>ātún</i>	Carrot	–	Groundnut	<i>Fyèkèn</i>	wine	–
Water yam	<i>agbòn</i>	Pumpkin	–	Wheat	–	beer	<i>āchēn</i>
Carrot	–	Grape	–	Maize	<i>āzākpà</i>	–	<i>pitó</i>
Groundnut	<i>fyèkèn</i>	–	<i>Ábó</i>	Beans	<i>āsò</i>	–	<i>àzù</i>
Bambara nut	<i>āfyè</i>	Sorrel	<i>āwi</i>	Millet	<i>āzā jimi</i>	–	<i>wūchēn</i>
–	<i>ātèn</i>	Okro	<i>ādón</i>	guinea corn	<i>āzā jikwìn</i>	–	<i>tómtóm</i>
–	<i>agbù</i>	Pepper	<i>āshítá</i>	beneseed	<i>ādò</i>	–	<i>āfù</i>
		Cabbage	–	archer	–	Brandy	–
		Apple	–	–	<i>Áshì</i>	Spirit	–
		– Garden egg	<i>byòsò</i> <i>Áfyè</i>	Rice	<i>ngyibyēn</i>	champagne	–

It can be noted that in the table, some of the English food items do not have their corresponding terms in Jukun and vice versa. Most of the food items that have been introduced into the Jukun society for a long period of time, e.g. yam, cassava, water yam, cocoa yam, etc. have all been renamed or described according to how the Jukun people understand them. There are those that do not have corresponding names in Jukun therefore their English names have been slightly moderated in Jukun such as *atea* (tea), *awine* (wine), *abeer* (beer), *abrandy* (brandy), etc. There are some that are actually not corresponding names in Jukun but rather descriptive terms for the food items. For instance, *āhīnmbù* (cassava) is a descriptive term meaning 'tree that produces whitish flour', *āshítá* is a descriptive term referring to the reaction (*sss/š*) one produces after eating a hot, peppered meal, *fyèkèn* is also a descriptive term which means 'grains of war'. Also there are some that are not known completely to the Jukun such as buckwheat, barley, oat rye, etc. This clearly indicates that some of the items are only prevalent among the English people and other European countries. Even though some

may have managed to find their ways to the Jukun environment, there is a sense in which we can say that they are majorly of English or European origin. For example, the terms in the cereal group like barley, buckwheat, oats, rye, e.tc. are purely of English or European foods.

### Food Terms in JUKUN

Jukun language has several names for specific types of foods or stimulants which are cultivated and consumed by them in their environment. The language classifies certain group of foods along the dimension close to that of English such as *Ādēnhīn* (root foods) *Ānwāhīn* (fruits) and *Jēbū* (vegetables leaves) and *Āngyì* (seeds or cereals). From this classification, it can be observed that such foods in the language are categorized in accordance to the parts that are edible or consumed by the people. Certain foods in Jukun are members of some larger classes. The Jukun people are traditionally farmers and one of the most commonly cultivated families of crop in Jukun land is the grains (*āngyibū*) family. A popular grain crop in Jukun society is the *āzā* sub-group. We therefore draw the tree diagram of the hypernym *āngyibū* thus:

### A Taxonomy of Food Classes and there in Jukun and English

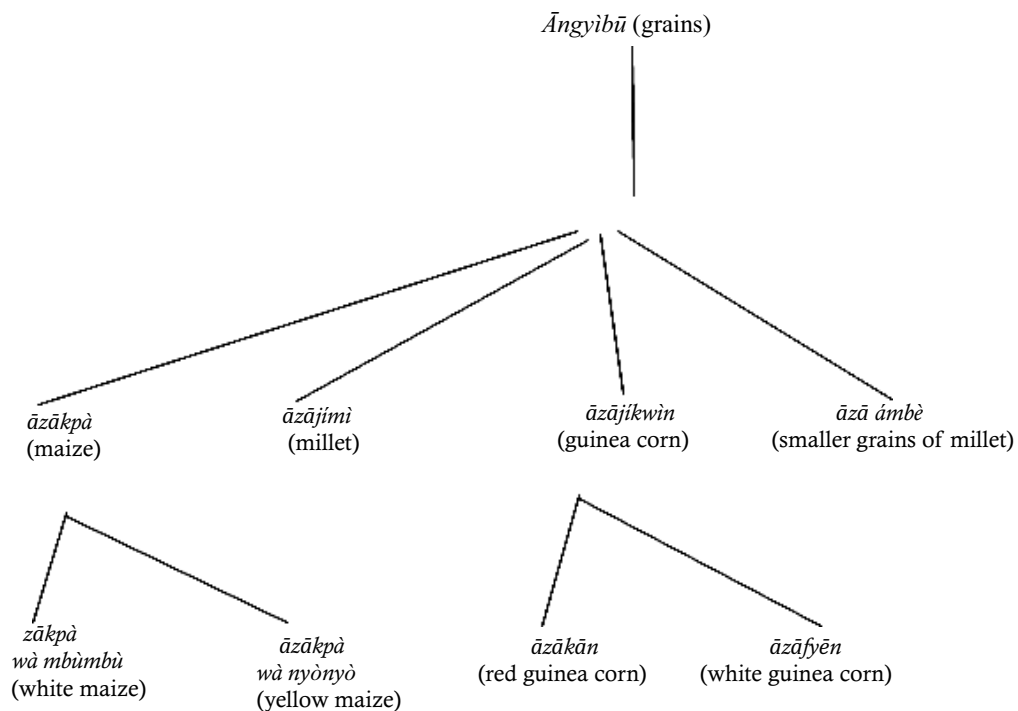

## A Taxonomy of Cassava in Jukun and their Prototypes

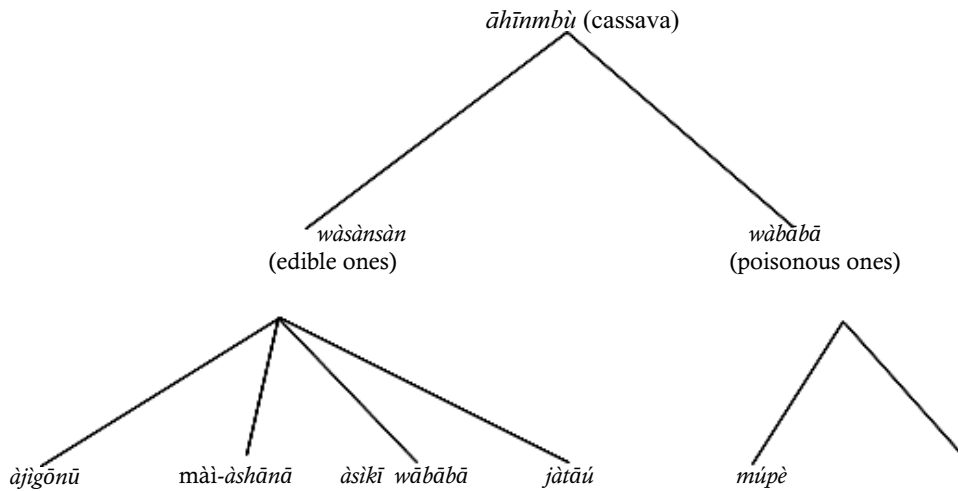

*Mūpè* is believed to be very acidic and when not properly processed or is eaten raw can lead to death. On the other hand, *àjìgōnū* and *àsìkì* can be eaten raw even when not processed. The terms '*màì-àshānā*' and '*jàtāú*' are borrowed terms from Hausa language to refer to those types of cassava which have now been fully domesticated in the Jukun society.

### Differences in Food Terms in English and Jukun

A basic fact about food is that each society names those it cultivates and consumes. This is so especially that the culture and the geographical environment of a people play vital roles in determining the types of food in any human society. Other factors such as weather, religious belief, tradition also have huge influence on the type of food found in particular societies. From the foods listed so far, it can be seen that in many cases we cannot provide equivalent items for either Jukun or English for example, cereal crops like barley, wheat, buckwheat, oats, there appear to be no equivalent terms. This is also applicable to some vegetable terms like spinach, lettuce, cabbage, cucumber and carrots. Stimulants such as coffee, tea, caffeine, wine are also absent in Jukun language while some cereal crops like *àshì* (a *peppery* seed used in cooking) is also absent in English. Among root crops, a particular item in Jukun environment known as *ātèn* and *āgbù* are also absent in English. Also, other vegetable leaves like *ābó*, *āwì*, *byòsò*, may not have their equivalents in English.

### Contrastive Statement

As a result of these facts above, the physical realities of the food types in English will pose learning problems because the Jukun learner of English may not be able to conceptualize some of the English foods because they do not exist in their environment. Besides some food items in English fall into more than one category. For instance, carrot falls under the category roots and vegetable, while groundnut, Bambara nut, all fall under the category of roots at the same time they fall under the category of grains. This different categorization may cause a problem of conceptualization. Also, as it appears, although vegetables like lettuce, cucumber, cabbage, carrot may not be new to some learners. It is possible that such learners may find it challenging to describe them in a composition exercise. Also, except for tobacco, Jukun



language has no equivalent terms for tea, coffee, cocoa, therefore, the learner may be tempted to use the term 'tea' as a cover term for all the beverages listed above.

### Similarities in Food Terms in English and JUKUN

Both English and Jukun have specific ways of categorizing foods found in their immediate environments. The two languages do not only use food terms for lexical or denotative purposes, but they also use such terms for connotative or metaphorical purposes with some specific meanings attached to them. The mere fact that food remains a basic necessity to human life on earth attests to the fact that food is a universal phenomenon. Even though types of foods may differ from culture to culture or from society to society, each society may categorize food into groups such as cereal, root, vegetable, stimulant, e.tc, among others.

It can be seen that some entries of food items in English are totally absent in Jukun society and vice versa. A basic universal fact remains that in each case in the two languages, the absent categories can be supplied through one of the following linguistic processes. Butari (2010) suggests the following as some of the ways to solve the absent of some categories in a language.

- I. Coinage: In any human language, there is always a room to coin words for new terms in the language. For example, in Jukun language, foods such as rice (*āngyìbyēn*), *āsí* (yam), *kúdākú* (potato) etc. are known to be terms which were coined into the language in order to refer to them because they are alien to Jukun food domain.
- ii. Borrowing: Borrowing is a universal linguistic occurrence which human societies can exploit to enrich their vocabularies. This could be done by borrowing from a neighboring language or languages, regional lingua franca or from a foreign language such as English. Some of these perceived empty entries could be filled up using such lexemes from other languages. For example, food items such as *āléyàhō* (African spinach), *jógólé* (moringa leaf), are borrowed from Hausa language and *búrédì* (bread), carrot, tea, coffee are borrowed from English into Jukun language.
- iii. Description: Some of the empty entries in the table could be supplied through the use of descriptive terms. For example, in English, terms such as Irish Potatoes, Guinea corn, Palm tree, Groundnut, are descriptive in nature. *Āfyèkēn* (nuts (eaten) in times of war), *āfyè gbānkpó* (nut with hard seed) *ābyòsò* (beans leaf), *ājè nàsārā* (the leaf of the Whiteman) which is used for cooking vegetable soup are all descriptive. The same principle can be used to provide the terms for the empty slots for the English terms that are not found in Jukun.

### Lexical Relations in Food Terms in English and Jukun

The terms yam, cassava, potatoes, carrots, etc. are hyponyms of the prototypes 'roots', while terms like spinach, lettuce, cabbage, apple, etc. are hyponyms of the prototypes, vegetables. Carrot shares some of its characteristics with the roots family even though it is also a part of the vegetable family. Also, grapes, apples, etc. even though are vegetables they are fruits as well in English. Terms like barley, buckwheat, oats, millet, archer, are categorised under the prototype class of cereals yet they are also seen as grains.

In Jukun, the hyponyms of the superordinate term *ādēnhīn* (roots) are *āsí* (yam), *āhīnmbù* (cassava), *àgbòn* (water yam), *ātún* (cocoa yam). *Ānwā* (vegetables) as a superordinate term has *ābó* (a vegetable leaf used for draw soup), *àwì* (a vegetable leaf), *àdòn* (okro), *āshítá* (pepper), *byòsò* (vegetable leaf). *Āngyì* (cereals) is a polysemous term with *āngyì* (grains) and *āngyí*



(electric fish) in Jukun but it is also a superordinate term for the hyponyms *āzānkpà* (maize), *āsò* (beans), *āzā jímí* (millet), *ā̀dò* (beneseed), etc. while terms like *pītábá* (tobacco), *āchēn* (beer), *pító* (a local wine), *wūchēn* (a locally brewed non-alcoholic drink), *tōmtōm* (a locally brewed non-alcoholic drink) and *āfù* (porridge) are classified under *ājàn báá wáwā* (stimulants). *Pītábá* (tobacco) shares certain characteristics with the family of leaves which makes it to be a bit different from the others which are considered as drinks in general.

The terms *āfyè* and *áfyē* and *āfyè* are homographs in Jukun language. While *āfyè* refers Bambara nuts, *áfyē* refers to garden eggs and kidney. Another pair of homographs is *wābābā* and *wàbàbà*. These are also homographic terms which are hyponyms of *āhīnmbù* (cassava) in Jukun. The first term *wābābā* refers to a poisonous sub-class of cassava while *wàbàbà* (a type of cassava that produces many tubers) forms a taxonomic sisterhood with the terms *ājìgōnū*, *màìashānā* and *āsikī* in the taxonomy of the superordinate term *āhīnmbù* (cassava) in Jukun. Aside from the primary functions of food terms to humans as a means for the sustenance of livelihood on the planet, certain terms for food items are also manipulated for the sake of communication. Below are some examples of extensive use of meanings of some food items in English and Jukun.

#### Meaning Extension of Food Terms in JUKUN

Jukun: *U mā jī sò, U rī wā jàpè*

Meaning: If you do something, you must be ready to face the consequences

Jukun: *Āfyè wā jiji ābū bānchí, āfīn wātùtù ābū bāchò*

Meaning: People end up starting problems that affect others in the end

Jukun: *Bē nā shè bé shò nā gbè hē bá*

Meaning: If you do things in a hurry, destruction may likely follow

Jukun: *Ānwù byīn nā mbyā nū yò'a āhūnū kū rī dzwān byīn*

Meaning: To succeed in life you need a guide

#### Meaning Extension of Food Terms in English

That is your cup of tea

To use carrot and stick

An apple a day keeps the doctor away

To spill the beans

Man shall not live by bread alone

He sold his birth right for a yam pottage

God has buttered my bread

When meat is in, anger goes away

Dogs wag their tails not so much to you as to your bread.

#### Conclusion

The paper has contrasted the lexical field of foods in English and Jukun. The paper has also brought out the similarities and differences that exist in the two languages. Possible areas of difficulties that the learner is likely to encounter have been highlighted. The teacher of English to a Jukun learner should therefore understand these difficult areas, place emphasis on them,

and design teaching and learning strategies that will enhance better understanding. The paper therefore recommends that further research should be carried out on this and other areas in the Jukun language so as to develop the language to its full potential.

## References

- Bamgbose, M. G. (1996). *Nigerian standard English*, Ile Ife: Ohejomo Press.
- Bammer, F. S. (1992). *Morphological theory*, Chicago: Edward Arnold.
- Banjo, A. I. (1970). *A contrastive study of the syntactic and lexical rules of English and Yoruba*, Unpublished Ph.D Dissertation, University of Ibadan, Nigeria.
- Butari, N. U. (2010). *Lexico –semantic contrast of selected Jukun and English semantic fields*, An Unpublished Ph.D Dissertation”. Ahmadu Bello University, Zaria.
- Charlie, A. (2013). *An introduction to applied linguistics*, New Delhi: Random Exports. 207.
- Crystal, D. (1995). *Clinical linguistics*, London: Edward Arnold.
- Crystal, D. (2008). *A dictionary of linguistics and phonetics*, 395
- Essien, O. (2003). *National development of language and language Policy in Nigeria*”. Essien, O. & Okon, M. (Eds), Topical Issues in Sociolinguistics: The Nigerian perspective. Aba national Institute for Nigerian Language.
- Filani, I. (2013). *A contrastive analysis of three semantic fields of English and Ugboko*”. Adebite, W., Ogunsuji, A. & Taiwo, O. (Eds), Linguistics and the Glocalisation of African Languages for Sustainable Development. Ibadan: Universal Akada Books Nigeria Limited.
- Fromkin, V., Rodman, R. & Hyams, N. (2011). *An introduction to language*, Canada: Wadsworth Cengage Learning, 298.
- Frothingham, M. B. (2023). *Sapir-whorf hypothesis” (Linguistic Relativity Hypothesis). Theories, cognitive psychology: simplypsychology.org*, Retrieved 19<sup>th</sup> July, 2023. 10:12 am.
- Leafyplace, R. (2019). *Types of food –do you know all the various food categories”?* <https://leafyplace.com>food>. Retrieved 21<sup>st</sup> June, 2021. 4:07pm.
- Lobner, S. (2002). *Understanding semantics*, London: Hodder Education. 179.
- Nicolas, E. & Levinson, S. (2009). *The myth of language Universals and the Myth of universal grammar*, <https://psychonet.Apa.org>. Retrieved 4<sup>th</sup> July 2023. 7:45 am.
- Richards, J. C. & Schmidt, R. (2012). *Dictionary of language teaching and applied linguistics*, London: Longman.



## THE MOBILITY OF ADJUNCTS IN JUKUN CLAUSE

<sup>1</sup>Alli, Apaji Jones & <sup>2</sup>Ishaya, Yusuf Tsojon

<sup>1&2</sup>Department of English and Literary Studies

Federal University Wukari, Taraba State

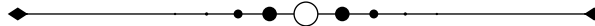

### *Abstract*

*The adjunct, been an optional element of the clause structure, possesses a striking feature; its ability to move from the last positions to the medial and initial positions within the clause structure. It is the feature of the adjunct in the clause structure that formed the background for this research, to describe, this time, adjunct in the Jukun language, which has not been given any prime of place in studies in Jukun. The few studies that exist in the language, for instance, scholars such as, Shimuzu, Fakuade, Butari and Ajiduku worked on the different aspects of the language ranging from contrastive, sociolinguistics, semantico-pragmatics and grammatic aspects of the Jukun spoken in Wukari and Takum. The Jukun-Ekpan dialect, the one spoken by the researcher, has not received any serious attention. This study focuses on the description of the Jukun-Ekpan adjuncts; how it can move from one part of the clause to another part without affecting the semantic of the clause. Systemic Functional Linguistics is the theoretical framework used in analyzing the data for the study. The findings show that just like in English, the Jukun adjunct can move to all the positions of the clause. The slight difference between the two languages is that in English, adjunct must move to all the three positions, but the Jukun data showed that only some adjunct can move to the three positions, some adjuncts only moved to two positions; the last and the initial positions. Any attempt to move them further distorted the semantic of the clause.*

**Keywords:** *Adjunct, clause structure and Jukun language*

---

### **Background of the Study**

Each language has its distinct world view and experience. The experience and the worldview of a particular language bring about its peculiarities. It is therefore necessary study structures in our indigenous languages to bring to the fore the intricacies of such a language. When a language is properly described, it affords ample opportunities to understand its structures

which prompt further research by those who are interested in studying it. Adjuncts though, an optional member of the clause structure is an importance member of the clause structure. It is a class of adverbials which are integrated into the clause structure. Of course, adverbial group is the group that performs the function of an adverb. One interesting thing about the adverbial group is its ability to move to any position within the clause. As it moves from one place to another within the clause, its functions change from circumstantial adjunct to conjunctive adjunct (connector) to modality. This study therefore is to see this peculiarity in the Jukun language. These functions could be similar to the function it performs in other language. But the fact here is that the observation made in this study is based on how it behaves in the Jukun language.

The Jukun language is a member of the Nigritic or Niger-Congo linguistic family (Ajiduku, 2013: v). The people are found in the Benue valley of the middle belt region of Nigeria, Smith (1972). Ajiduku (2013) opines that the language boasts of several dialects such as Wapana, Ekpan, Ichen, Wanu, Kona, Dampar, Wurbo, Wase, Gwana, Pindi ga and many others. The present research will be carried out in the Jukun-Ekpan dialect. The Jukun Ekpan is one of the numerous dialects of the Jukun language. It is mostly spoken in Wukari, Donga, Takum Local Governments of Taraba State and in some parts of Benue State. In Benue, they are popularly referred to as Ekpan Nyonyo. Jukun Ekpan, as speculated, is the second largest group, among the several Jukun dialects after Wapan. It is clear that, there are differences in some lexical and phonological aspects of their spoken language among the different groups.

### **Adjuncts**

The subject of adjuncts is a bit complex. The reason is because many things occur in the adjunct position. They can move from one place to another within the clause, can be realized by adverbial headed groups and prepositional headed group, can accept rank shifted clauses as elements of group structure and can occur more than once. The adjunct, therefore, according to Ojo (2011), is a class of adverbials which are integrated into the clause structure. In Bloor and Bloor (2004), adjuncts are said to be 'something joined to'. They further postulate that adjuncts are optional elements in the clause structure. They add that adjuncts are subdivided into three, such as; circumstantial adjuncts, conjunctive adjuncts and modal adjuncts. Circumstantial adjuncts deal or provide information about time or place. Conjunctive adjunct does the work of connection. The position of conjunctive adjunct is the initial position. The modal adjuncts are the kinds that show the writers attitude to the proposition. Halliday and Matthiessen (2004) define adjunct as an element that has not got the potential of being subject; that is, it cannot be elevated to the interpersonal status of modal responsibility. They add that adjunct is typically realized by an adverb group or prepositional group.

### **The notion of mobility of adjuncts**

The adjunct appears to have a peculiar behaviour different from other elements. In a normal clause, the adjunct occupies the fourth slot in the structure of the clause but because of its mobile nature it can move from the fourth slot to any other parts of the clause. It can move from the fourth slot to occupy the initial position or the medial position in the clause structure. For instance, let us look at the behaviour of the word 'carefully' in the clause below:

//he drove the car carefully// (last position)

//carefully, he drove the car// (initial position)

//he, carefully, drove the car// (medial position)

Because of its ability to move, the adjunct can split the verbal into two. For instance;

//He was speaking slowly//

// he was slowly speaking//

### Mobility of adjuncts in Jukun

As earlier stated in English, the adjunct has the ability to move to different parts of the clause depending on what function it wants to perform in that part: which are; circumstantial, conjunctive and modal. This appears to be similar in the Jukun language. In a normal Jukun clause, the adjunct occupies the fourth slot in the structure of the clause but its ability to move to other parts of the clause, it can move to the initial and medial position of the clause. For instance;

S            P            C            A  
//Mбайдum жи амijim **mumweine**//(last)

man the eat food the quickly  
'the man ate the food quickly'

A                    S            P            C  
//**mumweine**, mбайдum жи амijim// (initial position)

Quickly, man the eat food the  
'Quickly the man ate the food'

S                    A            P            C  
//Mбайдum, **mumweine** жи амijim// (medial)

Man the, quickly eat food the quickly.  
'The man quickly ate the food.'

### Methodology and Theoretical Framework

The data for this research was collected from a popular Jukun story, the lion and the goat. The clauses in the Jukun language were analysed to see if the structures comply with the standard structures of the SPCA, thereafter the adjuncts were moved to the three (3) different positions of last, initial and medial positions. The data were analysed using Systemic Functional Linguistics theoretical framework, propounded by M.A.K. Halliday. The structures of clauses of one of the stories were identified and analysed using the scale of delicacy, This means the analysis covers the primary, secondary and tertiary degrees of delicacy. The elements were first identified in Jukun and glossed in English for clarity of analysis.

### Data Analysis and Findings

In order to determine the ability of the adjunct to move from one position to another within a clause structure, some clauses that contain adjuncts in a popular Jukun story were selected for analysis. They adjuncts were moved to the three positions within the clause (initial, medial and last) to see if they can still make a meaning. They are glossed in English for clarity.

S                    P            A  
//Nukpim / hwebe/ **iskimbe Konkon de Ibwen**//

Story my is head on lion and goat.  
'My story is about the lion and the goat.'

A                                    S            P  
// **iskimbe Konkon de Ibwen** / Nukpim / hwe'//

head of lion and goat story my is

'about the lion and the goat is my story'

From above, we have the structure of the Jukun clause as SPA. The adjunct is /*iskimbe Konkon de Ibwen*/, meaning "about the lion and the goat" has the ability to move from its position as the last element in that clause to the initial position. Note that in this case, the adjunct cannot move to three places. The semantic of the whole structure might be distorted if it is forced to occupy the medial position.

A            S            P    C  
 // **Ukyin anye** / *Konkon / kyun dan ikyun* // (initial)  
 day certain, lion walked wrong walk.

'a certain day, the lion walked carelessly.'  
                  S            P    C            A  
 // *Konkon / kyun dan ikyun* / **Ukyin anye** // (last)  
 lion walked wrong walk day certain.

'the lion walked carelessly a certain day'  
                  S            A            P            C  
 // *Konkon / Ukyin anye* / *kyun dan / ikyun* // (medial)  
 Lion day certain walked wrong walk  
 'the lion, a certain day. walked carelessly'

This Jukun clause has ASPC as elements of clause structure. The first element /*Ukyin anye* / is an adjunct "a certain day" which is able to move to the three places within the clause.

S    P            A  
 // *A / ka kpu / inken uwa* //  
 he went fell inside pit  
 'he fell into a pit'

S    P            A  
 // **inken uwa** // *A / ka kpu* //  
 he went fell inside pit  
 'he fell into a pit'

The Jukun clause structural formular is SPA. The adjunct is /*inken uwa* / (into a pit) and is able to move to the initial position of the clause. In this case the adjunct cannot move to the medial position of the clause because it may distort the meaning of the clause.

S    P            A            C  
 // *A / dohwe / inken uwane / ukyin ufki* //  
 he slept inside pit days several.  
 'he remained in the pit several days'

A            S            P            C  
 // **inken uwane** / *A / dohwe / ukyin ufki* //  
 he slept inside pit days several.  
 'he remained in the pit several days'

S    P            C            A  
 // *A / dohwe / ukyin ufki / inken uwane* //  
 he slept inside pit days several.  
 'he remained in the pit several days'



The Jukun clause here has SPAC clause structure. The adjunct which occurred medially, is /i nke nu wa ne / (inside the pit) and is able to move to the three positions within the clause.

A S P  
// **Ukyin anye**/ *Ibwen*/ *baha vonzu* /,  
day certain, goat was passing by  
'a certain day, a goat was passing by'

S A P  
/ *Ibwen*/ **Ukyin anye**/ *baha vonzu* /,  
Goat, day certain, was passing by  
'a goat, certain day, was passing by'

S P A  
// *Ibwen*/ *baha vonzu*/ **Ukyin anye** //  
goat was passing by, day certain,  
'a goat was passing by, day certain'

The Jukun structural elements of the clause are ASP. / *Ukyin anye*/ (certain day) as the adjunct and could move to all the three positions of the clause.

S P C A  
// *a/ka ashzyi*/ **inken uwane** //  
he look eye inside pit the  
'he looked into the pit'

A S P C  
// **inken uwane** / *a/ka ashzyi* //  
he look eye inside pit the  
'he looked into the pit'

The Jukun clause has the clause structural elements of SPCA. The adjunct, the mobile element in the clause is /inken uwane/ (inside the pit). As demonstrated above, it can move from the last position to the initial position.

S P C A  
// *a/ de/ Konkon/ inken* //  
'he saw a lion inside'

A S P C  
// **inken** / *a/ de/ Konkon* //  
'inside, he saw a lion'

Here the Jukun language has the SPCA structural elements of the clause. The last element is an adjunct /inken/ which can occur at the last and initial positions of the clause.

S P A  
// *A / buzubo/ akayi* //  
'he came out'

A S P  
// **akayi** / *A / buzubo* //  
out he came  
'outside, he came'

The Jukun clause here has SPA as elements of clause structures with /akayi/ (outside) as the adjunct. It can occur as the last and initial elements in the clause.

A                      SP              C

// *Afdi abuzune* / a / *tubun* / *ukyen mbe Ibwen* //

when he came out, hand his held tail of goat the  
'when he came out, his hand held the tail of the goat'

S              P              C                                      A

// a / *tubun* / *ukyen mbe Ibwen* // *Afdi abuzune* //

when he came out, hand his held tail of goat the  
'when he came out, his hand held the tail of the goat'

S                              P              A                                      C

// a / *tubun* / *Afdi abuzune* / *ukyen mbe Ibwen* //

when he came out, hand his held tail of goat the  
'when he came out, his hand held the tail of the goat'

The Jukun clause here has ASPC as element of clause structures with a subordinate clause /*Afdi abuzune* / (when he came out) as the adjunct. It was able to move to the initial, medial and last positions of the clause.

It is very obvious that the adjunct is a mobile element in the clause structure. This can be seen from its ability to occupy the last, medial and initial positions within the clause structure. Actually a normal clause has should have the subject, predicator, complement and the adjunct, complying with the standard structure of a normal clause. The only compulsory element is the predicator. All other elements are optional. The adjunct happens to be one of the optional elements. But it is worthy of note that the adjunct is a very active and pragmatic member of the clause structure. This is because of its ability to be headed by different word groups and also to move to different positions within the clause.

**Conclusion**

It is very clear that Jukun been one of the world languages have distinct behaviour and structures. One of the features of its universality is the fact that it possesses the adjunct as one of the elements of the clause structure. One of the striking attributes of the adjunct is the fact that it is mobile. It possesses the ability to move from the last position to the medial and initial positions within the clause. The finding from the analysis of the data show that just like in English, the Jukun adjunct can move to all the positions of the clause. The difference in this study therefore is that in English, adjunct must move to the three positions, but our analysis in this study showed that some Jukun adjunct could move to three positions and some to only two positions; the last and the initial positions. Any attempt to move them further distorted the semantic of the clause.

## References

- Adebija, E. (2004). *Multilingualism: A Nigerian case study*, Trenton: Africa World Press.
- Ajiduku, B. A. (2013). *The elements of Jukun Grammar: An introduction*, Jalingo: The Advertiser Education Associates Ltd.
- Akoga, N. B. (2012). *Apa-Jukun history of the Benue valley: A portrait of the socio-political history of Ibi from the 19<sup>th</sup> to 21<sup>st</sup> century*, Makurdi: Oracle Business.
- Alli, A. J. (2016). *A contrastive study of nominal group structures of Jukun and English*, M.A Thesis University of Ibadan, Ibadan
- Bloor, T. & Bloor, M. (2004). *The functional analysis of English*, London: Holder Education.
- Choy, P. & Clark, D. G. (2006). *Basic grammar and usage*, Boston: Wadsworth: Cengage
- Cook, V. & Newman, M. (1996). *Chomsky's universal grammar: An introduction*, Oxford: Blackwell Publishers.
- Dittmar, N. (1976). *Sociolinguistics*. Frankfurt: Edward Arnold.
- Eggins, S. (1994). *Introduction to systemic functional linguistics*, Wellington: Continuum.
- Ekpe, M. B. (2010). *A course guide: National Open University of Nigeria*, Abuja: NOUN.
- Halliday, M. A. K. (1989). *Introduction to functional grammar*, Oxford: Edward Arnold
- Halliday, M. A. K. (1989). *Spoken and written discourse*, Oxford: Oxford University Press.
- Halliday, M. A. K. (1994). *An introduction to functional grammar*, Oxford: Edward Arnold
- Halliday, M. A. K. & Hassan, R. (1997). *Cohesion in English*, London. Longman
- Halliday, M. A. K. & Matthieseen, M. I. M. (2004). *An introduction to functional grammar*, London: Holders Education. Hongkong: Longman Group Ltd.
- Jacobs, R. A. (1995). *English syntax: A grammar for English language professionals*, New York:
- Morley, G. D. (1995) *An introduction to systemic grammar*, London: Macmillan Publishers Limited.
- Ojo, J. O. (2011). *A contemporary functional grammar of English*. Ago-Iwoye: Olabisi Onabanjo University Press.
- Osisanwo, W. (1999). *An introductory analysis grammar of English*, Lagos: Femolus-Fetop.

- Ouhalla, J. (1999). *Introducing transformational grammar: From principles and parameters to minimalism*, New York: Arnold.
- Quirk, G. & Greenbaum, S. (2000). *A university grammar of English*, Edinburgh: Pearson
- Smith, E. H. (1972). *Nigerian harvest*, Kaduna: Baraka Press and Publishers.
- Thompson, G. (1996). *Introducing functional grammar*, Oxford: Oxford University Press Inc.
- Umoh, O. A. (2015). *The head parameter in English and Ibibio*. M.A Thesis, University of Ibadan, Ibadan.
- Yusuf, M. A. (2011). *Hausa grammar: An introduction*, Zaria: ABUP Ltd.



## IMPACT OF CAPITAL FLIGHT ON DOMESTIC INVESTMENT IN NIGERIA

<sup>1</sup>Ishaku Rimamtaanung Nyiputen <sup>2</sup>Okoh Abo Sunday <sup>3</sup>Yakubu Maigaji Ibrahim

<sup>4</sup>Uwaeke, George Uchechukwu & <sup>5</sup>Enyikah Illiya

<sup>1,2,3&5</sup>Department of Economics, Federal University Wukari, Taraba State Nigeria,

<sup>4</sup>Department of Economics, Ebonyi State University Abakaliki

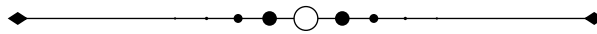

### **Abstract**

Concern has been raised about Nigeria's domestic investment's consistent fall, especially in light of the country's increasing capital flight. As a result, this study looked at how capital flight affects domestic investment in Nigeria. Despite the fact that this topic has been the subject of many studies, to the best of the researcher's knowledge, none of these studies adequately calculated capital flight since they overlooked flight caused by trade miss invoicing. Thus, this study closes this gap. Additionally, the study expressly took into account domestic saving and private sector credit, which are factors that influence domestic investment but have received less attention in earlier studies done in Nigeria. The ARDL technique was utilized in this study to empirically investigate the impact of real capital flight, domestic saving, and domestic credit to the private sector on domestic investment in Nigeria. Time series data encompassing the years 1999 through 2021 were used in this analysis. The World Development Indicators (2021), CBN Statistical Bulletin (2021), and IMF Direction of Trade Statistics provided the information for the analysis (2021). The results showed that in Nigeria, real capital flight, currency rates, and interest rates both short- and long-term encourage local investment. In contrast, domestic saving, domestic lending to the private sector, and real GDP all have a sizable positive impact on domestic investment over the course of both the short and long term. A significant policy implication is that the government should reduce the prevalence of insecurity in order to foster an environment that encourages investment.

### **Background to the Study**

Achieving macroeconomic balance and economic growth requires a sufficiently robust domestic investment performance, which is a crucial prerequisite. Despite the importance mentioned above, the domestic investment figures in Nigeria's economy have been patchy and inconsistent. For instance, Nigeria's domestic investment as a proportion of GDP was 38.3% in 1999. Over the following 13 years, it steadily decreased to 14.7% in 2017. (CBN, 2018). Although it increased to 19% the next year, the percentage fell to 18.25% and 8.25%, respectively, in 2019 and 2020. (WDI, 2020).

The Nigerian government has made various attempts to improve the business climate due to the repercussions it has on the economy. To enhance the availability and accessibility of loans for investment purposes, the Central Bank of Nigeria, for example, ordered all deposit money banks to maintain a minimum loan to deposit ratio (LDR) of 60% commencing in September 2019. Despite these initiatives, domestic investment in Nigeria has remained notably low when compared to the staggering numbers of capital flight.

Due to the aforementioned difficulty, various lines of research have been devoted to figuring out how capital flight affects local investment in Nigeria. However, a detailed examination of these publications reveals that they lacked adequate capital flight measurement. For instance, Adetiloye (2012) claimed to look into how capital flight affects domestic investment in Nigeria, but a close examination of this study shows that the variable for capital flight was glaringly absent from the estimated equation. Adesoye, Maku, and Atanda (2012) found a positive but negligible correlation between domestic investment and capital flight in a related study. This unexpected outcome, which defied theory, may have been caused by the study's use of the World Bank's residual measure of capital flight, which Ndikumana, who was referenced in Ndiaye, had found to be flawed (2009). Ndikumana noted correctly that because the residual measure does not account for capital transfers resulting from trade miss-invoicing and instead uses trade statistics from the official balance of payments tables at face value, it either overstates or understates the true value of capital flight. Due to trade misinvoicing, official balance of payments figures on imports and exports are frequently of poor quality in practice. However, Effiom et al. (2020) obtained a result in line with theory while using the identical residual measure. A component that certainly looks more significant, at least in an economy like Nigeria where the private sector controls a substantial percentage of productive activity, was overlooked in the study along with the use of the made-fault metric of capital flight.

Additionally, because domestic investment is the study's dependent variable, it is necessary to explicitly include its key determinants in the model. This is done to make sure that the calculated equation can adequately explain domestic investment behavior. Neo-classical economists claim that domestic investment is stimulated by rising domestic saving based on this. Similar to how Fofack and Ndikumana (2010) and Okorie and Chikwundu (2019) have demonstrated, domestic investment is directly impacted by the volume of and availability to credit available to private sector borrowers. However, prior research on the subject under consideration has failed to explicitly include these variables in their model, instead including them in the error term, which has frequently led to noticeably low explanatory power of the estimated model. This is despite the fact that these variables play a crucial role in influencing the level of domestic investment. Adetiloye (2012), who made an attempt to account for



domestic saving, used foreign exchange reserves as a proxy; this metric has received harsh criticism in the literature for failing to account for the private saving component.

The present study, in contrast to Ndikumana cited in Ndiaye (2009), will revise capital flight estimates for two significant effects (the inflation effect and the trade miss invoicing effect) that have been overlooked in earlier studies conducted in Nigeria, possibly as a result of the meticulous procedures needed to determine their values. Real capital flight estimates are those that have been obtained after these effects have been taken into account. Additionally, the study will look into the impact of domestic saving and domestic lending to the private sector, which, despite being important factors in determining investment, have received less attention in studies done in Nigeria thus far.

It is still important to experimentally determine whether these significantly reduced investment levels in Nigeria are the result of increasing capital flight waves notwithstanding the existence of official statistics in the economy. In light of this, it is necessary to determine how capital flight has affected Nigerian domestic investment.

## **Literature Review and Theoretical Framework**

### **Review of Basic Theories**

#### **Investment Diversion Hypothesis**

Kindleberger first proposed the investment diversion theory in 1966. According to his definition, the investment diversion effect results in increased direct investment in some nations and decreased direct investment in other nations as a result of the relocation of production facilities. He contends that the amount of capital leaving a country is inversely correlated with the amount invested there.

The theory is predicated on the suppositions of perfect cross-border capital mobility, the existence of an unfavorable investment environment at home and better investment opportunities abroad, full utilization of all available resources, and rational investors.

Based on the aforementioned premises, the hypothesis postulates that because domestic economic agents move scarce capital resources away from the domestic economy to foreign countries with better investment climate due to the simultaneous existence of domestic imperfections and superior investment opportunities abroad. When productive resources are diverted to other countries, domestic investment suffers, leading to low output growth and high unemployment. These domestic flaws include low domestic saving as a result of high tax rates, the absence of investor-friendly credit schemes, insecurity, and exchange rate volatility. Better investment opportunities, on the other hand, can be found abroad thanks to factors like a wider selection of financial instruments to experiment with, lower tax rates, and political and economic stability.

The investment diversion hypothesis is relevant to developing economies where macroeconomic and political uncertainties are observably high. These uncertainties include price instability, exchange rate fluctuations, political unrest, and others.

The theory, though, is heavily contested. It is predicated on the idea that capital outflows would have increased domestic investment. However, how true this is will vary depending on

how the money would have been used (financing consumption loans, or capital investment). Despite a stable macroeconomic and political environment, domestic investment is unlikely to increase in nations where domestic resources are primarily used to finance consumption loans. The second supposition is that capital is completely mobile across borders. However, this is not always the case because different nations may impose regulations that raise the cost of transporting resources from one nation to another or limit the amount of capital that can enter and leave their economy. Consequently, capital becomes less mobile.

Despite its flaws, it has been acknowledged that the investment diversion hypothesis helped to explain one of the well-known unfavorable effects of capital flight in the participating countries. Additionally, it has brought attention to the connection between financial loans, saving, and investment. It predicts that internal flaws such as the lack of financial loans for investors and decreased saving brought on by increased taxes will lead to low levels of investment in an economy.

### **Debt Driven (Debt Overhang) Hypothesis**

Stewart Myers first proposed the debt-driven concept in 1977, and Paul Krugman later refined it in 1988. However, the hypothesis explains how, through capital flows, investment decisions react to changes in the debt stock. It implies that citizens are moving their money abroad due to rising debt levels, which skews the chances of making the best possible investments in the future. According to the hypothesis, a nation's high level of external debt makes it more likely that the country will experience a devaluation of its currency, a fiscal crisis, and a tendency to crowd out domestic capital and seize assets in order to pay off its debt, which will make it necessary to divert resources to other nations. Due to the lack of resources to finance internal investment, there is a drop in domestic investment.

According to the theory, domestic investment, capital flight, and external debt are all interdependent and reinforce one another. The fuel for capital flight, which lowers the motivation to invest and results in sluggish growth that necessitates borrowing, is external debt. The cycle is maintained by additional borrowing and debt, which in turn fuels increased capital flight and decreased domestic investment.

The theory does, however, have some drawbacks. According to Karagol's (2005) argument, since each country differs, the debt-driven theory cannot be universally applied. A nation won't have the same pressure on investment if it does not view debt as something that must eventually be repaid or has the option to roll over debt. Some countries may never have to repay their debt in full since the market has given them the confidence to roll over debt from year to year and only pay interest. Developed nations may receive margin calls on their debt much later than emerging nations, who may be viewed as being more risky and hence lacking in credibility during periods of uncertain financial markets. If borrowed money is used wisely, external debt may not necessarily limit the level of domestic investment, rather it will increase the level of economic activity in the local economy, according to Williams (2016).

### **Trend Analysis of Variables**

The essence of this analysis is to give an overview of the movement of the variables over the study period (1999-2000).

**Figure 2.1: Trend of Domestic Investment, Real Capital Flight, Domestic Saving and Domestic Credit to Private Sector in Nigeria (1999-2020).**

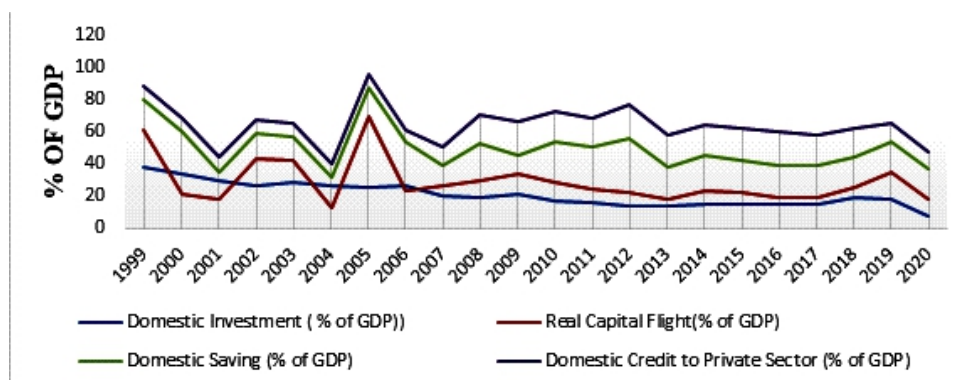

**Source:** Researcher's computation (2021); using data derived from WDI (2021).

By following the aforementioned trend, it was possible to conclude that, between 1999 and 2020, the Nigerian economy was characterized by erratic levels of domestic investment, with the low-level periods outpacing the high-level ones. In fact, domestic investment (as a percentage of GDP) did not go above the level of 38 that was recorded in 1999 during the study period.

However, a closer look at the figure above shows that for Nigeria, domestic credit to the private sector and domestic saving both had curves with the same shape throughout the research period, with domestic credit's curve being higher than domestic saving's. This observation may be explained by the fact that domestic credits to the private sector are a result of financial intermediation and include some savings from the excess spending units. In other words, loans are provided from the economy's stock of savings. Furthermore, the domestic credit curve's position above the domestic saving curve demonstrates that Nigerian borrowers' access to financial credits is not solely dependent on domestic saving; it may also be supported by the entry of foreign funds or the production of new currency.

However, domestic investment estimates in Nigeria between 2012 and 2017 averaged 18%, a 3 percent rise from the 15 percent recorded in 2011. This increase in domestic investment figures can be attributed to the successful policies and programs that were put in place during that time. For instance, between 2012 and 2015, President Goodluck Jonathan of Nigeria, who was in office at the time, implemented the Subsidy Re-investment and Empowerment Programme (SURE-P), which boosted domestic investment by reinvesting the money made from the removal of subsidies into important economic sectors. Additionally, the current administration's Economic Recovery and Growth Plan (ERGP), which was introduced in 2016 and aimed to diversify the economy through investments in the human and other sectors of the economy, among other accomplishments, increased domestic investment.

Nigeria saw a decrease in each of the examined indicators in 2020. Particularly, domestic investment was around 8%, real capital flight was at 10%, domestic saving was at 18% and domestic credit to the private sector was at 11%, respectively. However, given that the year was designated for absolute lockdown, this should not be surprising. In general, the third quarter

of 2020 saw a decline in the Nigerian economy. This was primarily attributed to the slowdown in economic activity brought on by low oil prices and the impact of the Covid-19 pandemic. The pandemic not only caused the economy to stagnate, but there were also significant levels of unrest at the end of the year caused by the end SARS protest, which resulted in the loss of lives and property. limiting economic activity inside the economy as a result.

### **Empirical Literature Review**

Several studies, some of which have their domicile in Nigeria and others in other African nations, have articulated empirically the impact of capital flight on domestic investment in a country. We'll look at these studies right away. Between 1970 and 2008, Ndiaye (2009) looked at how capital flight affected domestic investment in the Franc zone. The study used a three-stage methodological approach based on the objectives. It started by looking at how capital flight affected overall domestic investment. To ascertain whether the effect of capital outflow on total domestic investment is through private investment or public investment, it then looked at the impact of capital flight on private investment and public investment. Domestic investment, real capital flight, real GDP growth rate, private sector credit, and inflation rate are the variables used in the study. The Ordinary Least Squares (OLS) method was used in the study. According to the econometric analysis, capital flight has a variety of negative effects on domestic investment. Private investment stood out more than public investment as being negatively impacted by capital flight. In light of these findings, the study suggests that capital flight repatriation can aid in increasing domestic investment. It also suggested lowering macroeconomic and institutional uncertainty to reduce the possibility of real domestic asset values of private investors declining, thereby promoting capital repatriation.

Umoro (2010), examined the impact of capital flight on domestic investment in Nigeria between 1980 and 2005 using data on capital flight, domestic private investment, domestic public investment, interest rate, GDP growth rate, and exchange rate. The Ordinary Least Squares (OLS) method was used in the analysis for the study. The OLS results, however, revealed that all independent variables, with the exception of exchange rate, which had a negligible impact on domestic investment, were correctly signed and statistically significant. The study attributed such exchange rate findings to the existence of multiple exchange rates in the economy.

Using the Generalized Method of Moments (GMM), Fofack and Ndikumana (2010) showed that real adjusted capital flight significantly reduces total domestic investment and private investment in Sub-Saharan African countries, while its impact on public investment was found to be insignificant, thus suggesting that the negative effect of capital flight on domestic investment operates more through private investment than via public investment.

Using the residual approach of capital flight estimation, Adesoye, et al. (2012) examined the correlation between capital flight and domestic investment in Nigeria adopting the Auto Regressive Distributed Lag (ARDL) technique and data covering the period 1970-2006. Variables employed in the study include: capital flight, domestic investment, political instability, and quality of institution. The study established inconsistent results with theory. Specifically, the study found capital flight to be a positive but insignificant variable influencing domestic investment in Nigeria. Political instability had a significant negative impact while quality of institution impacted positively on domestic investment.



Adetiloye (2012), explored the role of capital flight in determining domestic investment in the Nigerian economy over the period 1986-2010. The study employed the Ordinary Least Squares (OLS) in the time series. The variables used are domestic investment, capital flight as estimated by World Bank, public sector borrowing requirement, domestic savings and average exchange rate. Augmented Dickey Fuller (ADF) and Hadri panel unit roots tests were used to test for stationarity and the following information surfaced: None of the variables was stationary at level meaning they all have unit roots. But all the variables became stationary after first difference with the exclusion of exchange rate. However, all the variables became stationary after second difference. Public sector borrowing and domestic investment in comparison clearly show a negative sign with a t statistic of -3.021, which is insignificant at 0.05 level. Average exchange rate and domestic savings were revealed to be positively significant with t statistic of 4.531 and 2.790 respectively. The study therefore recommends further floating of the exchange rate and transparency in its management. It also recommends that policies to encourage autonomous investment both private and public sectors, be put in place.

Salandy and Henry (2013) empirically examined the impact of capital flight on investment and growth in Trinidad and Tobago. In line with the objectives of this study, secondary data were obtained, covering the period of 1971 to 2008. In conducting the analysis, two econometrics estimation techniques were employed: the Vector Error Correction Mechanism (VECM) for the short run and long run analysis and the Generalized Method of Moments (GMM) (GMM). Domestic investment, RGDP growth rate, capital flight as estimated by the residual approach, exchange rate, and external reserve are the variables used in the analysis. Following the outcome of this study, it concluded that capital flight negativity influenced the two dependent variables: investment and growth. It was recommended that government should create an enabling environment for investment by encouraging more inflow of fund from abroad and dissuade outflow of funds by creating investment outlets. The monetary authority should ensure capacity building for local investment.

Using the Ordinary Least Squares (OLS) technique, Yalta (2014) examined the effect of capital flight on investment in Cameroon from 1975 to 2010. By bifurcating domestic investment into private and public components, as well as employing other variables such as exchange rate, domestic saving, interest rate, and real GDP, the study was carried out. The OLS result showed that capital flight dramatically reduces private investment, but does not have any significant effect on public investment.

Saheed and Ayodeji (2014), studied the impact of capital flight on investment spending in Nigeria between 1980 and 2013, using the Ordinary Least Squares (OLS) technique. The variables used are gross capital flight, inflation, exchange rate and domestic investment. The study found that capital flight and inflation had a detrimental effect on Nigerian domestic investment spending. The outcome showed that the economy's overly high inflation rate was what caused inflation to have a negative effect. However, domestic investment benefited from the exchange rate.

Yamesin (2014) looked at the impact of capital flight on investment and how that impact changed as a result of financial liberalization policies for 22 emerging market nations between 1975 and 2010. According to the empirical results, capital flight decreased private investment

but had no discernible impact on public investment in these nations. Gachoki and Nyang'oro (2016) used the Ordinary Least Squares (OLS) method in a study centered on Kenya to examine the effect of capital flight on domestic investment from 1989 to 2014. Variables like domestic investment, capital flight, external debt, real interest rate, and domestic savings are covered by the analytical framework. According to the study, capital flight has a negative effect on investment in Kenya. According to the study, domestic investment is positively correlated with factors like debt stock and domestic savings, while domestic investment is negatively correlated with real interest rates. The study suggests that policies be implemented to encourage both private and public savings based on the findings. In addition, measures to prevent the flight of domestic capital were advised.

In Cameroon, from 1970 to 2013, Wujung and Mbella (2016) looked at the relationship between domestic investment and capital flight. In the time series, the study used the Fully Modified Least Squares (FMOLS) method. Capital flight, domestic investment, real interest rate, and real GDP are among the variables used in the study. It was found that domestic investment and capital flight are negatively correlated. Real interest rates are another another factor that have a sizable detrimental effect on domestic investment. On the other hand, it was discovered that domestic investment had a positive correlation with real GDP.

Between 1990 and 2015, Akani (2016) looked at how capital flight affected domestic investment in Nigeria. Gross capital flight, domestic investment, political unpredictability, interest rate differentials, and real GDP are some of the variables used. The Fully Modified Least Squares (FMOLS) method was used to evaluate the data, and the results showed that capital flight had little impact on the volume of domestic investment in Nigeria. Political unrest and the difference in interest rates had a considerable negative impact on domestic investment, whereas real GDP had a big positive influence. Between 1986 and 2016, Aderoju (2017) looked at the effects of capital flight on domestic investment in Nigeria.

The study's variables were gross domestic investment, capital flight, currency rate, and inflation rate. The analysis used the Ordinary Least Squares (OLS) method. According to the study, Nigeria's gross domestic investment has a statistically significant positive link with capital flight, exchange rates, and inflation rates.

Using data from the years 1980 to 2017, Effiom et al. (2019) examined the impact of capital flight on domestic investment in Nigeria. The analytical approach includes factors including real GDP, total debt, capital flight, domestic investment, institutional quality as evaluated by contract-intensive money, and real GDP. To check for stationarity, the Philips Perron test and the enhanced Dicker-Fuller test were used. It is necessary to use the Auto Regressive Distributed Lag (ARDL) methodology to estimate the short and long run co-integration relationship in the model because the unit roots results show that the variables are integrated of different orders. The findings indicate that there is a long-term relationship between the variables. The only variable in the model that did not have a negative coefficient was institution, which had a correctly signed variable but was not statistically significant. The independent study variable significantly and negatively affected domestic investment. In particular, the long-term effects end up being worse than the short-term effects. The report suggested that in order to ensure that there are investable funds accessible inside the domestic economy for the purpose of investment, government efforts should be focused on reducing the



illicit outflow of money. Additionally, the federal government should step up efforts to recover stolen assets from foreign accounts and its anti-corruption campaign since this will enhance the nation's reputation and draw foreign capital for Nigerian investment reasons.

Effiom et al. (2020) used variables such federal government investment, state government investment, capital flight, currency rate, real GDP, and interest rate to study the asymmetric effects of capital flight on domestic investment in Nigeria between 1980 and 2018. The Non-linear Auto Regressive Distributed Lag Model was used in the analysis of the study. It was discovered that capital flight had a large adverse impact on investments made by the federal government but a negligible impact on investments made by state governments. Both investment components were negatively impacted by interest rates, whilst domestic investment components were positively impacted by real GDP and currency rates.

Orji, Ogbuabor, Kama, and Orji (2020) looked into how capital flight affected Nigeria's economic expansion. Data from the CBN statistical bulletin for the years 1981 to 2017 were used in the analysis. For the investigation, the Autoregressive Distributed Lag (ARDL) bounds test approach was used. According to the study, both short- and long-term economic growth are severely reduced by capital flight. Money supply, loans to the private sector, and domestic investment are other factors that have been discovered to have a substantial impact on economic growth. The study also demonstrated that domestic investment in Nigeria is negatively impacted by capital flight, exchange rates, and interest rates. In order to prevent capital flight and make the economy competitive and alluring for domestic investment, which promotes economic growth, the study advised proactive governmental actions. Every time the political climate is favorable for it, expansionary monetary policy should be implemented to increase the money supply. The aforementioned empirical reviews show that most studies have inadequately measured capital flight. Even so, the studies that accurately quantified capital flight—Ndiaye (2009) and Fofack and Ndikumana (2010)—focused on Sub-Saharan Africa and French-speaking Africa, respectively. No country-specific research has measured capital flight to take the consequences of inflation and trade misinvoicing into account. Additionally, it should be noted that few studies, if any, expressly analyzed domestic saving and credit to the private sector in Nigeria.

## **Methodology**

### **Theoretical Framework**

The basic theory used in this research is Kindleberger's "investment diversion hypothesis" (1966). According to the investment diversion hypothesis, economic agents divert scarce capital resources from domestic economies to those in other countries that provide better investment possibilities because of macroeconomic and political concerns. Due to the diversion of these limited resources, there are less investable funds, which limits total domestic investment.

The hypothesis was chosen for two main reasons: first, its underlying presumptions roughly reflect the situation in Nigeria in actuality. Nearly every region of the nation is today afflicted by the scourge of political unrest. For instance, there are armed bandits in the North West, Fulani herdsman mayhem in the North Central, the Boko Haram Islamist insurgency in the North East, separatist uprising in the South East, kidnappings and the sabotaging of Nigeria's oil facilities and resources in the South South, as well as unidentified gunmen in all

geopolitical zones. Additionally, the nation is experiencing macroeconomic concerns like fluctuating exchange rates, unstable pricing levels, unpredictable growth rates, and so forth. Second, the hypothesis was accepted because it takes into account the important study variables—real capital flight, domestic saving, and domestic lending to the private sector—and demonstrates how each influences domestic investment.

### Model Specification

As stated in the theoretical framework, this study utilizes the Kindleberger (1966) investment diversion hypothesis to ascertain the effect of capital flight on domestic investment in Nigeria. It uses a modified version of the empirical model employed by Effiom et al. (2020), which was cited in the empirical literature review, for equation estimation. As the explanatory factors employed in the model have been identified by Oyedokun and Ajose (2018) among others as the determinants of domestic investment in Nigeria, the model was chosen to ensure that the behavior of the dependent variable is fully accounted for. Real GDP, interest rates, and exchange rates are some of these explanatory variables.

But in the current analysis, domestic investment is the dependent variable, whereas real capital flight, domestic saving, domestic lending to the private sector, exchange rate, interest rate, and real GDP are the independent factors. However, Pesaran et al ARDL is model (Autoregressive Distributed lag model) framework was used in this study (2001). The behavior of the time series data, which exhibit different integration orders, led to the selection of this technique. Some are integrated with orders of one and zero, indicating the possibility of a long-term link between the dependent variable and the study's independent variables. ARDL is the based way to capture the explanatory variable's impact on the dependent variable in both the short and long terms. The model for the study in its functional version is described as follows using the theoretical framework:

$$DI = f(RKF, DS, DCPS, ER, IR, RGDP) \tag{3.1}$$

Where:

DI = Domestic investment, RKF= Real capital flight, DS = Domestic saving  
 DCPS = Domestic credit to private sector, ER = Exchange rate, IR = Interest rate  
 RGDP = Real gross domestic product

The mathematical form of the model is:

$$DI = \beta_0 + \beta_1 RKF + \beta_2 DS + \beta_3 DCPS + \beta_4 ER + \beta_5 IR + \beta_6 RGDP \tag{3.2}$$

The econometrics form of the model is:

$$DI_t = \beta_0 + \beta_1 RKF_t + \beta_2 DS_t + \beta_3 DCPS_t + \beta_4 ER_t + \beta_5 IR_t + \beta_6 RGDP_t + \mu_t \tag{3.3}$$

Where:

$\beta_0$  = Intercept,  $\beta_1 - \beta_6$  = parameters of the explanatory variables.

$\mu_t$  = Error Term

To illustrate the ARDL modelling approach, equation 3.3 will be rewrite as follows:

$$\Delta \ln(DI)_t = \beta_0 + \beta_1 \ln(RKF)_{t-1} + \beta_2 \ln(DS)_{t-1} + \beta_3 \ln(DCPS)_{t-1} + \beta_4 \ln(ER)_{t-1} + \beta_5 \ln(IR)_{t-1} + \beta_6 \ln(RGDP)_{t-1} + \sum_{i=1}^m \gamma_1 \Delta \ln RKF_{t-i} + \sum_{i=1}^m \theta_2 \Delta \ln DS_{t-i} + \sum_{i=1}^m \eta_3 \Delta \ln DCPS_{t-i} + \sum_{i=1}^m \mu_4 \Delta \ln ER_{t-i} + \sum_{i=1}^m \pi_5 \Delta \ln IR_{t-i} + \sum_{i=1}^m \varphi_6 \Delta \ln RGDP_{t-i} + \varphi_1 ECM1_{t-1} + \mu_t$$

Where:

$\beta_0$  = the intercept,

$\beta_1, \beta_2, \beta_3, \beta_4, \beta_5, \beta_6$  = the long-run variables coefficient

$\gamma, \theta, \eta, \mu, \pi, \psi$  = the short run coefficients of the variables.

$\Delta$  = difference operator,

$m$  = lag length of the variables

$\phi_1$  = the Speed of adjustment

$ECM_{t-i}$

$\mu_t$

$H_0: \beta_0 = \beta_1 = \beta_2 = \beta_3 = \beta_4 = \beta_5 = \beta_6 = 0$  (No long run relationship exist)

### Measurement of Variables

Domestic investment is the model's dependent variable and a measure of physical investment used to calculate GDP, which is a gauge of a country's economic activity. Replacement purchases, net capital asset additions, and investments in inventory are also included. Gross fixed capital creation as a percentage of GDP serves as a proxy for domestic investment.

**Real Capital Flight:** Real capital flight is determined by subtracting total capital inflows from recorded foreign exchange outflows after accounting for the effects of inflation. The literature research shows that there are various methodologies that may be used to estimate capital flight. The World Bank residual method, however, has been shown to be superior in the literature. Since capital flight results from cross-border capital flows, the approach is more comprehensive and provides a capital flight measurement that accounts for the majority of cross-border capital transactions, such as external debt and foreign direct investment. Even so, the method, like others, yields statistics for capital flight that are either inflated or deflated. This is because it depends on current account data and balance of payments statistics, which are misreported as a result of the deliberate fabrication of trade invoices. As a result, we adopt and modify the residual measure for two significant effects in accordance with the methodology created by Ndikumana (2001) and applied by Ndiaye in order to cover the indicated empirical knowledge gap (2009). First, we use data from the IMF's Direction of Trade Statistics Yearbook to compare trading partner data in the residual capital flight equation to incorporate trade mis-invoicing. As a result, we have nominal capital flight estimates that have been corrected for trade misinvoicing. Second, we calculate modified capital flight estimates that account for inflation.

We compare Nigeria's export and import data to those of its trading partners in order to determine the country's trade misinvoicing. Here, we used the reported trade numbers of the Industrialized trading partners as the standard of reference to determine invoicing biases. We assume that these countries' trade data are generally accurate because they typically have lower corruption perception indices, higher investment incentives, and better data reporting systems. The discrepancy between these and the data from Nigeria is therefore seen as proof of Nigeria's trade misinvoicing.

With industrialized nations, export misinvoicing is calculated as follows:

$$XMIS_i = ICM_i - (NX_i * CIF_i / FOB_i) \quad 3.5$$

Where;

$XMIS_i$  = Nigeria's exports mis invoicing

$ICM_t$  = value of industrialized countries imports from Nigeria as reported by the industrialized trading partners.

$NX_t$  = Nigeria's exports to its industrialized trading partners as reported by Nigeria.

$CIF_t/FOB_t$  = cost-insurance-freight to free-on-board ratio. In order to compare trade flows between two trading partners, we need to account for transport and insurance costs associated with imports. In other words, imports are adjusted downwards by a country-specific  $CIF_t/FOB_t$  ratio.

A positive sign on  $XMIS_t$  indicates net export under-invoicing, implying capital flight. On the other hand, a negative sign indicates net export over-invoicing.

Import mis invoicing with the industrialized countries is computed as:

$$MMIS_t = NM_t - (ICX_t * CIF_t/FOB_t) \quad 3.6$$

Where:

$MMIS_t$  = Nigeria's imports mis invoicing

$NM_t$  = value of Nigeria's imports from industrialized countries as reported by Nigeria.

$ICX_t$  = Industrialized countries exports to Nigeria as reported by the industrialized trading partners.

$CIF_t/FOB_t$  = cost-insurance-freight to free-on-board ratio

A positive sign on  $MMIS_t$  indicates net over-invoicing of imports, implying capital flight. On the other hand, a negative sign indicates net import under-invoicing.

Total trade mis invoicing with the industrialized countries is computed as:

$$TTMIS_t = XMIS_t + MMIS_t \quad 3.7$$

Where:

$TTMIS_t$  = total trade mis invoicing while,

All other abbreviations remain what they represent as shown above.

The total trade mis invoicing is then added to the residual estimates of capital flight to obtain what Ndikumana (2001) referred to as adjusted capital flight. This is shown below:

$$ADJKF_t = (\Delta DEBT_t + NFDI_t) - (CAD_t + \Delta ER_t + TTMIS_t) \quad 3.8$$

Where;

$ADJKF_t$  = adjusted capital flight while,

All other abbreviations remain what they represent as shown above.

At this point, we make inflation adjustments, so as to obtain real capital flight. In view of the facts that our data are expressed in dollars, and capital flight relates to producer goods, we use the United States producer price index to deflate the adjusted flight estimates, as shown below:

$$RKF_t = ADJKF_t / PPI_t \quad 3.9$$

Where;

$RKF_t$  = real capital flight

$PPI_t$  = United States producer price index (constant = 2010).

Taking into account the two adjustments indicated above, we can write the real capital flight equation as follows:

$$RKF_t = \frac{(\Delta DEBT_t + NFDI_t) - (CAD_t + \Delta ER_t) + TTMIS_t}{PPI_t} \quad 3.10$$

$PPI_t$

**Domestic saving:** The remainder of what is eaten from gross domestic product is known as domestic saving or gross domestic saving. Here, it is calculated as the gross domestic saving as a proportion of GDP.

**Domestic credit to the private sector:** Financial resources offered by financial institutions to the private sector are referred to as Monetary authorities and deposit money banks are examples of financial companies. Here, domestic credit to the private sector is expressed as a share of GDP.

**Real effective exchange rate:** serves as a proxy for the exchange rate. The weighted average of a country's currency versus a basket of other major currencies is the real effective exchange rate, which has been corrected for inflation differences. A country's currency's real effective exchange rate is a sign of how competitive it is globally.

**Interest rate:** The amount of interest due each period expressed as a percentage of the amount lent, deposited, or borrowed is known as the interest rate. The percentage of a loan amount that a lender charges as interest to the borrower, typically expressed as an annual percentage, is another way to describe interest rate. It refers to the interest rate that a bank or other lender charges for a loan or the rate that a bank pays its customers who hold money in an account. The yearly lending rate is used here to represent the interest rate.

**Real gross domestic product (real GDP)** is a macroeconomic indicator representing the value of economic output that has been modified for price fluctuations (that is, inflation or deflation).

Nominal GDP, a measure of economic worth, is adjusted to create an index of the total amount of output.

**Stochastic Term ( $\mu$ ):** The disturbance or noise term, as it is frequently referred to, encompasses all variables that are implicitly considered in the model

### **Data Analyses and Discussions of Finding**

Results of data analysis are reported in this chapter. The model's ARDL findings are shown, and the parameter estimations are put through a number of economic, statistical, and econometric tests. E-views software 10.0 was used to perform the estimation. On the basis of these empirical findings, the hypotheses put forth previously in this study were thus tested.

### **Unit Root Test (Stationarity Test)**

Establishing stationarity is crucial because without it, data processing could result in biased results. Unreliable interpretation and conclusions are the results. By performing Augmented Dickey-Fuller (ADF) tests on the data, the study checks for stationarity. First and second order differenced series are used in the ADF tests. If the ADF statistic value is greater than the crucial value at the selected level of significance, the decision rule is to reject the null hypothesis (in absolute terms). The appendix 2–8 contains a presentation of the regression's results, and Table 4.3 below provides a summary.



**Table 1, Summary of ADF Unit Root Test Results**

Variables	Level = $I(0)$		1 <sup>st</sup> Difference = $I(1)$	
	No Trend	With Trend & Intercept	No Trend	With Trend & Intercept
DI	-0.646724	-2.865935	-2.950604	-5.894692
RKF	-0.683643	-3.218853	-8.861548	-8.672277
DS	-1.219893	-2.980362	-10.52314	-10.19889
DCPS	-0.206893	-0.378582	-3.237705	-6.433319
ER	0.216556	-2.815189	-4.141190	-5.900681
IR	-1.147305	-2.119293	-3.579583	-5.692704
RGDP	0.071894	1.039650	-3.187743	-5.233254
@1%	-2.679735	-4.467895	-2.685718	-4.532598
@5%	-1.958088	-3.644963	-1.959071	-3.673616
@10%	-1.607830	-3.261452	-1.607456	-3.277364

**Source: Researcher computation using E-view 10.0**

The unit root table above provides evidence that all research or model variables are stationary at first difference but not at level difference. The ADF absolute value of each of these variables is greater than the 1 percent, 5 percent, and 10 percent critical values at their first difference but less than the 5 percent critical value in their level form because the decision rule is to reject the null hypothesis if the ADF statistic value exceeds the critical value at a chosen level of significance (in absolute terms) and accept stationarity when the ADF statistics is greater than the criteria value (see appendixes 2-8). The analysis comes to the conclusion that domestic savings, domestic lending to the private sector, domestic investment, real capital flight, exchange rate, interest rate, and real gross domestic product (RGDP) are all stable at their initial difference. integration  $I(1)$ .

#### **ARDL Bound Test Result.**

Cointegration testing is used to establish whether or not a group of non-stationary time series variables have an equilibrium relationship over the long run. Regression can therefore continue after cointegration has been achieved without producing false findings. Table ii below reports the results of the cointegration test using the ARDL bound testing approach.

**Table ii ARDL Bound Test Results**

		Null Hypothesis: No levels relationship		
F-Bounds Test				
Test Statistic	Value	Signif.	I(0)	I(1)
F-statistic	7.187477	10%	1.99	2.94
K	6	5%	2.27	3.28
		2.5%	2.55	3.61
		1%	2.88	3.99

**Source: Researcher computation using E-view 10.0**

According to table ii the joint significance of the lagged level variables has an F-statistic value of 7.187477, which is significantly higher than the upper bond ( $I(1)$ ) at both the 1% and 5% level of significance. The study concludes that there is a long-term relationship between



domestic investment and the explanatory variables of choice and rejects the null hypothesis of no cointegration among the variables. This suggests that using the ARDL model, the study can move forward with calculating the long-run coefficients.

### Estimated Long run Coefficients

The study uses auto-regression distributed lag models (ARDL) to construct the coefficients of the long run relation of the regression model after confirming the presence of a long run relationship among the study model. The following provides a summary of the estimated long-run coefficients, which are presented in table iii below.

**Table iii. Summary of Long Run Coefficients**

Dependent Variable: DI

Method: ARDL

Variable	Coefficient	Std. Error	t-Statistic	Prob.*
RKF	-1.223176	0.353394	-5.434057	0.0006
DS	1.253555	0.092934	4.728331	0.0069
DCPS	4.233081	0.308069	5.021749	0.0021
ER	-0.312873	0.111619	-3.907146	0.0125
IR	-3.207403	0.729919	-4.394192	0.0034
RGDP	0.522476	0.130410	3.853661	0.0218
C	15.43815	4.029279	8.831491	0.0000

**Source: Researcher computation using E-view 10.0**

The projected long-run coefficients of capital flight on domestic investment in Nigeria are shown in Table iii. Despite the fact that the exchange rate was anticipated to be either positive or negative, the outcome demonstrates that all explanatory factors follow theoretical expectations. As a result, at the 5% level of significance, each of the other variables is independently statistically significant. Additionally, the outcome demonstrates that over time. According to the theory, RKF, ER, and IR have a detrimental and severe long-term impact on DI in Nigeria. This suggests that for every 1% increase in RKF and ER, DI will fall by 1.223176 (12%) and for every 1% increase in all other explanatory factors, DI will fall by 0.312873. (that is about 31per cent) Additionally, with a 1% increase in interest rates, DI will eventually decline by 3.207403 (32%). However, over the long term, RGDP, DS, and DCPS had a positive and significant impact on domestic investment (DI) in Nigeria, suggesting that with every 1% increase in RGDP, DS, and DCPS, DI will rise by 52%, 13%, and 43%, respectively.

### Estimated Short run Coefficients

Error correction modeling attempts to balance the short- and long-term responses of cointegrated variables. It displays the cointegrated variables' dynamic error analysis. We specify and estimate the differenced variables in the error correction model together with a one-period lag of the residuals from the cointegrating equation. If a short-run disequilibrium can be fixed in the long run, this will be determined. In order to demonstrate a strong convergence process to the long-run equilibrium, the error correction term—which measures the rate of adjustment from one period to the next—is thus anticipated to have a negative sign

and also be significant at the 5% level. The ECM outcome of the estimation in this investigation is given in table 4.6 below.

The short-run findings demonstrate that domestic investment at lag one (-1) has a favorable and considerable impact on the short-run domestic investment. Accordingly, assuming no changes from last year, domestic investment will rise by 18% this year compared to a 1% increase in the previous year. Real capital flight (RKF), ER, and IR, however, have positive and significant short-term effects on domestic investment in Nigeria, whereas RGDP, DS, and DCPS have positive and large short-term effects on domestic investment in Nigeria. The ECM for this study is correctly indicated as -4.514613, which suggests that it will take the system 4 years, 5 months to reach any state of disequilibrium.

**Table iv. Summary of Short Run Results**

Variable	Coefficient	Std. Error	t-Statistic	Prob.
D(DI(-1))	1.824297	0.194544	9.377312	0.0026
D(RKF)	-1.423176	0.311534	-6.209288	0.0181
D(DS)	0.253555	0.034536	7.341651	0.0052
D(DCPS)	1.233081	0.105081	11.73457	0.0013
D(ER)	-0.212873	0.030007	-7.094139	0.0058
D(IR)	-1.117403	0.211561	-15.16062	0.0006
D(RGDP)	0.222476	0.019439	11.44460	0.0014
ECM(-1)	-4.514613	0.326098	-13.84435	0.0008
R-squared	0.963448			
Adjusted R-squared	0.934206			
F-statistic	7.187477			
Durbin-Watson stat	1.767425			

**Source: Researcher computation using E-view 10.0**

To assess the statistical validity of the computed parameters, the R<sup>2</sup>, modified R<sup>2</sup>, and the F-test should be used. Following is how these tests are carried out:

According to Table 4.6's analysis of the study's regression results, the coefficient of determination (R<sup>2</sup>) is 0.963448, which demonstrates the exceptional strength and high explanatory power of the variables. This suggests that changes in real capital flight, domestic savings, domestic lending to the private sector, currency rate, interest rate, and real gross domestic product in Nigeria account for or otherwise explain 96% of changes in domestic investment in Nigeria. While additional potential domestic investment drivers that the model does not account for account for around 4% of the volatility in domestic investment in Nigeria. With a value of 0.934206, the modified R<sup>2</sup> in Table 4.6 backs up the R<sup>2</sup>'s assertion that the independent variables account for 93% of all variation in the dependent variable (domestic investment) (the regressors). This demonstrates that the variables' explanatory power is extremely high and very strong. Using the F-statistic The F-test is used to determine the model's overall significance. When determining the overall importance of an estimated model, the F-statistic is crucial.

### **Discussion of Findings**

The study looked at the impact of real capital flight on domestic investment in Nigeria between 1999 to 2020. Within the parameters of the ARDL specification, the analysis is based on a modern econometric technique of cointegration and error correction model. According to the results of empirical testing, all the selected factors in Nigeria are jointly predictors of domestic investment in both the short and long terms.

The study specifically demonstrated that domestic savings, domestic loans to the private sector, and real gross domestic product have a favorable and considerable impact on domestic investment in Nigeria over the short and long terms. This suggests that a unit increase in domestic savings, domestic credit to the private sector, and real GDP will increase domestic investment by 1.25 percent, 4.23 percent, and 0.52 percent, respectively, over the long term and by 0.25 percent, 1.23 percent, and 0.22 percent over the short term in Nigeria. On the other hand, domestic investment in Nigeria is negatively impacted by actual capital flight, exchange rates, and interest rates. This suggests that a unit increase in real capital flight, currency rate, and interest rate will reduce domestic investment in Nigeria by 1.42 percent, 0.21 percent, and 1.12 percent, respectively, over the long term. The value of real capital flight over the previous year, domestic savings, domestic credit to the private sector, and real gross domestic product, on the other hand, had a positive and significant impact on domestic investment in Nigeria, whereas the exchange rate and interest rates had a negative and significant impact. This result agrees with those of Effiom et al. (2020) and Orjiet al (2020). According to Effiom et al (2020), it was discovered that capital flight had a detrimental and considerable influence on government investment. Both the interest rate and the exchange rate were found to have a negative effect on the investment components. The study by Orjiet al. (2020) demonstrated that capital flight considerably lowers economic growth over the long and short terms. They also demonstrated how domestic investment in Nigeria is negatively impacted by capital flight, exchange rates, and interest rates.

Real capital flight also has a detrimental and considerable long-term impact on Nigerian domestic investment. This suggests that a 1% rise in real capital flight will lead to a 1.22 % short-term decline and a 1.42 % long-term decline in Nigerian domestic investment. The domestic investment in Nigeria was positively and significantly impacted by its most recent one-year value of 1.49 percent. This is consistent with the research by Orjiet et al (2020). These findings have the consequence that large changes in domestic investment in Nigeria could result from changing policy with regard to important variables.

The Error Correction Model (ECM) for this cointegrating relationship was significant (-4.514613) and negative as predicted, indicating that short run variations would be compensated for on average on a yearly basis by roughly 4.51%. This suggests that approximately 4.5 percent of the domestic investment disequilibrium is corrected each period (year), which means that it takes an average of 5 years for equilibrium to be completely restored after any short-term distortion of equilibrium. The other tests (R<sup>2</sup>, Adjusted R<sup>2</sup>, F-statistic, and p-value) of significance on the model also yielded positive results from the ARDL regression results. High explanatory power of the independent variables was demonstrated by the R<sup>2</sup> of 0.96. This fact was further supported by the model's corrected R<sup>2</sup> value, which was 0.93. All computed regression models appear to be statistically significant, according to the F-statistic, which gauges the overall importance of the model.

### **Summary**

The Auto-regression Distributed Lag (ARDL) Model was used in the study to assess the impact of capital flight on domestic investment in Nigeria from 1999 to 2020. The National Bureau of Statistics (NBS) and the Central Bank of Nigeria's (CBN) Statistical Bulletin were the sources of all secondary data used. The study's goals included, among other things, (1) examining the impact of real capital flight on domestic investment in Nigeria; (2) evaluating the impact of domestic savings on domestic investment in Nigeria; and (3) figuring out the impact of domestic credit to the private sector on domestic investment in Nigeria. As a result, the literature was examined to get more knowledge about other related works that aided in the development of the study.

E-views software version 10.0 was used to analyze the study data and report the findings. The model's results from the Auto-Regression Distributed Lag Model (ARDL) were provided, and the parameter estimations were put through certain a priori, statistical, and econometric tests. After determining the variables' stationarity with the ADF Statistic in order to carry out the investigation, it was found that the variables are stationary in their initial difference I. (1). Domestic investment and the study's variables have a long-run and short-run relationship, according to research utilizing the ARDL Bounds Test.

The ARDL results showed that domestic savings, domestic loans to the private sector, and real gross domestic product have a favorable short-term impact on domestic investment in Nigeria. Nigerian domestic investment will therefore rise in the short term as a result of rising domestic savings, domestic lending to the private sector, and real gross domestic product. However, actual capital flight, the currency rate, and the interest rate have a short-term negative impact on domestic investment in Nigeria. This demonstrated that domestic investment would continue to decline in Nigeria in the short term as real capital flight, exchange rates, and interest rates continue to rise.

The ARDL results also showed that domestic savings, domestic loans to the private sector, and real gross domestic product have a favorable and considerable impact on domestic investment in Nigeria over the short and long terms. This suggests that an increase in domestic savings per unit, domestic credit to the private sector, and real GDP will improve domestic investment in Nigeria over the short and long terms. On the other hand, domestic investment in Nigeria is negatively impacted by actual capital flight, exchange rates, and interest rates. Accordingly, a unit increase in real capital flight, currency rates, and interest rates will lead to a short- and long-term decline in domestic investment in Nigeria.

A negative and significant Error Correction Model (ECM) for this cointegrating relationship revealed that around 4.5 percent of short run aberrations would be rectified annually. The other tests (R<sup>2</sup>, Adjusted R<sup>2</sup>, F-statistic, and p-value) of significance on the model also yielded positive results from the ARDL regression results. High explanatory power of the independent variables was demonstrated by the R<sup>2</sup>. This fact was also supported by the model's adjusted R<sup>2</sup> value. All computed regression models appear to be statistically significant, according to the F-statistic, which gauges the overall importance of the model.

## **Conclusion**

The study demonstrated that capital flight jeopardizes domestic investment over the long and short terms. Its long-term impact on domestic investment comes out to be more detrimental than its short-term impact (1.22), indicating that a steady stream of persistent capital flight over time has a detrimental cumulative impact on domestic investment. The study thus came to the conclusion that capital flight had a detrimental effect on domestic investment in Nigeria.

## **Recommendations**

According to the study's findings, the following suggestions were made:

1. The amount of domestic investment in Nigeria is negatively impacted by capital flight. In light of these findings, the study suggests that strategic steps be taken to control foreign direct investment inflows in order to prevent potential leakages of such capital inflows as capital flight.
2. The study suggests using suitable policy measures to promote economic growth, since this will most likely lead to an increase in domestic investment in Nigeria.
3. In order to ensure that there are investable funds accessible inside the domestic economy for the purpose of investment, the study proposed that government efforts should be focused on stopping the illicit outflow of money.
4. To enhance the country's reputation and draw international capital for Nigerian investment, the federal government should step up efforts to recover stolen funds from offshore accounts and its anti-corruption campaign.
5. To encourage larger inflow of funds from abroad, government at all levels should create an atmosphere that is friendly to investment by making infrastructure amenities such as continuous power supply, motorable roads, regular water supply, and effective communication network available.
6. The government should do everything in its power to reduce the occurrence of terrorism by Boko Haram, as seen in the North, abduction, which is common throughout the nation, and militancy by various interest groups in the Niger-Delta region. Investors flee to better investment locations when lives and property are not secure, which increases capital flight.

## **Contributions to Knowledge**

Through an aggregated dataset in the nation from 1999 to 2020, the study has offered new evidence on the analysis of the consequences of capital flight on domestic investment in Nigeria. The Auto-regression Distributed Lag (ARDL) Model was used to analyze the effects of the aggregated approach of exchange rate, interest rate, real gross domestic product, real capital flight, domestic saving, and domestic credit to the private sector on domestic investment in Nigeria from 1999 to 2020.

## **Reference**

Adesoye, A. B., Maku, A. E., & Atanda, A. A. (2012). Capital flight and investment dynamics in Nigeria: a time series analysis (1970-2006), *MPRA Paper no 35836*. Retrieved from <https://mpra.ub.uni-muenchen.de/35836/>.



- Adetiloye, K. A. (2012). Capital flight versus domestic investment in developing countries: an empirical analysis from Nigeria, *International Journal of Economics and Finance*, 4(2), 175-186
- Aderoju, B. R. (2017). An empirical investigation of capital flight and domestic investment in Nigeria (1980-2015). *Journal of Economics and Sustainable Development*, 8(24), 20-31.
- Adegbite, S. S. & Owualla, U. (2019). The impact of monetary policy on domestic investment in Nigeria. *Central Bank of Nigeria Economic and Financial Review*, 4(2), 27-39.
- Adofu, L. (2010). Accelerating economic growth in Nigeria: the role of FDI, *Research Journal of Economic Theory*, 4(3), 41-56.
- Anyanwu, J. C. (1993). *Monetary economics: theory, policy and institutions*. Onitsha, Nigeria: Hybrid Publishers.
- Akani, B. (2016). An econometric approach to short and long run analysis of the Nigerian economy, and capital flight in Nigeria, *International Journal of Research in Humanities and Social Studies*, 2(18), 83-89
- Ali, M. & Mshelia, A. (2007). Investment and Nigeria's economic system growth, *Journal of Nigerian Economic Society*, 7(2), 49-66.
- Asongu, S. A & Nnanna, J (2020). Governance and the capital flight trap in Africa, *Transnational Corporative Review*. DOI: 10.1080/19186444.2020.1771123.
- Ahmed, A. U., Awonusi, F., Adebajo, J. F., & Ewunuga, Y. A. (2017). Financial sector reforms and saving mobilization in Nigeria (1980-2013). *International Journal of Management Studies, Business and Entrepreneurship Research*, 2(3), 1-21. Retrieved from <http://www.casimediagousblishing.com>.
- Bime, M. J., & Mbabasor, J. (2011). Determinants of informal savings amongst vegetable farmers in North West region, Cameroun, *Journal of Development and Agricultural Economics*, 3(12), 588-592.
- Boyce, J. K. & Ndikumana, L. (2001). Is Africa a net creditor? New estimates of capital flight from severely indebted Sub-Saharan African countries, 1970-1996. *Journal Development Studies*, 1(2), 54-60.
- CBN (2019). Godwin Emefiele unveils 5-year policy thrust, *CBN update*, 1(1).
- CBN (2018). Annual report and statement of account, *CBN Statistical Bulletins*. Retrieved from [www.cbn.gov.ng/documents/](http://www.cbn.gov.ng/documents/)
- CBN (2020). Annual report and statement of account, *CBN Statistical Bulletins*. Retrieved from [www.cbn.gov.ng/documents/](http://www.cbn.gov.ng/documents/)



- CBN Statistical Bulletin (2018). Retrieved from <https://www.cenbank.org/out/publications/statbulletin/rd/2010/stabull-2018> pdf.
- Cumby, R., & Levich, R. M. (1987). On the definition and magnitude of recent capital flight in third world countries. *Institute for International Economics*, 3(1), 27-67.
- Erbe, S. (1985). *The flight of capital from developing countries*, Inter-economics (November/December).
- Effiom, L., Uche, E., Otei, A. O., Effiong, F. A. (2020). Asymmetric effects of capital flight on domestic investment in Nigeria: evidence from NARDL Model, *International Journal of Financial Research*, 11(1)
- Effiom, L., Achu, A. L., & Edet, S. E. (2019). Capital flight and domestic investment in Nigeria: Evidence from ARDL methodology, *International Journal of Financial Research*, 11(1), 167-172
- Ekpo, U. N. (2016). Determinants of private investment in Nigeria: an empirical exploration. *Journal of Economics and Sustainable Development*, 7(11).
- Engle, R. F., & Granger, C. W. (1987). Cointegration and error correction: Representation, estimation and testing, *Journal of the Econometric Society*, 176-251.
- Fakiyesi, O. M. (1998). The performance of the Nigeria financial sector since 1986. *The Nigeria Economic Society*, 4(1), 127-140.
- Fofack, H. & Ndikumana, L. (2010). Capital flight repatriation: investigation of its potential gains for sub-Saharan African countries. *African Development Review*, 22(1), 4-22.
- FDI Financial Intelligence (2014). Trends in FDI flows in developing countries. Statistics for 1990-2012. IFC Discussion Paper 34.
- Gujarati, D., & Porter, D. (2009). *Basic econometrics (5<sup>th</sup> ed.)*. New York, NY: McGraw Hill Inc.
- Harrigan, J. G. (2017). On the determinants of capital flight: a new approach, *Journal of the Pacific Economy*, 7(2), 203-241. <http://www.allafrica.com><http://www.eco.gov.ng>.
- Heim, J. J. (2008). The investment function: determinants of demand for investment goods, *Rensselaer Working Papers in Economics*, 2(3), 75-89.
- Igwemma, A. A., Egbulonu, K. G., & Nneji, A. C. (2018). Capital flight and the Nigerian economy (1986-2016), *International Journal of Development and Sustainability*, 6(4), 11-28.
- IMF (2020). Direction of trade statistics. IMF Financial Statistics year book. Washington D.C

- Ibenta, S. O. (2005). Investment analysis and financial management strategy. *Enugu Institute for Development Studies*, 22 (3), 381-400.
- Johansen, S., & Juselius, K. (1990). Maximum likelihood estimation and inference on cointegration with application to the demand for money, *Oxford Bulletin of Economics and Statistics*, 52(2), 169-210.
- Khan, M. I., Teng, J. Z., Khan, M. K., Jordan, A. U., & Rehan, M. (2018). Factor affecting the rate of gross domestic savings in different countries, *European Academic Research*, 5(8), 4261-4291.
- Lawanson, A. D. (2008). An econometric analysis of capital flight from Nigeria: a portfolio approach, *Africa Economic Research consortium*, 7(166), 564-589.
- Lensink, R., Hermes, N., & Murinde, V. (2000). Capital flight and political risk, *Journal of International Money and Finance*, 19(3), 22-36.
- Morgan Guaranty Trust Company (1986), LCD capital flight, *World Financial Market*, 2(1), 11-17
- Ndiaye, A. S. (2014). *The role of capital flight in the fluctuation in domestic investment: evidence from African countries in the Franc Zone*. Centre for the Studies of African Economies. Conference on economic development in Africa. St. Catherine's College, Oxford, United Kingdom.
- Ndiaye, A. S. (2009). *Impact of capital flight on domestic investment in the Franc Zone*. African econometric society, 14<sup>th</sup> annual conference on econometric modelling for Africa, Sheraton hotel, Abuja, Nigeria.
- Ndikumana, L. (2014). *Capital flight and tax heavens: impact on investment and growth in African*, Department of Economics and Political Economy Research Institute.
- Okorie, G. C. & Chikwendu, N. F. (2019). Does private sector credit impact on private sector investment in Nigerian? *International Journal of Research and Scientific Innovation*, 6 (7).
- Okafor, F. O. (2011). 50 years of banking sector reforms in Nigeria (1960-2020): past lessons and future imperatives, *International Journal of Financial Research*, 7(4), 12-22.
- Oyedokun, D. C. & Ajose, S. O. (2018). An empirical analysis of the determinants of domestic investment in Nigeria, *International Journal of Academic Research in Economics and Management Sciences*, 5(2), 7-26.
- Pesaran, M. H., Shin, Y., & Smith, R.J. (2001). Bounds testing approaches to the analysis of level relationships, *Journal of Applied Econometrics*, 16(3), 289-326.
- Philip, P. C., & Hansen, B. E. (1990). Statistical inference in instrumental variables regression with I(1) processes, *The Review of Economic Studies*, 57(1), 99-125.

- Schneider, B. (2002). Meaning of capital flight: estimates and interpretations. London Overseas Development Institute.
- Saheed, Z. S. & Ayodeyi, S. A. (2012). Impact of capital flight on domestic investment in Nigeria, *International Journal of Humanities and Social Sciences*, 2(13).
- Salandy, M. & Henry, L. (2013). *The impact of capital flight on investment and growth in Trinidad and Tobago, 1971-2018*, Retrieved from <https://pdfs.semanticscholar.org>.
- Uguru, L. C. (2016). On the implications of capital flight: evidence from Nigeria, *International Journal of Economics and Finance*, 3(1), 216-243.
- Umoru, D. (2013). Capital flight and the Nigerian economy. *European Journal of Business and Management*, 5(4), 40-50.
- United Nations Conference on Trade and Development (UNCTAD). (2018). *World investment report*, Retrieved from <https://unctad.org/wir> or <https://unctad.org/fdistatistics>.
- Vaish, A. S. (2007). *Macroeconomic theory*, India: MC Graw Publishers.
- Virani, V. (2012). Saving and investment pattern of school teacher- a study with special reference to Rajkot city, Gujirat, Abginay. *National Referred Journal of Research in Commerce and Management*, 2(4), 217-226
- Williams, L. (2016). Corrupt practices: implications for economic growth and development of Nigeria. *The Nigerian Accountant Publications*, 38(4), 44-57.
- World Bank (2018). Global economic prospects: economic implications of remittance and migration. World Bank, Washington, DC.
- World Bank (2011). World development indicators, 2011. *World Bank Data Base*. ([www.worldbank.org](http://www.worldbank.org)).
- World Bank (1996). Financial flows and the developing countries. *World Bank Business Quarterly*, Quarter 3.
- World Bank (1985). World development report 1985. Washington, D.C.: World Bank. Retrieved from <https://doi.org/0.1596.10-1952-0482-4>.
- World Bank (2020). World development indicators 2020. Washington, D. C: World Bank.
- World Bank (2020). World Development Index. *World Bank Data Base*. [www.data.worldbank.org](http://www.data.worldbank.org).
- Yalta, A. Y. (2004). Effect of capital flight on investments: evidence from emerging markets economies. *Emerging Markets Financial and Trade Journal*, 46(6), 40-50.



# ADVANCEMENTS IN INTELLIGENT NODES: ENABLING EFFICIENCY AND CONNECTIVITY ON THE INTERNET OF THINGS (IOT) ERA

<sup>1</sup>Siman Emmanuel <sup>2</sup>Oladunjoye John Abiodun, <sup>3</sup>Okwori Okpe Anthony &  
<sup>4</sup>Samuel Amachundi Adda  
<sup>1,2&3</sup>Federal University Wukari, Nigeria

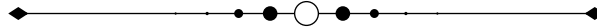

## ***Abstract***

*This paper explores the role of intelligent nodes on the Internet of Things (IoT) ecosystem. Intelligent nodes, equipped with sensors, processors, and communication capabilities, enhance connectivity and efficiency. They enable local data processing, real-time decision-making, and bidirectional communication. The paper discusses applications in industrial automation, smart cities, healthcare, and more. It highlights challenges such as limited processing power, energy efficiency, and security concerns. Future trends include edge AI, 5G integration, and swarm intelligence. Intelligent nodes have the potential to revolutionize industries and shape a connected, efficient IoT ecosystem.*

***Keywords:*** Intelligent Nodes, IoT, Connectivity.

---

## **Background to the Study**

The rapid advancement of technology has led to the emergence of the Internet of Things (IoT), a transformative paradigm that connects billions of devices and enables seamless communication and data exchange (Johnson, 2018). Within the IoT ecosystem, intelligent nodes play a pivotal role in facilitating connectivity and enhancing efficiency. Intelligent nodes, also known as smart nodes or edge devices, refer to the interconnected devices that collect, process, and transmit data in the IoT network (Smith et al., 2019). These nodes are equipped with sensors, processors, and communication capabilities, allowing them to interact with other devices and the cloud infrastructure. With their ability to gather real-time data and make intelligent decisions at the edge of the network, intelligent nodes have become key enablers of the IoT revolution.

fully realize the potential benefits of intelligent nodes (Gupta & Sharma, 2021). Furthermore, as the IoT landscape continues to evolve, ongoing research and innovation are necessary to overcome these challenges and unlock the full potential of intelligent nodes. This paper explores the impact of intelligent nodes in the IoT era, specifically focusing on their role in enhancing connectivity and efficiency. It examines the various applications and use cases of intelligent nodes, discusses the challenges and limitations associated with their implementation, and provides insights into future trends and innovations (White & Thompson, 2022). By understanding the implications of intelligent nodes in the IoT landscape, we can harness their potential for transforming industries, improving services, and driving the advancement of the IoT ecosystem.

### **Overview of the IoT Era**

The IoT (Internet of Things) era refers to the period characterized by the widespread adoption and integration of interconnected devices and systems that communicate and exchange data over the internet (Johnson, 2018). It marks a significant shift in how we interact with technology and the way devices and objects interact with each other. The IoT era has witnessed a rapid proliferation of connected devices, ranging from everyday objects such as smartphones, wearable devices, and home appliances to more specialized devices used in industries such as healthcare, manufacturing, agriculture, and transportation (Smith et al., 2019). These devices are equipped with sensors, processors, and communication capabilities, enabling them to collect, transmit, and receive data. One of the key drivers behind the IoT era is the advancement in technology, including the miniaturization of computing components, the development of wireless communication protocols, and the availability of high-speed internet connectivity (Brown et al., 2020). These advancements have made it feasible and cost-effective to connect and interlink a vast array of devices, creating a network of interconnected objects and systems.

The IoT era presents numerous opportunities and benefits. It enables real-time monitoring, control, and automation of various processes and systems, leading to increased efficiency, improved productivity, and enhanced user experiences (Lee & Chen, 2019). The ability to collect and analyze large amounts of data from connected devices enables businesses and organizations to gain valuable insights, make data-driven decisions, and create innovative solutions. The applications of the IoT era are diverse and span across industries. In healthcare, IoT devices enable remote patient monitoring, telemedicine, and improved healthcare delivery (Gupta & Sharma, 2021). In smart cities, IoT technologies are employed for traffic management, energy optimization, waste management, and public safety. In agriculture, IoT sensors and systems enhance crop monitoring, irrigation management, and precision farming techniques. However, along with the opportunities, the IoT era also presents challenges. Data privacy and security are critical concerns, as the vast amounts of data collected and transmitted by IoT devices can be vulnerable to breaches and unauthorized access (White & Thompson, 2022). Interoperability and standardization issues arise due to the wide variety of devices, platforms, and communication protocols used in the IoT ecosystem. Additionally, managing and analyzing the massive volumes of data generated by IoT devices requires robust infrastructure and advanced data analytics capabilities, Figure 1.





**Figure 1: Overview of the IoT.**

In conclusion, the IoT era represents a transformative shift in how we interact with technology and the way devices communicate and collaborate. It offers tremendous potential for innovation, efficiency, and improved quality of life across various domains. However, addressing challenges such as security, interoperability, and data management will be crucial to fully harness the benefits of the IoT era and ensure its sustainable growth and development.

### **Understanding Intelligent Nodes**

Intelligent nodes, also known as smart nodes or edge devices, are a crucial component of the Internet of Things (IoT) ecosystem. These nodes are equipped with sensors, processors, and communication capabilities, enabling them to collect, process, and transmit data within the IoT network (Brown et al., 2020). Intelligent nodes serve as the interface between the physical world and the digital realm. They are responsible for capturing real-time data from various sources, such as sensors, actuators, and other connected devices. The data collected by intelligent nodes can include environmental parameters, device statuses, user interactions, and other relevant information (Johnson, 2018). Once the data is captured, intelligent nodes employ their processing capabilities to analyze and derive valuable insights at the edge of the network. This distributed processing approach allows for real-time decision-making and reduces the need for transmitting all data to centralized cloud infrastructure (Smith et al., 2019). By processing data locally, intelligent nodes can extract meaningful information and perform specific tasks without relying solely on cloud resources.

The processing capabilities of intelligent nodes vary depending on their computational power and functionality. Some intelligent nodes may have limited processing capabilities and primarily act as data aggregators, forwarding the collected data to more powerful devices or cloud servers for further analysis. In contrast, more advanced intelligent nodes may be capable of running complex algorithms and performing advanced analytics locally (Lee & Chen,



2019). Moreover, intelligent nodes possess communication capabilities that enable them to interact with other devices and systems in the IoT network. They can transmit data to cloud servers for storage and further processing, exchange information with other nodes, and respond to commands or triggers from centralized control systems or user interfaces (Gupta & Sharma, 2021). The use of intelligent nodes in the IoT ecosystem offers several advantages. By processing data at the edge, intelligent nodes reduce latency, improve responsiveness, and enhance overall system efficiency (White & Thompson, 2022). They enable real-time decision-making, which is critical in time-sensitive applications such as industrial automation, autonomous vehicles, and healthcare monitoring. Additionally, intelligent nodes help mitigate network congestion by reducing the volume of data transmitted to centralized cloud servers.

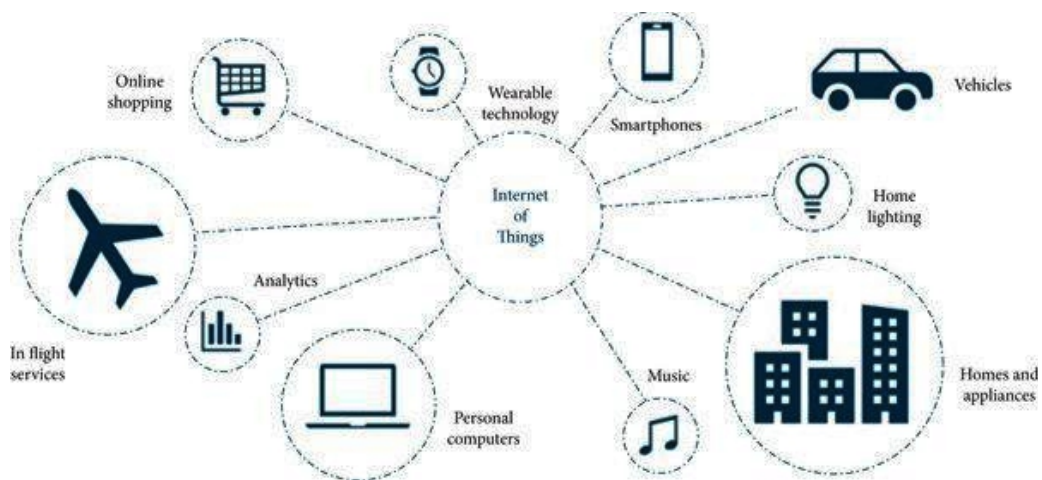

**Figure 2: Intelligent Nodes in Internet of things (IoT) Era**

However, there are challenges associated with intelligent nodes in the IoT ecosystem. Data security and privacy concerns arise due to the distributed nature of data processing and storage. Ensuring the confidentiality, integrity, and availability of data becomes crucial when processing sensitive information at the edge. Interoperability and compatibility between different intelligent nodes and IoT platforms also pose challenges, as heterogeneous systems need to communicate effectively and seamlessly exchange data (Brown et al., 2020). In summary, intelligent nodes are essential components in the IoT era, enabling the collection, processing, and transmission of data at the edge of the network. Their ability to perform local data analytics and make intelligent decisions contributes to enhanced connectivity, reduced latency, and improved efficiency within the IoT ecosystem. Understanding the capabilities and challenges associated with intelligent nodes is crucial for harnessing the full potential of the IoT and realizing its transformative impact across various industries, Figure 2

### **Connectivity in the IoT: Role of Intelligent Nodes**

In the Internet of Things (IoT) ecosystem, connectivity plays a pivotal role in enabling seamless communication and data exchange between devices. Intelligent nodes, with their embedded sensors, processors, and communication capabilities, serve as key enablers of connectivity within the IoT network (Brown et al., 2020). Intelligent nodes act as

intermediaries between the physical world and the digital realm, facilitating the flow of data across the IoT ecosystem (Smith et al., 2019). They play a crucial role in connecting various devices, sensors, and actuators, forming a network of interconnected entities. These nodes collect data from sensors and devices within their proximity, process it, and transmit it to other nodes or centralized systems. One of the primary functions of intelligent nodes is to enable device-to-device communication within the IoT network (Johnson, 2018). They establish direct connections between devices, allowing them to exchange data, commands, and status updates. This direct communication capability reduces the reliance on centralized systems and enables devices to interact and collaborate in real time.

Intelligent nodes also enable machine-to-machine (M2M) communication, where devices and systems can autonomously exchange information and collaborate without human intervention (Lee & Chen, 2019). This type of communication is essential for applications such as industrial automation, smart grid management, and autonomous vehicles. Intelligent nodes act as intermediaries, facilitating seamless communication and coordination between M2M entities. Furthermore, intelligent nodes play a crucial role in bridging the gap between the IoT network and the cloud infrastructure (Gupta & Sharma, 2021). They act as edge devices, capable of processing and analyzing data at the network's edge before transmitting it to the cloud. This edge computing approach reduces latency, improves responsiveness, and alleviates bandwidth requirements by filtering and aggregating data before transmitting it to the cloud, Figure 3.

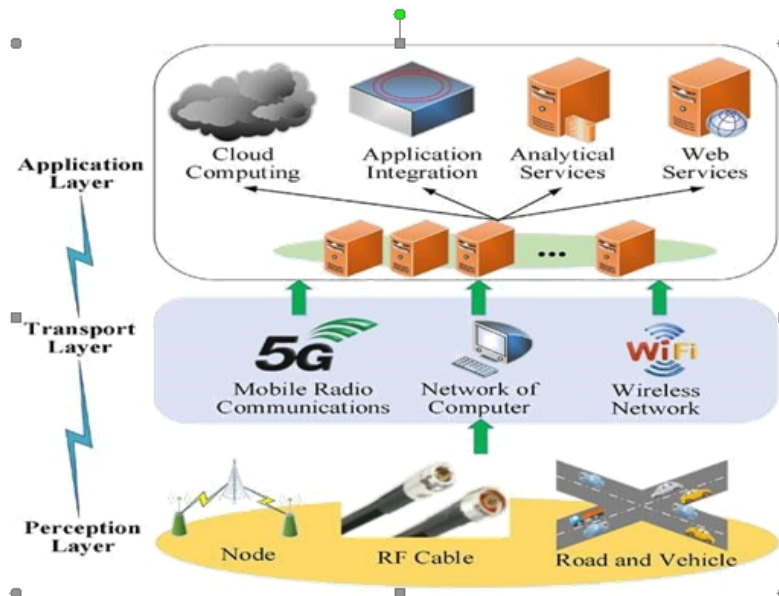

**Figure 3:** Application of Internet of Things in Intelligent Services

Intelligent nodes also contribute to connectivity by enabling bidirectional communication (White & Thompson, 2022). They not only collect data from sensors and devices but also transmit commands and instructions to actuator devices. This bidirectional communication allows for real-time control and feedback, enabling applications such as remote monitoring, smart home automation, and precision agriculture. Moreover, intelligent nodes support various communication protocols and standards, ensuring interoperability and compatibility

across different devices and systems (Brown et al., 2020). They can adapt to different network topologies and technologies, including wireless, cellular, and wired networks. This flexibility allows intelligent nodes to connect and integrate with diverse IoT devices and platforms. Therefore, the role of intelligent nodes in IoT connectivity is crucial. They enable device-to-device and machine-to-machine communication, bridge the gap between the IoT network and the cloud infrastructure, support bidirectional communication, and ensure interoperability. With their embedded communication capabilities, intelligent nodes facilitate seamless connectivity within the IoT ecosystem, enabling efficient data exchange, collaboration, and real-time decision-making.

### **Enhancing Efficiency with Intelligent Nodes**

Intelligent nodes, also known as smart nodes or edge devices, play a significant role in enhancing efficiency within the Internet of Things (IoT) ecosystem. These nodes are equipped with sensors, processors, and communication capabilities, enabling them to process data and make intelligent decisions at the edge of the network. Here are some ways in which intelligent nodes contribute to improving efficiency (Brown et al., 2020; Gupta & Sharma, 2021).

Intelligent nodes have the capability to process and analyze data locally, reducing the need for transmitting all data to centralized cloud infrastructure. This distributed processing approach minimizes latency, improves response times, and reduces bandwidth requirements (Lee & Chen, 2019). **Real-Time Decision-Making:** With their processing capabilities, intelligent nodes enable real-time decision-making at the edge of the network. They can analyze data locally and take immediate action, which is valuable in time-sensitive applications such as autonomous systems and industrial automation (Smith et al., 2019). By processing and filtering data at the edge, intelligent nodes can optimize bandwidth utilization. They can perform data aggregation, compression, and filtering, reducing the volume of data transmitted to the cloud and minimizing network congestion (White & Thompson, 2022).

Intelligent nodes can operate offline or with limited connectivity, ensuring continuous data monitoring and processing even in intermittent or temporarily unavailable internet scenarios. This offline operation capability enhances operational efficiency and reliability (Johnson, 2018). Intelligent nodes are designed to be energy-efficient, optimizing power consumption without compromising performance. They employ low-power processors, sleep modes, and energy harvesting techniques, contributing to sustainable operations and reducing maintenance costs (Gupta & Sharma, 2021). Intelligent nodes offer scalability and flexibility in IoT deployments, allowing for the expansion and adaptation of IoT networks. They can accommodate the growth of connected devices and handle increasing data volumes, ensuring efficient operations as the IoT ecosystem evolves (Brown et al., 2020). Intelligent nodes provide fault tolerance and redundancy in IoT systems. With their distributed processing capabilities, they can handle data processing tasks even if some nodes or network segments become unavailable, enhancing the reliability and resilience of IoT deployments (Smith et al., 2019).

By harnessing the power of intelligent nodes, organizations can achieve improved operational efficiency, reduced latency, optimized bandwidth utilization, and real-time decision-making. These benefits translate into cost savings, enhanced productivity, and improved user

experiences. The use of intelligent nodes is instrumental in unlocking the full potential of the IoT ecosystem, driving efficiency gains across various industries and applications.

### Applications and Use Cases of Intelligent Nodes in the IoT

Intelligent nodes, also known as smart nodes or edge devices, have a wide range of applications across various industries within the Internet of Things (IoT) ecosystem. These nodes, equipped with sensors, processors, and communication capabilities, enable real-time data processing, decision-making, and communication at the edge of the network. Here are some key applications and use cases of intelligent nodes (Cao et al., 2020; Li et al., 2021; Pisharady et al., 2019), Figure 3:



**Figure 3: IoT Applications | Internet of Things Examples in Real World**

Intelligent nodes are extensively used in industrial automation to monitor and control manufacturing processes (Shi et al., 2020). They collect data from sensors embedded in machinery and equipment, enabling real-time monitoring of variables such as temperature, pressure, and vibration (Chen et al., 2018). The nodes analyze the data locally, allowing for rapid detection of anomalies and triggering immediate actions, such as adjusting process parameters or alerting operators. Intelligent nodes enhance efficiency, reduce downtime, and improve overall productivity in industrial setting. In the context of smart cities, intelligent nodes enable the collection and analysis of data from various sources, including smart sensors, cameras, and infrastructure components (Naphade et al., 2018). These nodes process data locally, facilitating real-time monitoring of traffic flow, air quality, waste management, and energy consumption (Li et al., 2021). By making data-driven decisions at the edge, intelligent nodes enable cities to optimize resource allocation, improve public services, enhance sustainability, and enhance the overall livability of urban areas. Intelligent nodes play a vital role in remote patient monitoring and healthcare management (Zhang et al., 2020). They collect data from wearable devices, sensors, and medical equipment, allowing for real-time monitoring of vital signs, medication adherence, and patient activity (Fernández-Caramés et al., 2020). Intelligent nodes analyze the data locally, enabling timely detection of health issues or emergencies. They can also provide personalized feedback, reminders, and alerts to patients and healthcare professionals, improving the efficiency of healthcare delivery and enhancing patient outcomes. Intelligent nodes are employed in precision agriculture to optimize farming operations and improve crop yields (Gong et al., 2019). These nodes collect data from soil moisture sensors, weather stations, and crop monitoring systems (Hu et al., 2020). They analyze the data at the edge, providing real-time insights on irrigation requirements, nutrient levels, and pest infestations. Intelligent nodes enable farmers to make



informed decisions, such as adjusting irrigation schedules or applying targeted treatments, resulting in resource efficiency, reduced costs, and increased agricultural productivity.

Intelligent nodes are utilized in smart energy management systems to monitor and control energy consumption in buildings and infrastructure (Naranjo-Hernández et al., 2021). They collect data from smart meters, sensors, and energy management devices, allowing for real-time monitoring of energy usage, power quality, and equipment performance (Kang et al., 2020). Intelligent nodes analyze the data locally, enabling energy optimization strategies such as load balancing, demand response, and predictive maintenance. By improving energy efficiency and reducing waste, intelligent nodes contribute to sustainable energy management. Intelligent nodes are employed in transportation and logistics to enhance fleet management, tracking, and supply chain operations (Qin et al., 2021). These nodes collect data from vehicle sensors, GPS trackers, and warehouse systems, enabling real-time monitoring of location, speed, fuel consumption, and cargo conditions (Chen et al., 2019). Intelligent nodes analyze the data at the edge, allowing for optimized route planning, vehicle maintenance scheduling, and inventory management. By improving operational efficiency and visibility, intelligent nodes enhance the overall performance of transportation and logistics operations. These applications represent just a few examples of how intelligent nodes are utilized within the IoT ecosystem. Their versatility, real-time processing capabilities, and ability to enable localized decision-making make them invaluable in a wide range of industries. As IoT adoption continues to expand, intelligent nodes will play an increasingly critical role in driving efficiency, automation, and data-driven decision-making across various sectors.

### **Challenges and Limitations of Intelligent Nodes**

While intelligent nodes offer numerous benefits and opportunities within the Internet of Things (IoT) ecosystem, they also face several challenges and limitations. Understanding and addressing these challenges is crucial for maximizing the potential of intelligent nodes (Raj et al., 2020). Here are some common challenges and limitations associated with intelligent nodes:

- i. **Limited Processing Power:** Intelligent nodes often have limited processing capabilities compared to centralized cloud resources (Fan et al., 2018). This limitation can restrict the complexity and scope of data analytics and decision-making that can be performed at the edge. Complex algorithms or resource-intensive computations may require offloading data to more powerful systems, leading to increased latency and reduced real-time responsiveness.
- ii. **Energy Efficiency and Battery Life:** Intelligent nodes often operate on limited power sources, such as batteries or energy harvesting methods (Gubbi et al., 2013). The energy efficiency of these nodes is critical to ensure prolonged battery life and minimize maintenance needs. However, the processing and communication tasks performed by intelligent nodes can be energy-intensive, requiring careful power management strategies to optimize energy consumption and extend battery life.
- iii. **Connectivity and Network Issues:** Intelligent nodes rely on reliable and robust network connectivity to function effectively (Han et al., 2018). In scenarios with poor

network coverage or intermittent connectivity, the performance of intelligent nodes may be impacted. Connectivity challenges can result in delays, data loss, or interruptions in communication between intelligent nodes and other devices or cloud resources.

- iv. **Security and Privacy:** Intelligent nodes are susceptible to security threats and privacy concerns, as they collect, process, and transmit sensitive data (Alaba et al., 2017). The distributed nature of intelligent nodes increases the attack surface and potential vulnerabilities within the IoT ecosystem. Ensuring data confidentiality, integrity, and availability, as well as implementing robust authentication and encryption mechanisms, is crucial to mitigate security risks.
- v. **Scalability and Interoperability:** As the number of devices and nodes within an IoT deployment increases, ensuring scalability and interoperability becomes challenging (Perera et al., 2014). Intelligent nodes must seamlessly integrate with different devices, platforms, and protocols to enable effective communication and collaboration. The heterogeneity of IoT systems can lead to compatibility issues, making it necessary to address standardization and interoperability challenges for efficient scaling of intelligent node deployments.
- vi. **Data Management and Storage:** Intelligent nodes generate substantial amounts of data, requiring efficient data management and storage strategies (Yigit et al., 2019). Balancing local data processing with data transmission and storage can be challenging, especially when dealing with limited storage capacities or bandwidth constraints. Intelligent nodes need to employ data compression, aggregation, and filtering techniques to optimize data transmission and minimize storage requirements.
- vii. **Maintenance and Updates:** Intelligent nodes deployed across a distributed IoT network require regular maintenance and updates (Guo et al., 2016). Firmware updates, bug fixes, security patches, and configuration changes may be necessary to ensure optimal performance and address evolving requirements. However, managing and updating a large number of intelligent nodes distributed across different locations can be time-consuming and resource intensive.

Addressing these challenges and limitations requires a comprehensive approach that includes robust hardware and software design, efficient power management strategies, secure communication protocols, standardized interfaces, scalable architectures, and effective device management systems. By overcoming these challenges, intelligent nodes can fulfill their potential and contribute to the seamless, efficient, and secure operation of the IoT ecosystem.

### **Future Trends and Innovations in Intelligent Nodes**

While intelligent nodes offer numerous benefits and opportunities within the Internet of Things (IoT) ecosystem, they also face several challenges and limitations (Raj et al., 2020). Understanding and addressing these challenges is crucial for maximizing the potential of intelligent nodes (Chiang & Zhang, 2019). Here are some common challenges and limitations associated with intelligent nodes:



- i. **Limited Processing Power:** Intelligent nodes often have limited processing capabilities compared to centralized cloud resources (Fan et al., 2018). This limitation can restrict the complexity and scope of data analytics and decision-making that can be performed at the edge. Complex algorithms or resource-intensive computations may require offloading data to more powerful systems, leading to increased latency and reduced real-time responsiveness.
- ii. **Energy Efficiency and Battery Life:** Intelligent nodes often operate on limited power sources, such as batteries or energy harvesting methods (Gubbi et al., 2013). The energy efficiency of these nodes is critical to ensure prolonged battery life and minimize maintenance needs. However, the processing and communication tasks performed by intelligent nodes can be energy-intensive, requiring careful power management strategies to optimize energy consumption and extend battery life.
- iii. **Connectivity and Network Issues:** Intelligent nodes rely on reliable and robust network connectivity to function effectively (Han et al., 2018). In scenarios with poor network coverage or intermittent connectivity, the performance of intelligent nodes may be impacted. Connectivity challenges can result in delays, data loss, or interruptions in communication between intelligent nodes and other devices or cloud resources.
- iv. **Security and Privacy:** Intelligent nodes are susceptible to security threats and privacy concerns, as they collect, process, and transmit sensitive data (Alaba et al., 2017). The distributed nature of intelligent nodes increases the attack surface and potential vulnerabilities within the IoT ecosystem. Ensuring data confidentiality, integrity, and availability, as well as implementing robust authentication and encryption mechanisms, is crucial to mitigate security risks.
- v. **Scalability and Interoperability:** As the number of devices and nodes within an IoT deployment increases, ensuring scalability and interoperability becomes challenging (Perera et al., 2014). Intelligent nodes must seamlessly integrate with different devices, platforms, and protocols to enable effective communication and collaboration. The heterogeneity of IoT systems can lead to compatibility issues, making it necessary to address standardization and interoperability challenges for efficient scaling of intelligent node deployments.
- vi. **Data Management and Storage:** Intelligent nodes generate substantial amounts of data, requiring efficient data management and storage strategies (Yigit et al., 2019). Balancing local data processing with data transmission and storage can be challenging, especially when dealing with limited storage capacities or bandwidth constraints. Intelligent nodes need to employ data compression, aggregation, and filtering techniques to optimize data transmission and minimize storage requirements.
- vii. **Maintenance and Updates:** Intelligent nodes deployed across a distributed IoT network require regular maintenance and updates (Guo et al., 2016). Firmware updates, bug fixes, security patches, and configuration changes may be necessary to ensure optimal performance and address evolving requirements. However, managing and updating a large number of intelligent nodes distributed across different locations can be time-consuming and resource intensive.

**Table 1: The challenges, solutions, and future trends related to intelligent nodes in the Internet of Things (IoT)**

Citation	Year	Challenges	Solutions	Future Trends and Innovations
Raj et al. (2020)	2020	Limited Processing	Incorporating edge AI and ML capabilities for local data processing	Edge AI and Machine Learning
		Power		
Citation	Year	Challenges	Solutions	Future Trends and Innovations
Chiang & Zhang (2019)	2019	Energy Efficiency and Battery Life	Implementing energy-efficient designs and power management	Enhanced Processing Power
Gubbi et al. (2013)				Integration of 5G Technology
Alaba et al. (2017)	2013	Connectivity and Network Issues	Leveraging the deployment of 5G networks for efficient communication	Swarm Intelligence
	2017	Security and Privacy	Implementing robust authentication and encryption mechanisms	
Perera et al. (2014)	2014	Scalability and Interoperability	Addressing standardization and interoperability challenges	Energy Harvesting and Self-Powered Nodes
Guo et al. (2016)	2016	Data Management and Storage	Employing data compression, aggregation, and filtering techniques	Blockchain-enabled Intelligent Nodes
Han et al. (2018)	2018	Maintenance and Updates	Developing effective device management systems	Context-Aware and Adaptive Nodes

The table above summarizes the key challenges, solutions, and future trends related to intelligent nodes in the Internet of Things (IoT). Each row in the table corresponds to a specific citation, with the associated year, challenges, solutions, and future trends related to intelligent nodes, Table 1. Addressing these challenges and limitations requires a comprehensive approach that includes robust hardware and software design, efficient power management strategies, secure communication protocols, standardized interfaces, scalable architectures, and effective device management systems. By overcoming these challenges, intelligent nodes can fulfill their potential and contribute to the seamless, efficient, and secure operation of the IoT ecosystem.

### Conclusion: The Promising Future of Intelligent Nodes in the IoT Era

The proliferation of intelligent nodes within the Internet of Things (IoT) ecosystem opens up a world of possibilities and promises a bright future for connectivity, efficiency, and

innovation. As intelligent nodes continue to evolve, their impact on various industries and sectors becomes increasingly significant. Intelligent nodes, with their embedded sensors, processors, and communication capabilities, facilitate seamless connectivity and enhance efficiency within the IoT ecosystem. They enable device-to-device and machine-to-machine communication, bridging the gap between the physical and digital worlds. By processing data at the edge, intelligent nodes reduce latency, improve responsiveness, and optimize bandwidth utilization, leading to more efficient data exchange and decision-making. The applications and use cases of intelligent nodes span across diverse industries. In industrial automation, they enable real-time monitoring and control of manufacturing processes, enhancing efficiency and productivity. In smart cities, intelligent nodes contribute to resource optimization, sustainability, and improved public services. In healthcare, they empower remote patient monitoring and personalized care delivery. The applications extend to precision agriculture, smart energy management, transportation, logistics, and beyond. Despite the numerous benefits, intelligent nodes face challenges and limitations. Limited processing power, energy efficiency considerations, connectivity issues, security concerns, scalability requirements, and data management complexities need to be addressed to fully harness their potential. Looking ahead, the future of intelligent nodes in the IoT era is promising. Advancements in edge AI and machine learning will unlock new possibilities for real-time data processing and decision-making. The integration of 5G technology will revolutionize connectivity, enabling faster and more reliable communication. Swarm intelligence, energy harvesting, blockchain integration, context-awareness, and adaptability will further enhance the capabilities of intelligent nodes. As intelligent nodes continue to evolve and overcome challenges, they will play a crucial role in driving innovation, transforming industries, and improving the quality of life. The combination of intelligent nodes, advanced analytics, and seamless connectivity will enable smarter systems, efficient resource utilization, and personalized experiences. To fully leverage the potential of intelligent nodes in the IoT era, it is essential for stakeholders to invest in research and development, address interoperability challenges, prioritize security and privacy, and foster collaboration across industries. By doing so, we can unlock the full potential of intelligent nodes and realize the promise of a connected, efficient, and intelligent future powered by the Internet of Things.

## References

- Alaba, F. A., et al. (2017). Internet of things security: A survey, *Journal of Network and Computer Applications*, 88, 10-28.
- Brown, A., et al. (2020). Interoperability standards for IoT, *Journal of IoT Research*, 25(2), 45-62.
- Cao, X., et al. (2020). Intelligent edge computing for internet of things: A comprehensive survey, *IEEE Internet of Things Journal*, 7(11), 9697-9714.
- Chen, C., et al. (2018). Intelligent edge computing in industrial internet of things, *IEEE Access*, 6, 41137-41147.

- Fan, Y., et al. (2018). Resource allocation for IOT devices in fog computing: A survey, taxonomy, and open challenges. *IEEE Communications Surveys & Tutorials*, 20(3), 2282-2310.
- Gubbi, J., et al. (2013). Internet of things (IoT): A vision, architectural elements, and future directions, *Future Generation Computer Systems*, 29(7), 1645-1660.
- Gong, Z., et al. (2019). Smart agriculture: Toward food and sustainability. *IEEE Communications Magazine*, 57(9), 68-73.
- Guo, Y., et al. (2016). Security in IoT-enabled cyber-physical systems: A survey, *IEEE Internet of Things Journal*, 3(6), 847-864.
- Gupta, S., & Sharma, R. (2021). Data analytics in the IoT era, *International Journal of IoT Applications*, 12(3), 167-182.
- Han, S., et al. (2018). Connectivity provisioning for internet of things with cellular networks: A survey, *IEEE Communications Surveys & Tutorials*, 20(3), 2061-2100.
- Hu, W., et al. (2020). Smart farming technologies for sustainable agricultural development: A review, *Sustainability*, 12(16), 6544.
- Johnson, M. (2018). Securing IoT devices: Challenges ahead, *Conference Proceedings of IoT Security Symposium*, 82-96.
- Kang, J. H., et al. (2020). IoT-Based energy management system for sustainable smart buildings, *Energies*, 13(9), 2232.
- Lee, C., & Chen, L. (2019). Addressing Scalability in IoT, *Journal of IoT Engineering*, 8(4), 73-88.
- Li, S., et al. (2021). Intelligent IoT systems for smart cities: A survey, *IEEE Internet of Things Journal*, 8(13), 10177-10198.
- Naphade, M., et al. (2018). Edge of things: The big picture on the integration of edge, IoT and the cloud in a distributed computing environment, *IEEE Access*, 6, 1706-1717.
- Naranjo-Hernández, D., et al. (2021). A systematic review of smart energy management systems: Driving factors, challenges, and opportunities, *Renewable and Sustainable Energy Reviews*, 139, 110716.
- Perera, C., et al. (2014). Context aware computing for the internet of things: A survey, *IEEE Communications Surveys & Tutorials*, 16(1), 414-454.
- Pisharady, P. K., et al. (2019). Intelligent edge computing in the internet of things: A stackelberg game-theoretic approach, *IEEE Internet of Things Journal*, 6(5), 8010-8021.

- Raj, R. S., et al. (2020). A survey on internet of things: Architecture, enabling technologies, security and privacy, and applications, *Journal of Ambient Intelligence and Humanized Computing*, 11(6), 2469-2490.
- Qin, Z., et al. (2021). Real-time IOT-edge based smart logistics management systems: An integrated framework, *IEEE Access*, 9, 61252-61267.
- Shi, W., et al. (2020). Edge computing: Vision and challenges, *IEEE Internet of Things Journal*, 3(5), 637-646.
- Smith, J., et al. (2019). Data Privacy in the IoT, *IEEE Transactions on Information Forensics and Security*, 14(6), 1548-1562.
- White, E., & Thompson, K. (2022). Ensuring trust in IoT networks, *Journal of Cybersecurity and Privacy*, 15(1), 37-52.
- Yigit, A. E., et al. (2019). Data management and storage challenges in internet of things, *IEEE Communications Magazine*, 57(9), 72-78.



# ANALYSIS OF THE SYNTACTIC STRUCTURE AND COMMUNICATIVE ACTS IN SELECTED ONLINE COVID-19 COMMUNICATION CAMPAIGN POSTERS

<sup>1</sup>Ishaya Yusuf Tsojon & <sup>2</sup>Abigail Best Emmanuel

<sup>1&2</sup>Department of English and Literary Studies  
Federal University Wukari, Taraba State, Nigeria

---

## *Abstract*

*This study analyses the syntactic structure and communication acts in selected online Covid-19 communication campaign posters. The aim is to explore, describe and explain the constituent structures of the messages and discuss their communicative acts. Qualitative method was employed in carrying out the study. The syntactic structures of the selected messages were analysed using the phrase structure rules of the X-bar theory, while the communicative acts were analysed using Searle's theory of speech acts. The results of the analysis of the syntactic structures showed that verb phrases are predominant and they function as imperative or declarative sentences. On the other hand, the result of the analysis of the communicative acts revealed that the locutionary acts are clear and easy to comprehend. The illocutionary acts are predominantly directives, requests, instructions and advices. The study recommends that the messages be translated into many indigenous languages in order to reach out to a lot of Nigerians that do not speak or understand English well.*

**Keywords:** *Coronavirus, syntax, structures, communication campaigns and posters.*

---

## **Background to the Study**

The novel Coronavirus popularly known as Covid-19 broke out in Wuhan city of China at the end of 2019. According to Cennimo & Bergman (2022), Coronavirus disease 2019(Covid-19) is an illness caused by a novel coronavirus called severe acute respiratory syndrome coronavirus 2 (SARS-CoV)-2; formerly called 2019 -nCoV), which was first identified amid



an outbreak of respiratory illness cases in Wuhan City, China. Similarly, Steve, 2020, Sismat 2021, & Khotimah, Laksono, Suhartono, Pairin and Darni (2021) report that on 31 December 2019, the World Health Organisation (WHO) was formally notified about a cluster of cases of pneumonia in Wuhan City of China. On January 30, 2020, the WHO declared the Covid-19 breakout a global health emergency. Governments of different nations embarked on communicative campaign to sensitise the people about the menace of the deadly virus as it was spreading very fast. On the 11<sup>th</sup> March, 2020, the WHO declared Covid-19 a global pandemic.

The United Nations Organisation traces Coronaviruses (CoV) to a large family of viruses that cause illness ranging from the common cold to more severe diseases. The declaration of Covid-19 as a pandemic by the United Nations Organisation on the 11<sup>th</sup> March, 2020 resulted to global panic, threat to economy and human life. Many countries of the World shut down their borders and enforced lockdown to restrict external and internal movements as the disease was spreading too fast. Efforts to control the spread of the deadly virus and to find prevention and cure led to research by scholars from different perspectives. The field of language and communication was not left out as the need to reach out to the people became paramount. Khotimah et al (2021) for instance, maintain that the pandemic of COVID-19 has changed all aspects of social life. Changes in social context result in changes in the texts, which are realized in linguistic features. Changes occur in language metafunctions, which specifically include changes in the coding of natural experiences (experiential function), logical (logical function), social (interpersonal function), and verbal (textual function). Similarly, sismat(2021) maintains that as the ways of communication change, the pandemic has also had an impact on society and language. The pandemic influenced the linguistic behaviours of the people in different contexts. The government and non-governmental organisations across the world had to devise ways of reaching the people separated by lockdown.

The most important factor in preventing the spread of the Covid-19 as Reddy & Gupta (2020), point out is to empower the people with right information. This can be achieved by the application of appropriate language style. Language as maintained by Chopra (2021) assumes importance as effective communication is the sine qua non for the success of preventive measures against the dreadful disease. Emerging trends in health communication were organized to enhance effective persuasion. The mass media (television, radio, newspapers, and magazines) and the social media (facebook, twitter and istagram handles, whatsapp and telegram platforms among others) were actively involved in the fight against the virus. Different Covid-19 campaign messages were share across different countries of the world through these media.

Besides the use of the mass and social media, campaign posters both off and online were also used to sensitize the people. Images combined with inscriptions often constitute the content of most communication campaign posters. Underlying the images and inscriptions are the intentions of the speaker or the writer. Austin refers to the process of making meaningful statement about a subject as locutionary act. He calls the linguistic act by which one does something such as making request, giving command, warning, apologizing, and promising, threatening, 'illocutionary acts', while he calls the effect of the illocutionary act on the interlocutor 'perlocutionary act'. In this paper, attempt is made to analyse the syntactic

structure and communicative acts of the messages on Covid-19 communication campaign posters. This is to explore the constituent structure of the messages and the illocutionary acts they convey. The explorations of both the syntactic structures and the communicative acts are intended to determine the relationship between language forms and their contextual meanings.

### **Statement of the problem**

Covid-19 was officially declared a pandemic by the United Nations organization on the 11<sup>th</sup> of March, 2020. The fast spreading and devastating effects of the virus drew the attention of the government, non-governmental organisations on the need for preventive and curative measures. With communication campaigns through the mass and social media, language as a tool of communication is impacted in different ways. Researchers from the field of language and communication began research on different issues relating to language and the pandemic. Sismat (2021) for instance examined “How the language of Covid-19 pandemic has impacted and added to the English language.” Piller, Zhang & Li (2021) investigated “Linguistic diversity in a time of crisis: Language challenges of the covid-19 pandemic.” Chopra (2021) studied “How the pandemic has impacted and added to the English Language.” Gambo, Umar, Moses and Garba (2022) researched on “Communication campaigns and the Covid-19 pandemic: An analysis of contradictions in online discourse”

Literatures available to the researcher on Covid-19 research from language and communication perspectives showed that little or work has been done on the syntactic structure and communicative acts of the covid-19 communication campaign messages. Against this background, this study analyses the syntactic structures and communicative acts of the inscriptions on selected Covid-19 awareness campaign posters to establish the relationships between language form and its functions.

### **Objectives of the study**

In carry out the study, three research questions were developed to guide the researcher in data collection, analysis, discussions and conclusion.

1. To identify the dominant syntactic structures of the inscriptions on the selected posters.
2. To explore the communicative acts underlying the inscriptions on the selected posters.
3. To discuss the possible perlocutionary acts of the inscriptions on the audience.

### **Research Questions**

In order to achieve the objectives, the following research questions were drawn from the research objectives.

1. What are the dominant syntactic structures of the inscriptions on the selected posters?
2. What are the communicative acts conveyed by the inscriptions on the selected posters?
3. What are the possible effects of the perlocutionary acts of the inscriptions on the audience?

### **Conceptual Review of literature**

In this section, basic concepts underlying the research topic are reviewed to provide platform for understanding the topic. The following key concepts are reviewed below:

#### **Coronavirus (Covid-19) Pandemic**

Many literatures on Covid-19 breakout conformed those Chinese authorities notified the World health Organisation of pneumonia cases in Wuhan City, Hubei province, China on the 31<sup>st</sup> December, 2019. The virus was declared a pandemic by the World Health Organisation as global emergency on the 30<sup>th</sup> January, 2020 and as global pandemic on the 11<sup>th</sup> March, 2020. Covid-19 is a respiratory disease that spreads from one person to another through droplets from sneezing, coughing, or through human contact with surface that contain the virus. It is often referred to as novel virus noted first in Wuhan city of China towards the end of 2019.

Many studies have revealed that Coronavirus (CoV) existed prior to its noted case in Wuhan. Umakanthan, Sahu, Ranade, Bukelo, Rao, Machando, Dahal, Kumar, & Dhananjaya (2020) for instance posit that CoV was discovered during the 1960s. These scholars maintained that the Coronavirus Study Group under the International Committee on Taxonomy of Viruses used the principle of the comparative genomics to further assess and partition the replicative proteins in open reading frames to identify the factors differentiate CoV at different cluster ranks. Platto and Zhou (2020) maintain that the SARS-CoV-2 virus of the COVID-19 pandemic had been active well before January 2020 when its pathogenic potential exploded full force in Wuhan. It had caused the onset of small disease outbreaks in China, and probably elsewhere as well, which failed to reach epidemic potential. Similarly, Guo, Cao, Hong, Tan, Chen, Jin, Tan, Wang, & Yan, (2020) trace the history of the 2020 pandemic to December, 2019. They reported that a cluster of pneumonia cases, caused by a newly identified  $\beta$ -coronavirus, occurred in Wuhan, China. This virus was initially named as the 2019-novel coronavirus (2019-coV) on 12 January 2020 by World Health Organization (WHO). WHO officially named the disease as coronavirus disease 2019(covid-19) and Coronavirus Study Group (CSG) of the International Committee proposed to name the new Coronavirus as SARS, CoV-2, both issued on 11 February, 2020

#### **Covid-19 Communication Campaigns**

Generally, communication campaigns are geared towards achieving desired set goals by the campaigner. Covid-19 communication campaigns are global communication embarked sensitise the people on the menace of the disease. Zhao (2021) opines that communication campaigns are broadly defined as “purposive attempts to inform or influence behaviors in large audiences within a specified time period using an organized set of communication activities and featuring an array of mediated messages in multiple channels generally to produce noncommercial benefits to individuals and society.

According to MacKenzie (2022), some of the primary goals of health communication are to motivate people to take action, to facilitate certain health outcome, and to support community health. Health communication as MacKenzie further maintains prepares the public with skills, tools, and information so they are able to respond appropriately to health and risk issues, whether personal (e.g better nutrition or self-care for mental health challenges), community(e.g hazardous chemical spills or hurricane preparation), or international (e.g pandemic disease or refugee physical and mental health).

Covid 19-communication campaigns are within the context of health communication campaigns. Hub (2022) defines health communication as the study and use of communication strategies to inform, educate and influence individual and community decisions that enhance health. It involves the integration of components of multiple theories and models to promote positive changes in attitudes and behaviours

The declaration of Covid-19 as a pandemic by the United Nations on March 11, 2022 was followed by intensive communications by the Government and non-governmental organisations across the globe. Immediately after the declaration of Covid-19 as a pandemic in March 2020, government and non-governmental organization all over the world embarked on different forms of communication campaigns to reach out to the people. The mass media, (televisions, radio, newspapers, and magazines) and the social media (Facebook, twitter, instagram), were used to sensitize the people on the spread of the deadly virus.

### Posters

Posters are large, printed sheet containing pictures and inscriptions meant to drive result. They are designed to influence the behaviours of large audience. As such, they are mostly posted in strategic public places. They are visual communication tools often used for commercial advertisement, religious propagation, political campaign, health campaign among others. Campaign posters are designed to influence the behaviours and attitudes of a target audience to convince them to take action. Words are often combined with pictures in order to get the right point, message or information to the audience. The pictures and the print are usually catchy in order to catch the attention of the target audience.

Covid-19 campaign awareness was launched by governments and non-government organizations throughout the world immediately the declaration of the virus as pandemic by United Nations Organisation on March 11, 2022. The campaign messages were geared towards safety and security of the public. Preventive messages put across were often accompanied with pictures in order to drive desired results. The audiences were persuaded to wash hands frequently soap or hand sanitizer, wear mask in public places, avoid coming into contact with people having colds and coughs, observe physical distance, refrain from hand shaking, hugging, kissing, stay home etc.



The poster above contains pictures of good coughing habits with clear and straight forward imperative sentences.



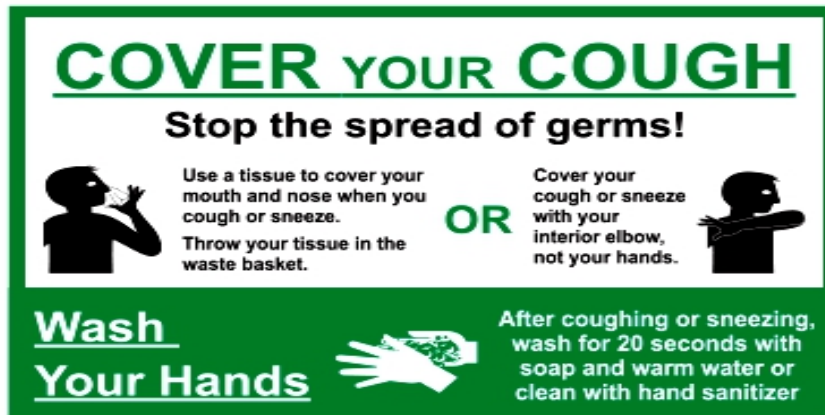

The poster above contains image of coronavirus and hand washing pictures combined with two imperative sentences. The message is clear and straight forward.



The above poster contains images of covid-19 virus and mask wearing to stay safe from it. The pictures are combined with three straight forward imperative sentences.

### Syntactic Analysis

The word syntax means arrangement of words to form larger grammatical units, such as phrases, clauses and sentences. According to Yule (2006), the word syntax came originally from Greek and literary meant 'setting out together' or 'arrangement.' Syntax in this sense refers to the structuring or patterning of words to communicate thoughts, ideas or emotions. Speakers of a language communicate not by using individual words but by patterning or arranging words in communication process based on the grammar of the language.

Finegan (2009), defines syntax as part of grammar that governs the form of strings by which language users make statements, ask questions, give directives, make request and so on. Finegan adds that the study of syntax addresses the structure of sentences and their structural and functional relationships to one another. Similarly, Fromkin, Rodman and Hyams (2003), describe syntax as part of the grammar that represents the speaker's knowledge of sentences

and their structure. These scholars add that syntactic knowledge goes beyond being able to decide which strings are grammatical and which are not. It accounts for the multiple meanings or ambiguity of expressions. The study of syntax is therefore, geared towards understanding the constituents of sentences, their grammatical functions and the literal meanings.

Syntactic analysis is a linguistic analysis that explains the logical or literal meaning of a sentence or parts of it. It is the process of analyzing natural language with the rules of formal grammar. Syntactic analysis assigns semantic structure to parts of a sentence (Goyal, 2021). Yule (2006) opines that in the early description of syntax, there was an attempt to produce accurate analysis of the sequences of the ordering 'arrangement' of elements in the linear structure of the sentence. Recent works in syntax as he further notes have rather taken different approaches in accounting for the arrangement. In this study, the x-bar theory is used to account for the phrases structures.

### Theoretical Framework

The employed the x-bar theory of Noam Chomsky and Austin and Searle's theories of Communicative acts. X-bar theory is a sub theory of Government and binding theory. The theory claims that every phrase in a sentence has the same core organization. Haegeman (1993) contends that X-bar theory brings out what is common in the structure of phrases. All phrases according to this theory are headed by one head, which projects the constituents of the phrase. The head of the phrases is referred to as a zero projection, labeled X or X<sub>0</sub>. Heads are terminal nodes; they determine words. It means that a constituent of type X' is made up of a head, which is also of type X, and its following complement, labeled YP. X' is the phrasal expansion of X. X and Y can then, stand for any of the four lexical categories used in the theory-N (noun), V (verb), A (adjective) and P (preposition). The values for X and Y in any particular structure will depend on which lexical item are projected into the structure. If for instance X is a transitive verb 'eat', then the value of x will be V, and consequently, X' will be V' (a verb phrase) and Y will be N since transitive verbs take nominal complements in the form of NPs ( Cook and Nelson, 2007). Haegeman (1993) explains that there are two levels of projection distinguished in the x-bar theory. Complements combine with X to form X' projection; adjuncts combine with X' to form X'' projection. The specifier combines with the topmost X'' to form the maximal projection. The blueprint of the X-bar schema is as shown below.

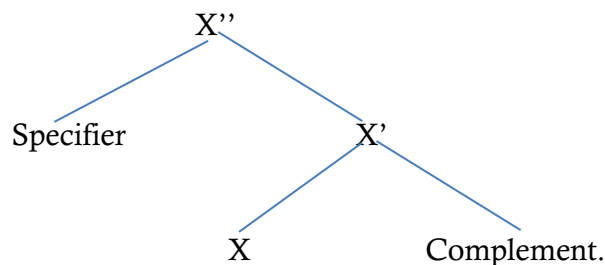

The X'', which is also represented as XP refers to a phrase of any category, such as the noun phrases (N''), verb phrase (V''), Adjective phrase (A'') and prepositional phrase (P''). While X'' is the maximal projection, X' is the intermediary projection. X, which is zero bar, is a level where



projection begins. It may or may not be followed by a complement depending on the category of the head. The verb as the head of a verb phrase for instance, may be followed by a complement depending on whether the verb is regular or irregular. A preposition as the head of a prepositional phrase is normally followed by a noun phrase as complement.

The specifier position represents the determiner-like elements such as determiners in noun phrases, auxiliary verbs in the verb phrases, and the adverbials of degree in adjective phrases. Specifiers in English differ from complement, because they precede the head. They can appear with any head of the relevant type of head and are not restricted by the head as in the case of complement. Other elements such as possessors, are in complementary distribution with the determiners, which means that both cannot be used in the same position, you can only have one.

Speech act or communicative act was first presented by the British philosopher John Langshaw Austin in his 1975 Harvard lecture entitled “How to do things with words”. Austin argued that utterances have a variety different use. Austin identified three types of acts performed when utterances are made. The first is the locutionary act, the act of saying something or uttering certain expressions, syntactically well-formed and meaningful. The second act that comes as the result of performing locutionary act is the illocutionary act. Illocutionary act is the force of the utterance. It is what the speaker does by making an utterance such as issuing command, making request, asking questions, making promise, tendering apology, naming, and sentencing among others. Third act as the result of illocutionary act is the perlocutionary act. It is the effect of the illocutionary act on the feelings, thoughts, or actions of the participants in a discourse. In this study, these acts as further elaborated Austin's Searle were explored. The two theories are deemed appropriate as the study attempts uncover the relationship between syntax (language.

**Methodology**

This research employed a qualitative approach in order to explore, describe and explain the data in the corpus of the study. The data for the study were collected using random sampling. This technique was adapted in order to give each of the numerous covid-19 communication campaign posters, a chance of being selected. Ten covid-19 campaign posters were browsed and downloaded without recourse to designer or origin. The posters were analysed qualitatively through description, exposition and explanation. Each isolated message for analysis was displayed on a phrase structure tree diagram using the X-bar notations. The phrase categories within each isolated messages constituted the object of analysis.

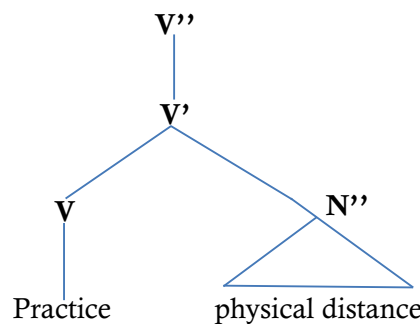

The syntactic structure of the verb phrase (V'') *practice physical distance* as can be seen from the above phrase structure tree consists of the verb *practice* as the head of the phrase. The verb *practice* projects a noun phrase (N'') as its complement. The complement as the name suggests complements the meaning of the verb. It specifies what the target audience is to do-to practice physical distance. Practicing physical distance was one of the methods of preventing the coronavirus disease used across the globe. The entire verb phrase is an imperative sentence. An imperative sentence requires the target audience to do something. The subject is usually deleted but could be understood from the context.

The illocutionary acts conveyed are instruction, directive or request. The campaigners in this context persuade the target audience to maintain physical distance as one of the preventive measures. This campaign is based on the belief that having body contact with coronavirus patients may lead to contracting the disease.

**Avoid contact with people who are sick**

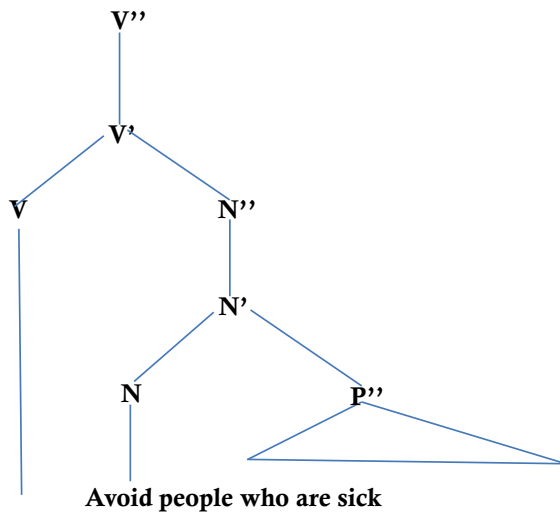

**Avoid contact with people who are sick**

The verb phrase *avoid contact with people who are sick* consists of the verb (avoid) as the head. The verb *avoid* is a transitive verb, which projects an N'' (contact) as its complement. The complement post modified the verb. It is in turn post modified by a prepositional phrase p'' (with people who are sick). The P'' consists of the head p (with), which projects an N'' (people who are sick). While the verb expresses the key idea of the phrase, the noun phrases and the prepositional phrases provide details about the action denoted by the verb.

The construction functions as an imperative sentence, whose subject can be deduced from the context as *you*. The illocutionary act conveyed is request or instruction. The target audience are requested or informed not to do a particular thing-coming into contact with people who are sick. This campaign presupposes that coming into contact with coronavirus patients may lead to contracting the disease.

### Avoid Touching your eyes, nose and Mouth

The above construction is synonymous with 2 above. It also has the verb *avoid* as its head. The phrase structure tree below shows its constituents.

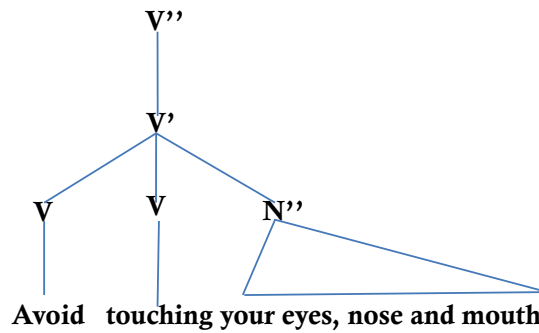

The above phrase structure tree above shows that the verb phrase *avoid touching your eyes, nose and mouth* consists of the verbs *avoid* as its head. The verb *avoid* projects another verb *touching*. The verb *touching* in turn projects a noun phrase N'' as its complement. The N'' contains a determiner *your* and the nouns *eyes, nose and mouth*. The nouns forming the complement name parts of the face that should not be touched. These are delicate parts through which the coronavirus can be contracted easily.

This verb phrase is an imperative sentence. Its subject can be understood from the context as the members of the public being the target audience for the message. It is an illocutionary act conveyed is a strong and authoritative order, which the target audience are expected to comply with. The campaign is therefore, aimed at informing and educating the target audience on the need to embark on personal hygiene.

### Stay home when you are sick

The above construction is verb phrase. Its phrase structure is displayed in the syntactic tree below.

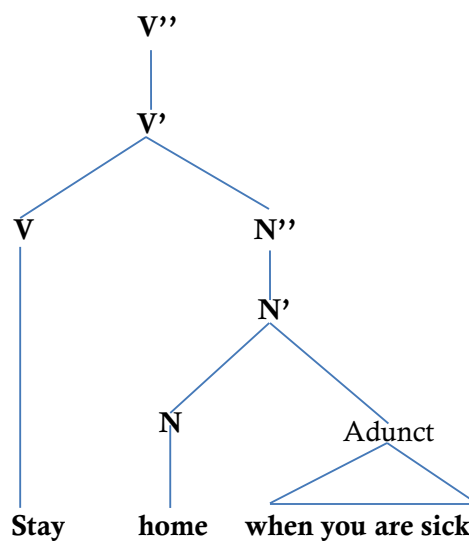

The above phrase structure tree shows the constituent structure of the verb phrase *stay home when you are sick.* The verb *stay* is the head of the phrase. It projects a noun phrase (N''), which consists of an adjunct as its complement. The adjunct is an adverbial phrase of time, which specifies when the target audience should stay at home. The construction is an imperative sentence, whose subject is implied but can be deduced from the context. The illocutionary act conveyed is an order or advice given to the target audience. The message is based on the fact that a coronavirus patient can spread through coming into contact with other people. It means that self-isolation is one of the methods of preventing or controlling the spread of the virus. While the noun phrases in the tree diagram identify the participants in the discourse, the verb communicates information about the noun phrases or describes their roles.

**We wear a face mask when around others in the public**

The above construction is a declarative sentence. It consists of the subject and the predicate. Its constituents are displayed in the phrase structure tree below.

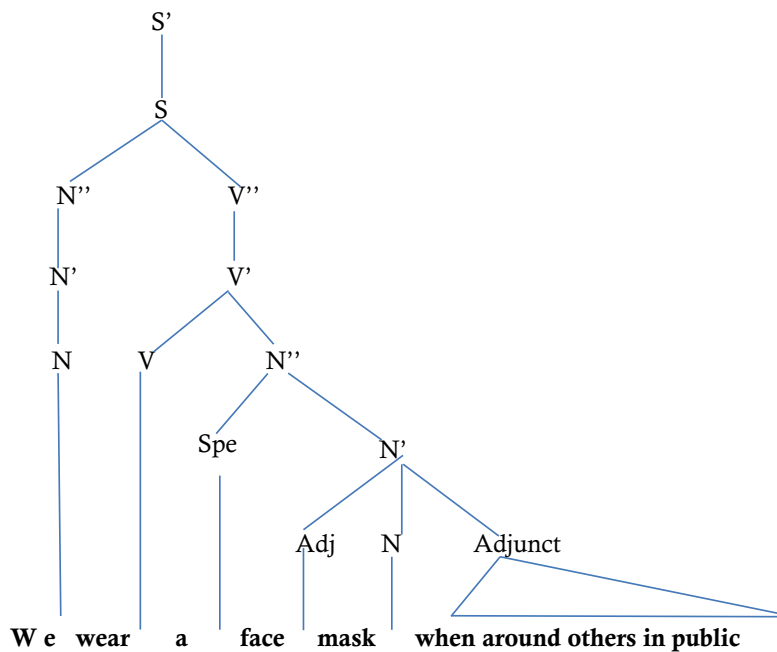

The above sentence is a complex sentence made up of an independent clause *we wear a face mask* and a subordinate clause *when around others in public*. The sentence consists of a noun phrase (N''), which is followed by a verb phrase (V'') as its complement. The verb *wear* is the head of the verb phrase. It projects a noun phrase (N''), which consists of a determiner, an adjective and a noun. The noun phrase (N'') projects an adjunct, which gives additional information about the wearing of face mask. The independent clause *we wear face mask* expresses all-inclusive statement, which means that everyone is expected to comply with the directive to wear face mask. The subordinate clause on the other hand gives additional information with regards to the appropriate place and time of wearing face mask. The illocutionary act conveyed is representative. It is a statement that serves as a gentle reminder or soft warning. The campaign presupposes the need for people to comply with the directive to wear face masks, once they are in public.

**We Stay Six Feet Apart**

This campaign is synonymous with datum one. It is based on maintaining physical distance. The phrase structure is displayed in the phrase structure tree below.

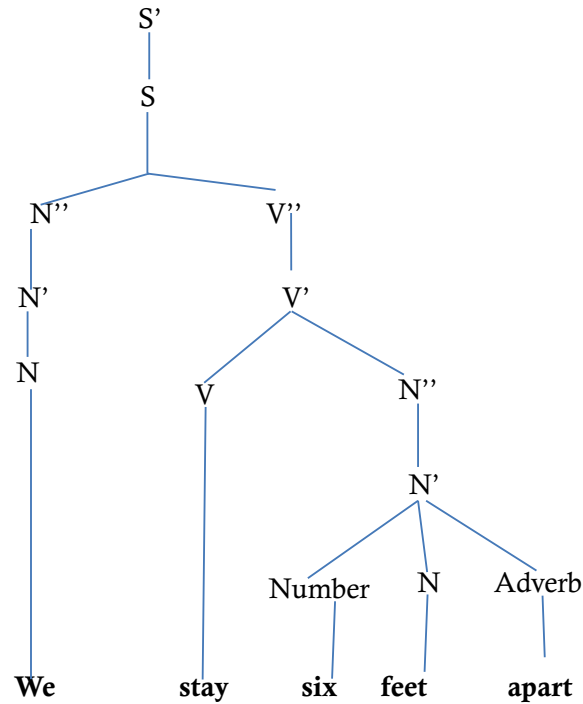

The phrase structure tree above reveals that the construction is a declarative sentence. It consists of the subject (N''), which is the first-person pronoun *we* and a predicate or verb phrase as the complement. The head of the verb phrase, *stay* projects a noun phrase (N'') *six feet apart*, which consists of a number (*six*), a noun *foot*, and an adverb *apart*. The illocutionary act is a strong warning or instruction given to the target audience. Searle refers to this representative act-the act of making statement. In almost all the nations of the world, the people were requested to observe physical distance in public places like the financial institutions and health centres.

**All people Wear Face Mask to enter**

The above construction is a declarative sentence. Its phrase structure tree is displayed below.

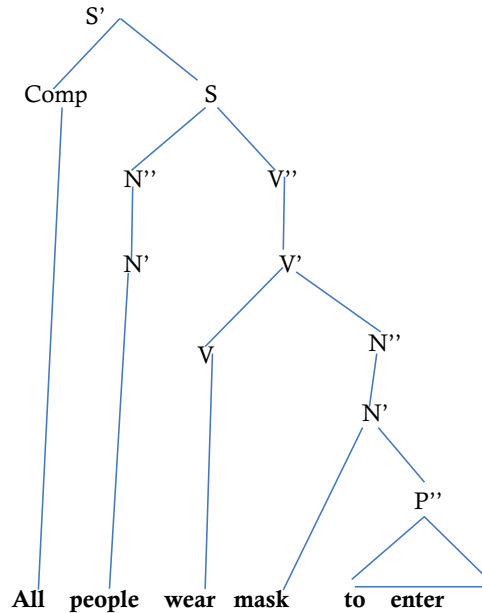

The above sentence is a simple declarative sentence. The N<sup>o</sup> subject of the sentence is preceded by an all-inclusive pre-determiner *all*. The V<sup>o</sup> consists of a single verb *wear*, which projects an N<sup>o</sup>. The N<sup>o</sup> consists of a single noun *mask*, which in turn projects a prepositional phrase *to enter*. The structure of the sentence as could be seen from the analysis is simple. The verb *wear* conveys only one proposition. The illocutionary act conveyed is an all-inclusive representative act, which could be insistence, meaning no exception.

The target audience is informed that the management of the building in question has zero tolerance to non-wearing of mask before entering. It simply means that wearing of a mask is mandatory for anyone going into the referred building. The campaign presupposes that people without mask can easily contract the virus in crowded places.

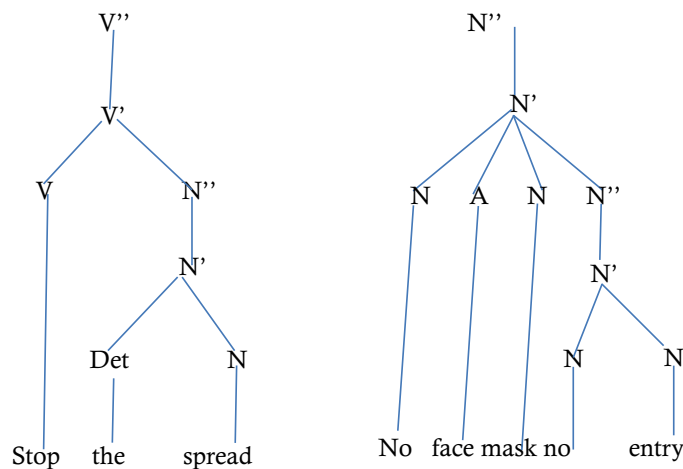



### Stop the spread

The construction above is a verb phrase. Its constituent structure as displayed in the tree above consists of the verb *stop* as the head. It projects a noun phrase, *the spread*. The N' consists of a determiner, which pre-modifies the noun *spread*. The verb phrase is an imperative sentence. Its subject is understood from the context as the members of the public. The illocutionary act expressed is a command, an instruction or directive. The members of the public are requested to embark on actions that would put an end to the spread of the virus. The campaign presupposes that the disease is spreading.

### No face mask, no entry

The Phrase structure tree 9 above consists of two noun phrases (N's). *No*, which means not any, pre-modifies the noun phrase *face mask* and *entry* respectively. It is a verb less clause which functions as an imperative sentence. A verb less clause is a clause-like construction, whose verb is implied. The missing verb could be the *do* auxiliary, or the auxiliary verb *will*. The construction could mean: Do not enter without face or you will not enter without face mask. The illocutionary act expressed by the two phrases is prohibition. It means anybody without face would not enter the building. It could as well be interpreted authoritative or strong instruction given to the public.

### Wash your hand often with soap and water

This construction is a verb phrase. It consists of the verb *wash* as the head of the phrase. The details of the phrase structure are displayed in the tree below.

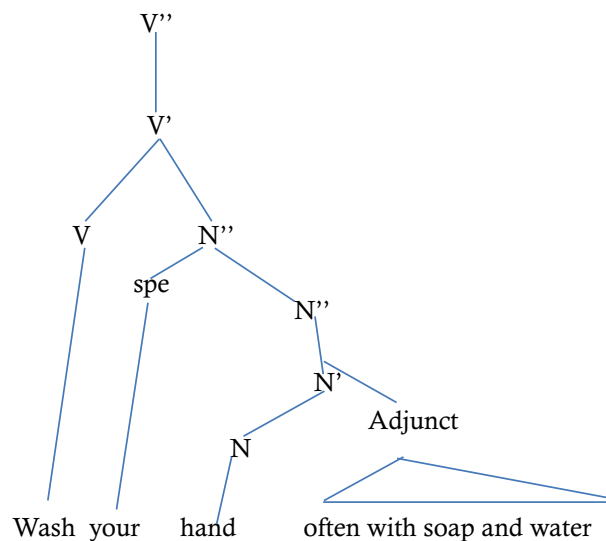

The above phrase structure tree displays the syntactic structure of the imperative sentence *wash your hand often with soap and water*. The subject of this verb phrase can be understood from the context as members of the general public. The subject can be understood as *you*, a second person pronoun, which can be singular or plural. The verb phrase (V'') consists of a single verb *wash* which serves as the head and projects an N'' as its complement. The projected N'' consists of a determiner *your* and a noun *hand*. This imperative sentence consists of an adjunct *often with soap and water*. This additional information is an instruction on how the people should wash their hands. The illocutionary acts conveyed are advise, directive or even command.

The target audience are expected to comply.

### **Conclusion**

This study has analysed the syntactic structures and communicative acts in online Covid-19 communication campaign posters. The data analysed revealed that Covid-19 communication campaign messages are designed to persuade certain the general public in order to influence their behaviour and attitudes. Imperative and declarative sentence were found predominately. These agree with the fact that both sentences used to be simple and convey clear and explicit information. The imperatives are mostly agentless, but the subjects can easily be inferred from the context of the covid-19 campaigns as the general public

The analysis of the syntactic structure of the verb phrases functioning as imperative sentences revealed that they contain noun phrases as their complements. These noun phrases complete the meanings of the verbs. Verbs of action were prevalently found as the heads of the verb phrase. This further justifies the assertion that covid-19 messages are designed to educate and persuade the audience to take all preventive measures. The verbs such as practice, stay, avoid, wash, stop, wear among others inform the audience to perform preventive actions. The analysis of the declarative sentences showed that contain noun phrase in the subject and a verb followed by complements. Just like the imperatives, the declarative sentences contain verbs of action. The analysis of the communication acts revealed that locutionary acts are clear, straightforward and meaningful. The illocutionary acts they convey include directive, request, instruction, command or advice. These are acts committing the general public perform preventive actions.

### **References**

- Cennimo, D. J. & Bergman, J. (2020). Coronavirus disease 2019 (Covid-19): Essential practice, medscape: <https://login.medscape.com>
- Cook, V. & Nelson, M. (2007). *Chomsky's universal grammar*, Blackwell publishing.
- Chopra, A (2021). How the pandemic has impacted and added to the English language. [ETBrandEquity.com](https://ETBrandEquity.com) May 17, 2021, 09:02 IST
- Finegan, E. (2009). *Language: its structure and use, fifth edition*, International Student Edition Thomson Wadsworth, United State.
- Fromkin, R. & Hyams, N. (2003). *An introduction to language, seventh Edition* Thomson Wadsworth, United State.
- Goyal, C. (2021). Part II: step by step guide to masters NLP-Syntactic Analysis.

- Guo, Y. R., Cao, D. Q., Hong, S. Z., Tan, Y. Y., Chen, D. S., Jin, J. H., Tan, S. K., Wang, Y. D. & Yan, Y (2020) The origin, transmission and clinical therapies on coronavirus disease 2019(Covid-19) outbreak-an update on the status. *Military Medical Research*, March, 2020.
- Haegeman, T. (1993). *Introduction to government and binding theory*, Blackwell, Oxford, UK & Cambridge, USA
- Khan, M., Adil, S. F., Alkhatlan, H. Z., Tahir, M. N., Saif, S., Khan, M., Khan, S.T. (2021). COVID-19: A global challenge with old history, *Epidemiology and Progress So Far*, *Molecules* 2021, 26, 39. [https:// dx.doi.org/10.3390/molecules26010039](https://dx.doi.org/10.3390/molecules26010039)
- Khotimah, K., Laksono, K., Suhartono, S., Pairin, U., Dari, D. ( 2021). Lingual expressions in the Covid-19-Related Ecolexicons in Indonesian online media coverage, *Journal of Language and Linguistic Studies*, 17(1), 309-326; 202
- MacKenzie, E. (2022). Guide to Health communication. [https:// www.mastersincommunications.com/features/guide-to-health-](https://www.mastersincommunications.com/features/guide-to-health-)
- Reddy, B.V. & Gupta, A. (2020). Importance of effective communication during Covid-19 infodemic, *J Family Med Prim Care*. 9(8), 3793–3796. Published online 2020 Aug 25. doi: [10.4103/jfmprc.jfmprc\\_719\\_20](https://doi.org/10.4103/jfmprc.jfmprc_719_20)
- Rural Health Information Hub (2022). *Health communication*, <https://www.ruralhealthinfo.org>
- Steve, C. (2020). *Covid-19: a brief history and treatments in development*, Wiley Clinical Health Care Hub. [https://doi.org.10.1002/psb.1843](https://doi.org/10.1002/psb.1843).
- Umakanthan, S., Sahu, P., Rande, A. V, Bukelo, M. M, Rao, J. S, Machando, L. F. A, Kumar, H., & Dhanajaya, K. V. (2020). Origin, transmission, diagnosis and management of coronavirus disease 2019 (COVID-19), *Postgraduate Medical Journal*, 96(1142) <https://bmj.com/coronavirus/usage>. <http://dx.doi.org/10.1136/postgradmedj-2020-138234>
- Yule, G. (2006). *The study of language, second edition* Cambridge, Cambridge University Press.



## PREVALENCE OF PEPTIC ULCER AMONG YOUTHS IN WUKARI, TARABA STATE, NIGERIA

<sup>1</sup>Imo Chinedu, <sup>2</sup>Asuelimen Steve Osagie, <sup>3</sup>Ale Ebenezer Morayo,

<sup>4</sup>Abah Moses Adondua <sup>5</sup>Gambo Asabe Mary & <sup>6</sup>Ikwebe Joseph

<sup>1,2,3,4&6</sup>Department of Biochemistry, Faculty of Pure and Applied Sciences,  
Federal University Wukari, Nigeria

<sup>5</sup>Wukari Study Centre, Faculty of Health Sciences, National Open University of Nigeria.

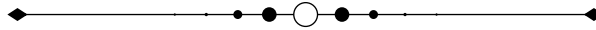

### **Abstract**

*This research study investigated prevalence of peptic ulcer among youths in Wukari, Taraba State, Nigeria. A peptic ulcer is a lesion that develops on the stomach or duodenal lining. Research questionnaires on the prevalence of peptic ulcer among youths in Wukari, Nigeria were distributed, collected and computed. The results showed that a good number of the respondents know about ulcers, while 41.7% has suffered an ulcer before. Only 13.9% of the youths are currently suffering ulcer. About 55.6% of the youths have undergone a laboratory test to detect ulcer, while 69.4% of the youths believe that ulcers are curable. Exactly 22.2% of the respondents knew someone who had died as a result of ulcer. About 27% of the youths have suffered peptic ulcer. About 9.6% of the youths are currently suffering peptic ulcer. Exactly 16.7% of the youths reported that starvation is the major factor that aggravates their ulcer. Also, majority of the youths considers starvation to be the major cause of ulcer in their communities. A good number of the youths reported that they know many people currently suffering ulcers. Exactly 44.4% prefer phytotherapy, while 55.6% prefer chemotherapy in the management of ulcers. Many youths in Wukari are very much aware of ulcers. Approximately 14% of the youths are reported to be suffering ulcer currently. Among those currently suffering ulcer now, 5.6% of the respondents are currently suffering stomach ulcer, while peptic ulcer was stated as the most prevalent ulcer which the residents in the respondent's community are suffering.*

**Keywords:** *Helicobacter pylori, Peptic ulcer, Prevalence, Starvation, Stomach, Youth.*

---

### **Background to the Study**

Peptic ulcer disease, which includes both stomach and duodenal ulcers, accounts for a significant portion of people seeking surgical advice around the world. A peptic ulcer is a lesion that develops on the stomach or duodenal lining. “Gastric ulcers” and “duodenal ulcers” are the two most prevalent peptic ulcer kinds (Jaiswal *et al.*, 2021). Peptic ulcers are caused by an imbalance between aggressive factors like hydrochloric acid (HCl), pepsin, refluxed bile, leukotrienes (LTs), reactive oxygen species (ROS), and defensive factors like the mucus-bicarbonate barrier, prostaglandins (PGs), mucosal blood flow, cell renewal and migration, nonenzymatic and enzymatic antioxidants. The most common causes of peptic ulcer disease are *H. pylori* infection and the use of nonsteroidal anti-inflammatory medications (NSAIDs). In addition, a variety of variables are implicated in the pathogenesis of gastric ulcer, including bacterial infection (*Helicobacter pylori*), certain drugs (NSAID), chemicals (HCl/ethanol), and stomach cancer, with minor factors including stress, smoking, spicy food, and nutritional deficiencies. The goal of treating ulcers is to reduce the quantity of acid produced by the stomach, neutralize the acid produced, and protect the wounded area so it can recover (Jaiswal *et al.*, 2021).

Peptic ulcer is a chronic disease that results from an imbalance between endogenous protective factors of gastric mucosa (mucus and bicarbonate secretion, adequate blood flow, prostaglandin E2, nitric oxide, sulfhydryl compounds and antioxidants enzymes, and others) and aggressive factors (acid and pepsin secretions). Behavioral and environmental factors such as smoking, poor diet, alcohol and non-steroidal anti-inflammatory drugs ingestion, and *Helicobacter pylori* infection, among others have also been implicated in the etiology of gastric ulcer (Lemos *et al.*, 2012). Peptic ulcer disease is often defined as a mucosal break greater than 3-5 mm in the stomach or duodenum with a visible depth. It is therefore an endoscopic diagnosis in contrast to dyspepsia, which is a clinical diagnosis based on symptoms alone. Peptic ulcer disease results from an imbalance between factors that protect the mucosa of the stomach and duodenum, and factors that cause damage to it patients with gastric and duodenal ulcers present similarly. They may report epigastric or retrosternal pain, early satiety, nausea, bloating, belching, or postprandial distress. These symptoms are non-specific and may be difficult to distinguish clinically from functional dyspepsia (Sverdén *et al.*, 2019).

Ulcers are an open sore of the skin or mucus membrane characterized by sloughing of inflamed dead tissue. Ulcers are lesions on the surface of the skin, or a mucous membrane characterized by a superficial loss of tissue. Ulcers are most common on the skin of the lower extremities and in the gastrointestinal tract, although they may be encountered at almost any site. There are many types of ulcers such as mouth ulcer, esophagus ulcer, peptic ulcer, and genital ulcer (Shoba, 2014). Ulcer is one of the most common diseases affecting throughout the world population. The allopathic treatment of ulcer adversely affects the health by causing harmful side effects. It impedes the organ of which that membrane is apart from continuing its normal functions. It is of many forms which occur on both, inside and outside of the human body. Currently, different types of ulcer forms are recognized in medicine such as peptic ulcer, corneal ulcer, stomach ulcer, foot or leg ulcer etc (Singh *et al.*, 2018).

The Gram-negative bacterium *Helicobacter pylori* remain present between the mucous layer and the gastric epithelium and are strategically designed to live within the aggressive environment of the stomach. Initially, *Helicobacter pylorus* reside in the antrum but over time

migrates toward the more proximal segments of the stomach. Peptic ulcer is one of the world's major gastrointestinal disorders and affecting 10% of the world population. About 19 out of 20 peptic ulcers are duodenal. An estimated 15000 deaths occur each year as a consequence of peptic ulcer. Annual incidence estimates of peptic ulcer hemorrhage and perforation were 19.4–57 and 3.8–14 per 100,000 individuals, respectively. The average 7-day recurrence of hemorrhage was 13.9% and the average long-term recurrence of perforation was 12.2% (Shoba, 2014). Ulcer index Scoring of ulcers was done as follows: No ulcer=0; Superficial ulcers= 1; Deep ulcers=2; Perforation=3. Mean ulcer score for each animal will be expressed as ulcer index. The percentage of ulcer protection was determined by formula: % Protection= [(Control mean ulcer index - Test mean ulcer index)/ Control mean ulcer index 100] (Umre *et al.*, 2018).

### **Materials and Methods**

#### **Study Duration and Location**

This current project research study was conducted for a period of three months from March, 2022 to June, 2022 in Wukari, Taraba State, Nigeria.

#### **Study Population and Design**

For the purpose of this study, I distributed the research questionnaire to many youths and received responses from one hundred and eight (108) youths in Wukari.

#### **The Inclusion Criteria**

The following criteria were included in the study:

- i. Youths, which includes male and female residing in Wukari, Taraba State, Nigeria.
- ii. Age  $\geq$  16 years.
- iii. Agree to fill the questionnaire.

#### **The Exclusion Criteria**

The following criteria were excluded from the study:

- a. Individuals (males and females) in Wukari below the age of 16 years.
- b. People who refused to give consent.

#### **Data Collection and Data Collection Instrument**

The entire information/responses used were as collected using the questionnaire designed for this project research purpose. Before distribution of the questionnaire, it was tested for its readability and understanding to the public. All the respondents were asked to answer all questions.



## Results

The results are presented below:

Table 1: Number and percentage of responses received from one hundred and eight (108) youths on some questions on prevalence of peptic ulcer.

Question/information	Number of responses as Yes	Percentage (%) of responses as Yes	Number of responses as No	Percentage of responses as No
Do you know about ulcers? Yes / No.	105.0	97.2	3.0	2.8
Have you suffered any type of ulcer before? Yes / No .	45.0	41.7	63.0	58.3
Are you currently suffering /experiencing any type of ulcer? Yes / No.	15.0	13.9	93.0	86.1
Have you ever undergone any laboratory test to detect ulcer? Yes / No.	60.0	55.6	45.0	41.7
Are ulcers curable? Yes / No.	75.0	69.4	3.0	2.8
Do you anybody who died majorly as a result of ulcer? Yes / No.	24.0	22.2	81.0	75.0

A very good number of the respondents know about ulcers, while 41.7% has suffered an ulcer before. Only 13.9% of the youths are currently suffering ulcer. About 55.6% of the youths have undergone a laboratory test to detect ulcer, while 69.4% of the youths believe that ulcers are curable. Exactly 22.2% of the respondents knew someone who had died as a result of ulcer.

Table 2: Percentage of some categorized responses received from one hundred and eight (108) youths on some questions on prevalence of peptic ulcer

Question/information	Percentage (%) of responses				
Which ulcer do you know mostly or have proper knowledge about?	Mouth: 2.0	Peptic: 50.0	Gastric: 11.0	Stomach: 8.3	---
Which type of ulcer have you suffered before?	Peptic: 13.9	Stomach: 11.1	Gastric: 2.0	---	---
If you have suffered ulcer before, what usually aggravates the ulcer you experienced?	Starvation: 16.7	Peppery food: 2.8	Fried food: 5.6	<i>H. pylori</i> : 5.6	---
Which type of ulcer are you currently suffering or experiencing?	Gastric: 2.0	Stomach: 5.6	Peptic: 2.0	---	---
How many people can you recall or know currently suffering any form of ulcer?	One to five: 22.2	Six to ten: 27.8	Many: 38.9	---	---
Do you prefer phytotherapy or chemotherapy in the management of ulcers?	Phytotherapy: 44.4	Chemotherapy: 55.6	---	---	---
Which type of ulcer do you know mostly affect people in your residential area or community?	Mouth: 2.8	Gastric: 8.3	Stomach: 16.7	Peptic: 25.0	I don't know: 33.3

What do you consider to be the major cause of ulcer in your community?	Bacteria: 13.9	Starvation: 38.9	Peppery food: 2.8	---	---
What are the common signs/symptoms of the ulcers you know?	Excess heat in the body: 2.8	Stomach pain: 36.1	General body discomfort: 2.8	Heart burn/pain: 50.0	Vomiting: 2.8

A good majority of the respondents claimed to have proper knowledge of peptic ulcer, while about 27% of the youths have suffered peptic ulcer. But about 9.6% of the youths are currently suffering peptic ulcer. Exactly 16.7% of the youths reported that starvation is the major factor that aggravates their ulcer. Also, majority of the youths considers starvation to be the major cause of ulcer in their communities. A good number of the youths reported that they know many people currently suffering ulcers. Exactly 44.4% prefer phytotherapy, while 55.6% prefer chemotherapy in the management of ulcers.

### Discussion

The responses received from one hundred and eight (108) youths on some questions on prevalence of peptic ulcer were collected and computed. Exactly 97.2% of the respondents know about ulcers, but 41.7% of the respondent have suffered ulcer (table 1). This showed that many youths in Wukari are very much aware of ulcers. Also, a good number of the youths have suffered ulcer. It means that the rate at which the youths suffer ulcer is high. Approximately 14% of the youths are reported to be suffering ulcer currently. This means some of those who suffered ulcers previously were able to treat the ulcer, thereby reducing the number of people currently suffering this ill health condition. The percentage of those currently suffering ulcer among the respondents showed that a reasonable number of the youths in Wukari may be suffering some forms of ulcers. This calls for an extra measure by healthcare workers in educating the public about ulcers and its consequences. Also, healthcare workers are expected to educate patients and the entire public on proper ulcer treatment and management practices. Only 55.6% of the respondents reported that they ever undergone any laboratory test to detect ulcer. Exactly 41.7% of the respondents have never undergone any laboratory test to detect ulcer. It is then possible that some of these respondents may be suffering any form of ulceration without knowing.

A good number of the youths believed that ulcer is curable. Only 3% of the respondents believed that it is not curable. This percentage may not be significant, but it is worrisome that up to 27% of the respondents do not know if ulcers are curable or not (as they did not respond to the specific question in this regard). The calls for more attention on sensitizing the general public on the ulcers, its diagnosis and treatment/management. This will help in curtailing the negative impact cause by ulcers. It is possible that ulcer may have caused the death of some people, since 22.2% of the respondents reported that they know someone who died majorly as a result of ulcer. this shows that ulcer is a serious public health concern condition from the responses of the respondents, those who have suffered ulcers suffered peptic ulcer. Most of the respondents are also more aware of peptic ulcer than other forms of ulcers. It has been reported that there are many types of ulcers such as mouth ulcer, esophagus ulcer, peptic ulcer, and genital ulcer (Shoba, 2014). Another research reported that different types of ulcer forms are recognized in medicine such as peptic ulcer, corneal ulcer, stomach ulcer, foot or leg ulcer etc (Singh *et al.*, 2018). Among those currently suffering ulcer now, 5.6% of the respondents are currently suffering stomach ulcer. The respondents also reported that they know a good

number of people currently suffering ulcer. this means that the prevalence of ulcer is currently on the high side. However, peptic ulcer was stated as the most prevalent ulcer which the residents in the respondent's community are suffering.

Among the causes of ulcers, the respondents reported starvation to be the factor that mostly aggravates the ulcers they have suffered. This is in agreement with a study which reported that pain in duodenal ulcers would be aggravated by hunger and relieved by a meal and is associated with night pain (Lanas and Chan, 2017). Starvation was also reported by 38.9% of the respondents (table 2) to be the major cause of ulcer in their communities. However, 13.9% reported bacteria (*H. pylori*) to be the major cause of ulcer in their communities. This means that the two major causes of ulcer among the respondents and their communities are starvation and *H. pylori*. This agreed with a previous report which stated that almost half of the world's population is colonized by *H. pylori*, which remains one of the most common causes of peptic ulcer disease (Siddique *et al.*, 2018).

Exactly 55.6% of the respondents prefer the use of chemotherapy in the treatment of ulcer, while phytotherapy was preferred by 44.4% of the respondents. This shows that more youths prefer the use of chemotherapy in the treatment or management of ulcer. The rate of eradication of ulcer was reported to have an increased tendency with the use of high-dose PPI and by extending the duration to 14 days (Dore *et al.*, 2016). However, it should be noted that there are reports of patients on PPIs developing vitamin B12 deficiency and iron deficiency anemia (Lam *et al.*, 2013). Also, PPIs might increase the risk for osteoporosis and bone fractures by interfering with the ionization and solubilization of the calcium salts which is required for their absorption (Koivisto *et al.*, 2005). Some of the common signs and symptoms of ulcer reported to be known by the respondents includes: excess heat in the body, stomach pain, general body discomfort, heart burn/heat and vomiting. This means that these signs and symptoms may be the ones commonly experienced by the youths.

### **Conclusion**

This study showed that many youths in Wukari are very much aware of ulcers. Also, a good number of the youths have suffered ulcer. Approximately 14% of the youths are reported to be suffering ulcer currently. The two major causes of ulcer among the respondents and their communities are starvation and *H. pylori*. From the responses of the respondents, those who have suffered ulcers suffered peptic ulcer. Most of the respondents are also more aware of peptic ulcer than other forms of ulcers. Among those currently suffering ulcer now, 5.6% of the respondents are currently suffering stomach ulcer, while peptic ulcer was stated as the most prevalent ulcer which the residents in the respondent's community are suffering.

### **References**

- Dore, M. P.; Lu, H. & Graham, D. Y. (2016). Role of bismuth in improving *Helicobacter pylori* eradication with triple therapy, *Gut*, 65 870–878.

- Jaiswal, F., Rai, A. K., Wal, P., Wal, A. & Singh, S. P. (2021). Peptic ulcer: A review on Etiology, Pathogenesis and Treatment, *Asian Journal of Pharmaceutical Education and Research*, 10(4), 1-17. doi.org/10.38164/AJPER/9.4.2021.01-17.
- Koivisto, T. T., Rautelin, H. I., Voutilainen, M. E., Heikkinen, M. T., Koskenpato, J. P. & Färkkilä, M. A. (2005). First-line eradication therapy for *Helicobacter pylori* in primary health care based on antibiotic resistance: Results of three eradication regimens, *Aliment. Pharmacol. Ther* 21, 773–782.
- Lam, J. R., Schneider, J. L., Zhao, W. & Corley, D. A. (2013). Proton pump inhibitor and histamine 2 receptor antagonist use and vitamin B12 deficiency, *JAMA*, 310, 2435–2442.
- Lanas, A. & Chan, F. K. (2017). Peptic ulcer disease, *Lancet*, 390(10094), 613–624.
- Lemos, L. M. S., Martins, T. & Tanajura, G. H. (2012). Evaluation of antiulcer activity of chromanone fraction from *Calophyllum brasiliense* Camb, *Journal of Ethnopharmacology*, 432–439.
- Shoba, F. G. (2014). A review on antiulcer activity of Few Indian medicinal plants, *International Journal of Microbiology*, 1-14.
- Siddique, O., Ovalle, A., Siddique, A. S. & Moss, S. F. (2018). *Helicobacter pylori* infection: An update for the internist in the age of increasing global antibiotic resistance. *Am. J. Med.*, 131 473–479.
- Singh, A. K., Singh, S. K. & Singh, P. P. (2018). Biotechnological aspects of plants metabolites in the treatment of ulcer: A new prospective, *Biotechnology Reports*, 2018; 2215-2217.
- Sverdén, E., Agréus, L. & Jason, M. (2019). Dunn gastroenterologist. *Practice*, 2, 1-8.
- Umre, R., Ganeshpurkar, A. & Ganeshpurkar, A. (2018). *In vitro*, *in vivo* and *in silico* antiulcer activity of ferulic acid, *Future Journal of Pharmaceutical Sciences*, 2314-7245.



## IMPACT OF CLIMATE CHANGE ON FOOD SECURITY IN NIGERIA

<sup>1</sup>Ishaku, Rimamtanung Nyiputen <sup>2</sup>Abu Maji <sup>3</sup>Okoh Abo Sunday

<sup>4</sup>Uwaeke, George Uchechukwu & <sup>5</sup>Yakubu Maigaji Ibrahim

<sup>1,2,3&5</sup>Department of Economics, Federal University Wukari, Taraba Nigeria

<sup>4</sup>Department of Economics, Ebonyi State University Abakaliki

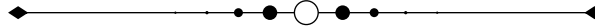

### **Abstract**

*Over the years, climate change and frequent herders-farmers conflicts had been the major causes of food security and its multiplier effects on economic growth in Nigeria. This paper aimed at examines the impact of climate change and herders-farmers clashed on food security in Nigeria. Time series data was used spading from 1999-2020, the characteristic of the data was examine with the help of Augmented Dickey Fuller (ADF) and Philips Perron unit root tests to determine the stationarity of the variables. Autoregressive Distributed lag model was adopted for the analysis. The results indicate that climate change exerted a negative effect on food security thus precipitating food insecurity during the period reviewed. Similarly, it was found that the scourge of insecurity among farmers and herders constituted a wedge in the quest for sustainable food production, giving rising to household's food insecurity. The study also found that government allocation to the agricultural sector was far below the recommended threshold. Given the preceding discovery, these results imply that Nigerian government should implement smart food systems or agricultural techniques that are resilient to the effects of climate change to ensure sustainable food production in Nigeria. The Government should evolve and implement policies protecting farmers against climate change and to curb herders-farmers crises. In particular, The Nigerian government should involve the mass media, community leaders and religious bodies on sensitization / campaigns to farmers and pastoralists on best practices so as to reduce the recurrent conflicts between pastoralists and farmers as well as ameliorate the tide of global warming. Furthermore, Government and the private sector should collaborate towards evolving global best practices in livestock management, such as grazing reserves and or ranching to reduce the conflicts associated with roaming or wandering of animals into people's farms.*

**Keywords:** Climate change, food security, Nigeria, sustainable food product

---



### **Background to the Study**

Climate change is the biggest environmental problem of our time that is threatening the existence of man and the environment. It is a major threat to agricultural system and food security in many countries in sub-Saharan Africa (Nigeria inclusive). Climate change or global warming refers to all changes in climate as a result of natural variations and human activities. Climate change has already been a widespread phenomenon. Climate change is a threat to food security as it has adverse effects on the agricultural system. Agricultural production in most Sub-Saharan African Countries (Nigeria inclusive) is dependent on weather. Climate change has a direct impact on the productivity of physical production factors such as soil's moisture and soil fertility and this affects farming outputs which in turn impacts negatively on food security. In other words, the food security of a nation depends on the stability and sustainability of sufficient food from the agricultural sector.

One of the requirements for achieving the sustainability of any economy wherever in the globe is food security. Given that food is without a doubt the most fundamental need for human survival, Brenner (2012). Basically, access to and availability of food constitutes food security. When a person does not experience hunger or the threat of starving, they are said to be food secure. The production and quality of the world's food resources have been greatly improved, but food insecurity still exists on a worldwide scale. Malnutrition brought on by food instability or shortages has led to a number of countries' inhabitants dying as a result. Behanassi, Dragon & Yaya (2011).

The world is currently facing climate change, an unavoidable environmental issue of the twenty-first century, and is looking for ways to adapt to it and lessen its effects. Human activity is directly or indirectly responsible for climate change, which modifies the global atmosphere over comparable time periods. The causes of climate change can be categorized into two groups, according to Okebukola and Akpan (2009) those that are caused by natural causes and those that are brought on by humans. The earth's tilt, comets, meteorites, ocean currents, and continental drift are among the main natural causes.

According to Agbo (2012), human activity is the primary cause of climate change. This is in accordance with Nzewi (2009), who earlier indicated that the current body of information will show that roughly 60% of the climate change is attributable to human activities such as altered land use, deforestation, agricultural and industrial operations, wars, and rising energy use. Others include using fertilizers, burning fossil fuels, dumping trash in landfills, driving a car, and using domesticated animals (Agbo, 2012). According to Scoones (2015), atmospheric greenhouse gases will have a significant influence on the net climate that results from the change. The negative effects of climate change have increased citizens' anxieties and worries that environmental degradation and population pressures may result in the eviction of millions of people across Africa and cause severe social unrest.

However, in recent times, major cities across the states of Nigeria have reported rising food prices, which have a negative influence on household budgets the consequences of climate change that cause concern in global livelihoods directly impact food security and as a result, there is a significant connection between food insecurity and other global challenges like population increase, rising energy demand, competition for land and water, and climate change. Despite the fact that some climate change-related issues are only just now starting to



surface, immediate action is required to give agricultural production systems adequate time to develop resilience. Uyinmwun B. Ighodaro (2019). Global concern over climate change has increased, endangering Nigeria's ability to expand its agricultural sustainably.

### **Literature Review**

The term climate change is also used synonymously with global warming which is defined by Oxford Dictionary of Science (2005) as an increase over time of the average air temperature on the earth. The dictionary further stated that throughout the geological history of the earth, there have been periodic fluctuations between warmer and cooler periods on a wide range of time scales. The causes of climate change are complex. Factors include the external processes of variations of solar emissions, variations of the earth's orbit, volcanic eruptions, mountain building and tectonic movements; anthropogenic (human-induced) processes. Thus, according to Okebukola and Akpan (2009), the causes of climate change can be divided into two categories – those that are due to natural causes and those that are created by humans. Prominent among the natural causes are continental drift, volcanoes, ocean currents, the earth's tilt, comets and meteorites.

Over the past 100 years, the earth's average surface temperature has risen by 0.75° Celsius. This rise in the temperature of the earth has brought some changes in the global weather pattern by affecting natural resources and balance of nature, upsetting seasonal cycles, disrupting the ecosystem and water supply, causing sea levels to rise, affecting agricultural productivity and food security. The Inter-governmental Panel on climate change defined climate change as statistically significant variations that persists for an extended period, typically decades or longer. It includes shifts in frequency and magnitude of sporadic weather events as well as the slow continuous rise in global mean surface temperature. United States Global Climate Change Programme defined climate change as Extreme reactions of the weather phenomenon which creates negative impact on agricultural resources, water resources, human health, depletion of ozone layer, vegetation and soil, leading to doubling of carbon dioxide concentration in the ecosystem.

The reality of the impact of climate change on agricultural development has been shown in a number of studies (Fischer et al., 2002; Spore, 2008). A substantial body of research has documented these wide-ranging effects on many facets of human societies (Wolfe et al., 2005; ODI, 2007; Apata et al., 2009) In Ethiopia, Gebreegziabher et al. (2011) examined the economic effect of climate change on agriculture productivity using a countrywide computable general equilibrium (CGE) model. The study observed that the impact of overall climate change will be relatively benign until approximately 2030, and thereafter worsen considerably. Further, the simulation results showed that, over a 50-year period, the projected reduction in agricultural productivity may lead to about 30% less average income, compared with the possible outcome in the absence of climate change. Using descriptive analysis, Ozor (2009) demonstrated the processes that lead to climate change so as to enable a better understanding of the concept.

Several studies have been conducted in Nigeria to determine farmers' vulnerability, perception and responses to climate change (e.g. Onuoha (2009); Umar (2008); Efe (2009); Ubachukwu (2005)) with appreciable results. Some other studies have equally been done to determine the effects of climate change on the production of some major food crops in some parts of the

country. For example, Efe (2009) studied the threat of climate change to food security and livelihoods in selected states in Nigeria, while Ubachukwu (2005) examined the effects of climate change on food productivity in the Niger delta. They find that climate change impacts significantly on all aspects of crop yields, availability of seeds, and access and utilization of foods. They noted that there were decreases in crop yields due to decreases in temperatures in the study areas and that most of the farmers had low level of awareness on the dangers of climate change. Efe (2008) highlighted the implications of climate change-induced variability's on food security and livelihoods and recommended that management issues raised by the study be translated into decision and policy making by stakeholders in order to ensure food security in northern Nigeria. Njoku (2006) discovered a downward trend in rainy days per annum in Sokoto and Kano, with Kaduna having only a slight reduction in its rain day per annum. This observed climate change induced variability was found to have a negative effect on annual crop yields. The study also found that a decrease in food crops availability occurred as rainfall and temperatures decreased in the study areas. Okoli (2008) finds that most of the environmental consequences of climate change manifest as physical changes such as sea level rises, higher local temperature and changes in rainfall pattern. Odjugo (2005) also studied the effects of climate change on the socio-economic development of Nigeria, and finds that climate change and existing climatic variability will have harsh effects on the low-income and marginalized poor people in Nigeria and will, in addition, make the process of eradicating poverty more difficult because of the negative effects of climate change on economic growth, poor people's livelihoods and assets and the level of risks to which the people are exposed to.

This present study, however, focuses on the effects of the variation in climate on the aggregate of agricultural output in Nigeria over a period of time (1999-2020). The objectives of this study are (1) to determine if there is any increase or otherwise in food security in Nigeria as a result of change in climate, (2) to examine the effect of farmers-herders conflicts on food security in Nigeria, (3) to evaluate the effect of agricultural output on food security in Nigeria.

**Methodology**

**Data**

The data used for this study were secondary data (time series) obtained from Central Bank statistical bulletin, the World Bank and World Governance Indicators database respectively. The data include climate change, security of farmers, government agricultural expenditure, agricultural output and food import.

The Augmented Dickey Fuller (ADF) unit root test would be conducted to determine their univariate time series behavior in the basic unit of observation. The essence of this test is to be sure that the variables used are stationary. The regression equation for the test is of the form:

$$\Delta X_t = a_1 + a_2 X_{t-1} + a_3 \Delta X_{t-1} + a_4 t + e_t \quad \dots\dots\dots (1)$$

Where;

- X = Time series
- t = A linear time trend
- Δ = the first difference operator
- a<sub>1</sub> = Constant
- e = the random error term.

The test on the coefficient of  $X_{t-1}$  in the OLS openness model is the test for the ADF unit root. The null hypothesis of the existence of a unit root is given as:  $H_0: X_{t-1}$  (1) The Mackinnon critical values give the critical values for the determination of the order of integration. The values of the Mackinnon and the ADF test statistics are compared and decision either to accept or reject the null hypothesis are taken.

**Model Specification**

This research model is proposed to be built based on the assumptions of Sen's theory of Poverty and Famine and deriving from Sen's proposition that the causes of food crisis and famine in many countries of the world did not occur as a consequence of just a gap in food supply but as a result of other socio-economic factors. The theoretical modelling for this study is thus specified as follows:

$$FdSec = \emptyset_0 + \lambda_1 CC + \lambda_2 INSEC + \lambda_3 GAX + \lambda_4 AGO + \lambda_5 FIMP + \mu_t \quad (2)$$

Considering that the unit root results have revealed mix-order of integration, the study adopts an Autoregressive Distributed Lags (ARDL) modelling in its estimation, consequently, the re-specified version of Eqn (2) will become

$$\begin{aligned} \Delta FdSec = & \alpha_0 + \lambda_1 CC_{t-1} + \lambda_2 INSEC_{t-1} + \lambda_3 GAX_{t-1} + \lambda_4 AGO_{t-1} + \lambda_5 FIMP_{t-1} + \\ & \sum_{j=1}^p \pi_1 \Delta CC_{t-j} + \sum_{j=1}^p \phi_1 \Delta INSEC_{t-1} + \sum_{j=1}^p \delta_1 \Delta GAX_{t-1} + \sum_{j=1}^p \theta_1 \Delta AGO_{t-1} + \\ & \sum_{j=1}^p \rho_1 \Delta FIMP_{t-1} + \mu_t \quad (\text{Eqn 2.1}) \end{aligned}$$

A general error-correction representation of the equations above is formulated as follows:

$$\begin{aligned} \Delta FdSec = & \alpha_0 + \sum_{j=1}^p \pi_1 \Delta CC_{t-j} + \sum_{j=1}^p \pi_2 \Delta INSEC_{t-j} + \sum_{j=1}^p \pi_3 \Delta GAX_{t-j} + \sum_{j=1}^p \pi_4 \Delta AGO_{t-j} \\ & + \sum_{j=1}^p \pi_5 \Delta FIMP_{t-j} + \delta_i ECM_{t-j} + \mu_t \quad (\text{Eqn ... 2.2}) \end{aligned}$$

Where:

- CC = Climate change
- INSEC = Security of farmers
- GAX = Government agricultural expenditure
- AGO = Agricultural output
- FIMP = Food imports
- $\mu_t$  = Stochastic error term / time trend

While  $\emptyset_0 + \lambda_1, \lambda_2, \lambda_3, \lambda_4, \lambda_5$  respectively are the parameter estimates

**Results and discussions**

**Descriptive Statistics**

The descriptive statistics properties of the variables are examined. This is to enable us unravel the nature of the distribution from which the data emanate. The Jaeque-Bera statistic was used to consider the normality, and this was fortified by the values of the skewness and kurtosis of the variables.

**Table 1: Climate Change and Food Security in Nigeria**

	FdSec	CC	Insec	Fimports	AGO	GAX
Mean	3.33E+13	99458.18	-1.8282	16.83704	85.54773	34.3701
Median	3.55E+13	96530.31	-1.9209	16.59229	86.12125	35.0148
Maximum	4.43E+13	133465.3	-0.0734	32.22869	103.5825	90.9327
Minimum	1.18E+13	73134.38	-2.2272	7.421751	66.35938	-1.783
Std. Dev.	9.57E+12	17216.04	0.35117	5.560083	11.85813	21.1087
Skewness	-0.69383	0.435781	2.53775	0.761364	-0.09666	0.39971
Kurtosis	2.502591	2.281759	11.4954	3.536977	1.827914	2.37003
Jarque-Bera	7.967773	4.676797	359.087	9.559166	5.174239	3.7984
Probability	0.018613	0.096482	0	0.008399	0.075236	0.14969
Sum	2.93E+15	8752320	-160.88	1481.66	7528.2	3024.57
Sum Sq. Dev.	7.97E+27	2.58E+10	10.7287	2689.564	12233.52	38765
Observations	88	88	88	88	88	88

**Source: Author's computation from E-views 10**

Table 1 presents the summary of descriptive statistics. The findings indicate that all the variables with the exception of agricultural expenditure and changing climatic conditions failed the Jarque-Bera (JB) test. The implication of this is that all the other variables (Food security, agricultural output, security of farmers, food imports and corruption) depart from normality. This is revealed by their low probability values of less than or equal to five percent. The skewness for the variables on the other hand is dominated by positive signs, showing that the distribution was skewed both to the right and to the left. This simply implies that even in a frequency distribution form, the data set analyzed was either dominated by positive values or was completely made up of positive values.

### *Stationarity Test*

The results from the ADF unit root tests are hereunder tabulated.

**Table 2: Augmented Dickey Fuller and Phillips-Perron Unit Root Test**

Variable		Level	1 <sup>st</sup> Difference	5% critical	
Order of		T-statistic value	t-statistic value	value	Integration
Log (FdSec)	ADF	-4.589590	****	-2.897223	I(0)
	P-P	****	-5.641896	-2.895512	I(1)
Log (AGO)	ADF	****	-2.071068	-1.944811	I(1)
	P-P	****	-6.418572	-2.895512	I(1)
Log (GAX)	ADF	****	-4.603415	-2.899619	I(1)
	P-P	-5.000352	****	-3.462292	I(0)
Log (CC)	ADF	****	-2.401597	-1.945024	I(1)
	P-P	****	-5.398142	-2.895512	I(1)

Insec/conflicts I(0)	ADF	-3.800537	****	-2.898623	
	P-P	-6.928200	****	-2.895109	I(0)
Log (Fimports)	ADF	****	-3.593024	-2/897223	I(1)
	P-P	****	-5.613984	-2.895512	I(1)

**Source: Author's computation from E views 10**

Table 2 above shows the results of unit root test using both Augmented Dickey-Fuller (ADF) and Phillips-Perron (P-P) at level and first difference. The unit root test indicates that the variables in the models are integrated of order zero I(O) or I(1) i.e. first difference stationary. A variable is assumed to be stationary (has no unit root problem), if the critical value in absolute term is less than the test statistic. After ascertaining the stationarity properties of the variables in the model, their long run relationship will be determined. However, with all the variables not integrated of the same order but having revealed a mix order of integration, that is, combination of I(O) and I(1) as shown above, the use of Johansen co-integration test has collapsed, thus the most appropriate choice now is the application of the popular Autoregressive Distributed Lags (ARDL) bound for co-integration to examine the existence of long run relationship amongst the variables in the model.

#### ARDL Bounds Testing for Cointegration

A cointegration test is one sure way of establishing the presence or absence of a long-run relationship among series in a model. Economically speaking, two or more variables will be cointegrated if they have a long-run or an equilibrium relationship between or among them (Gujarati, 2004:822). Given that all the variables are not integrated of the same order, but having revealed a mix order of integration, that is, combination of I(O) and I(1) as shown above, the use of Johansen co-integration test has collapsed, thus the the ARDL bounds testing method to cointegration (Pesaran & Shin, 1999; Pesaran, Shin, & Smith, 2001) was employed to check if there is cointegration or long-run relationship between the dependent and independent variables. The cointegration test results are reported in table 3.

**Table 3: ARDL Bounds Testing**

Test Statistic	Value	K
F-Statistic	5.347353	9

Critical Value Bounds		
Significance	I(0) Lower Bounds	I(1) Upper Bounds
1%	2.65	2.99
5%	2.14**	3.3
10%	1.88	2.99

Notes: The critical values are taken from Pesaran and Pesaran (1997: 478) with five regressors.

\*\* denote rejecting the null at 5% level of significance.

**Source:** Author's Computation Using E-views 10

From the ARDL Bounds Testing, the calculated F-statistics of the Wald Test reveals a figure of 14.91586, a value that is greater than the higher and lower bounds of the 95 percent critical value interval (2.14 – 3.3). This implies the rejection of the null hypothesis that no long-run relationship exists between the variables and thus concluding that there is evidence of a unique long-run cointegrating relationship between the series used in the model.

#### Estimation of the ARDL Longrun and Shortrun models:

Below is the longrun and short run regression output for climate change and food security in Nigeria.

**Table 4(A): Longrun Estimates**

Variable	Coefficient	Std Error	t-statistic	P-value
<b>Long-run Estimates</b>				
Dependent variable				
<b>(FdSec)</b>	1.835507	0.221643	8.281383	0.0000
CC	0.384526	0.078357	4.907352	0.0000
INSEC	0.015071	0.002853	5.282578	0.0000
AGO	0.045757	0.004940	9.263367	0.0000
GAX	-0.017762	0.004458	3.984615	0.0002
INSEC	0.015071	0.002853	5.282578	0.0000
CC	0.384526	0.078357	4.907352	0.0000
FIMPORTS	-0.002043	0.006367	0.320802	0.7498

**Source: Author's computation from E-views 10**

**Table 4(B): Short run Estimates for Model 1:**

Variable	Coefficient	Std Error	t-statistic	P-value
D(CC)	0.448313	0.119886	3.739497	0.0005
D(INSEC)	-0.001961	0.003878	-0.505696	0.6155
D(AGO)	-0.036213	0.012271	-2.951092	0.0050
D(GAX)	0.000732	0.003406	0.214998	0.8307
D(FIMPORTS)	-0.008420	0.007203	-1.168995	0.2484
<b>ECM(-1)</b>	<b>-0.670366</b>	<b>0.107583</b>	<b>-6.231131</b>	<b>0.0000</b>

**Source: Author's Computation Using E views 10**

The result of the estimated coefficients of the model showed that in the longrun, the coefficient values of all variables included in the climate change and food security equation were statistically significant in explaining the model. However, the shortrun estimates indicated that only agricultural output and climate change appeared statistically significant in relation to food security during the period reviewed. For instance, a unit increase in food production index (AGO), on average resulted to a proportionate increase in the aggregate food stock in Nigeria within the referenced period. However, in the short term, the reverse was the case as evidence from the short-run estimates revealed that low food production is the reason behind the prevailing food insecurity in Nigeria.

Again, evidence from the long-run and short-run estimates indicated that government spending on agriculture was statistically significant but exhibited negative influence on food security in Nigeria within the quarters studied. That is, every unit decline in food production



was a result of a fall or decline in government expenditure on the sector.

To confirm the above, the short-run coefficient value of insecurity was indicated to be negatively signed with the value -0.001961. Though it is not a strong predictor of food availability (food security) given its statistically insignificant value depicted by the t-statistics, however, the strength of joint significance as explained by the F-statistics, necessitate explaining the economic relationship, given the debilitating import of insecurity (conflicts, political violence, terrorism and banditry/kidnapping) on the Nigerian economy with particular reference to the food sector. In addition, 'the long-run and short-run coefficients estimates for food imports revealed that food imports had a negative and insignificant effect on food availability and households' welfare during the period examined.

### **Conclusion**

This study showed that climate change exerted a negative effect on food security thus precipitating food insecurity during the period reviewed. Similarly, it was found that the scourge of insecurity among farmers and herders constituted a wedge in the quest for sustainable food production, giving rising to households food insecurity. The study also found that government allocation to the agricultural sector was far below the recommended threshold. And given this understanding, a great majority of Nigerian households were food insecure. Similarly, food insecurity became endemic due to inadequate food imports to supplement local food production which was a consequence of unfavorable weather conditions as well as the unending conflicts between herders and farmers in Nigeria.

Given the preceding discovery, this study concludes that climate change and other associated vices accentuated household food insecurity from 1999 to 2020. And given these adverse outcomes, a pressing economic policy concern is to find ways to mitigate the negative consequences of food insecurity in Nigeria; thus the following are suggested for policy implementation:

- I. To stem the tide of rising sea levels across the major rivers in the country, the Nigerian government should prioritize the dredging of her rivers, particularly Rivers Niger and Benue to reduce the effect of overflow which often results to flooding that destroys food crops, particularly rice, during the rainy season.
- II. Smart food systems or agricultural techniques that are resilient to the effects of climate change should be adopted to ensure sustainable food production in Nigeria.
- III. The Nigerian government should involve the mass media, community leaders and religious bodies on sensitization/campaigns to farmers and pastoralists on best practices so as to reduce the recurrent conflicts between pastoralists and farmers as well as ameliorate the tide of global warming, which is already affecting food production in Nigeria.
- IV. Government and the private sector should collaborate towards evolving global best practices in livestock management, such as grazing reserves and or ranching to reduce the conflicts associated with roaming or wandering of animals into people's farms.

## References

- Adishi, E. & Oluka, N. L. (2018). Climate change, insecurity and conflict: issues and probable roadmap for achieving sustainable development goals in Nigeria, *International Journal of Social Sciences and Management Research*, 4(8), 12-20.
- Agbo, C. U. (2012). *Climate change and crop production in Nigeria: Effects and adaptation options*. In A. A. Enete & M.I. Uguru (Eds.). Critical issues in agricultural adaptation to climate change in Nigeria. 114-143. Enugu: Chenglo.
- Agwu, J. & Okhimamhe, A. (2009). *Climate change, Its impacts and adaptation: Gender perspective from the Northern and Eastern Nigerian*, Available from: [http://www.ng.boell.org/downloads/Gender\\_Climate\\_Change\\_in\\_Nigeria.pdf](http://www.ng.boell.org/downloads/Gender_Climate_Change_in_Nigeria.pdf). [Last accessed on 2017 Jan 03].
- Ayinde, A. S., Folorunsho, R. & Oluwaseun, A. E. (2020). Sea surface temperature trends and its relationship with precipitation in the Western and Central Equatorial Africa, *Climate Change*, 6(21), 36-51.
- Ayo, J. A., Omosebi, M. O. & Sulieman, A. (2014). Effect of climate change on food security in Nigeria, *Journal of Environmental Science, Computer Science and Engineering and Technology*, 3(4), 1763-1778
- Behanassi, D. & Yaya, H. (2011), [Effect of climate change on food security in Nigeria](https://www.researchgate.net/publication/322314491). Article in *Journal of Environmental Science, Computer Science and Engineering & Technology*, from <https://www.researchgate.net/publication/322314491>
- Brener, R. (2012), Impacts of climate change on fisheries and aquaculture: synthesis of current knowledge, adaptation and mitigation options. FAO Fisheries and Aquaculture Technical Paper No. 627. Rome, FAO, 628
- Efe, S. I. (2009). Climate change and food security in African: Delta state Nigeria experience. In: Anyadike, R.N.C., Madu, L.A., Ajaero, C.K., editors. Conference Proceeding on Climate Change and the Nigerian Environment, Nsukka, 29, 105-126
- Gebreegziabher, Z., Stage, J., Mekonnen, A., Alemu, A. (2011). *Climate change and the Ethiopian Economy: A computable general equilibrium analysis*, Environment for Development,
- Discussion Paper Series, EfD DP 11-09. German advisory council on global change (WBGU). (2003). *Climate protection strategies for the 21st Century: Kyoto and beyond*, Special Report. Berlin, Germany: WBGU. p1.
- Njoku, J. D. (2006). *Analysis of the effect of global warming on forests of Southeastern Nigeria using remotely-sensed data*, Unpublished PhD Dissertation, Department of Geography and Environmental Management. Owerri: Imo State University.

- Nwafor, J. C. (2007). *Global climate change: The driver of multiple causes of food insecurity in Sub Saharan Africa*, Paper Presented at the International Conference on Climate Change and Economic Sustainability. Awka: Nnamdi Azikiwe University, 12-14 June, 2007.
- Nzewi, U. (2009). Climate change and the biosphere. In U. Nzewi & B. Uzoechi (Eds.). *Strategies for environmental education: Focus on recent developments in climate change*, *Environment Education Series No. 13*, 37-54. Ibadan: STAN.
- Ogbo, A. I. & Onyedinma, A. C. (2012). Climate change adaptation in Nigeria: Problems and prospects, *Sacha Journal of Environmental Studies* 2(1) 130 – 145.
- Okebukola, E. & Akpan, W. (2009). *Impact of climate change on cocoa production in Nigeria*, Proceedings of the Annual National Conference of the Nigerian Association of Agricultural Economists, Nigeria. February, 2009.
- Okorie, F. C. (2003). *Studies on drought in the Sub-Saharan Region of Nigeria using satellite remote sensing and precipitation data*, Unpublished Working paper. University of Lagos
- Oxford Dictionary of Science (2005). *Oxford paperback reference*, United States: Oxford university.
- Ozor, N. (2009). *Understanding climate change: Implications for Nigerian agricultural policy and extension*, Paper Presented at the National Conference on Climate Change and the Nigerian Environment. Organized by the Department of Geography, Nsukka: University of Nigeria.
- Scoones (2015). *Hazards and opportunities: Farming livelihoods in dry land Africa*, Lessons From Zimbabwe. London, Zed Books.
- Ubachukwu, N. N. (2005). *Climate and Agriculture in Northwestern Nigeria*, Unpublished B.Sc. Project. Nsukka: University of Nigeria.
- Ughaelu, C. M. (2017). Contemporary environmental issues respect to food production in Nigeria, *Journal of Environmental Management*, 41(2), 108-117.
- Umar, A.T. (2008). *Global warming and the millennium development goals (MDGS) in Nigeria: A way forward*, Paper Delivered at the 5th Annual Conference of the Association of Nigerian Geographers (ANG) at the University of Calabar, 25th-28th August. p47-55.
- United Nations Development Programme [UNDP] (2018), Human development index (HDI), viewed 10 April 2017, from <http://hdr.undp.org/en/human-development-index-hdi>
- Uwazie, U. I. (2020). Consumption of different forms of fish in Abakaliki metropolis of Ebonyi State, Nigeria, *African Journal of Food, Agriculture, Nutrition and Development*, 20(2).

- World Bank (2016). North East Nigeria recovery and peacebuilding assessment: *Component by report*, World Bank, Abuja.
- Wossen, T., Berger, T., Haile, M. G. & Troost, C. (2018). Impacts of climate variability and food price volatility on household income and food security of farm households in east and west Africa, *Agricultural Systems*, 163, 7-15.
- Zwedie, A. (2014). Impact of climate change on food security: A literature review in Sub-Saharan Africa, *Journal of Earth Science and Climate Change*, 5(8), 225.



## AWARENESS OF HYPERTENSION AND HYPOTENSION AMONG YOUTHS IN WUKARI METROPOLIS, NIGERIA

<sup>1</sup>Imo Chinedu, <sup>2</sup>Abah Moses Adondua, <sup>3</sup>Asuelimen Steve Osagie, <sup>4</sup>Ale Ebenezer Morayo  
<sup>5</sup>Mohammed Maryam & <sup>6</sup>Ikwebe Joseph  
<sup>1,2,3,4&6</sup>Department of Biochemistry, Faculty of Pure and Applied Sciences,  
Federal University Wukari, Nigeria  
<sup>5</sup>Wukari Study Centre, Faculty of Health Sciences, National Open University of Nigeria.

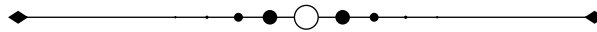

### **Abstract**

*This research study investigated the awareness of hypertension and hypotension among youths in Wukari, Nigeria. Hypertension (high blood pressure) is a long-term medical condition in which the blood pressure in the arteries is persistently elevated. Hypotension (low blood pressure) occurs when the blood pressure drops below the normal range. Research questionnaire was distributed to one hundred and twenty (120) youths in Wukari for the purpose of this research study. Their responses were collected and computed. The responses received showed that a good number of the youths have heard about hypertension and hypotension, but only 5% of the respondents have suffered hypertension and hypotension. Exactly 72.5% and 35% of the respondents reported to know someone who had suffered hypertension and hypotension respectively. People suffer hypertension more than hypotension. A good number of people may not be aware of hypotension. A greater percentage of the youths know what hypertension more than hypotension is. Only 25% of the youths know the normal human blood pressure. A good number of the respondents know common treatments of hypertension than hypotension. People are more aware of hypertension than hypotension. Most of the youths are aware of hypertension. The 5% who suffered hypertension and hypotension showed that hypertension and hypotension are not only suffered by the aged but may exist among youths. Only a few youths actually know the normal blood pressure. A comparison of the two ill health conditions showed that the youths are more aware of hypertension than hypotension.*

**Keywords:** Blood pressure, Cardiovascular disease, Hypertension, Hypotension, Public health.

### **Background to the Study**

Blood pressure (BP) is the pressure of circulating blood against the walls of blood vessels. Most of this pressure results from the heart pumping blood through the circulatory system. When used without qualification, the term "blood pressure" refers to the pressure in the large arteries. Blood pressure is usually expressed in terms of the systolic pressure (maximum pressure during one heartbeat) over diastolic pressure (minimum pressure between two heartbeats) in the cardiac cycle. It is measured in millimeters of mercury (mmHg) above the surrounding atmospheric pressure. Blood pressure is one of the vital signs—together with respiratory rate, heart rate, oxygen saturation, and body temperature—that healthcare professionals use in evaluating a patient's health. Normal resting blood pressure, in an adult is approximately 120 millimetres of mercury (16 kPa) systolic over 80 millimetres of mercury (11 kPa) diastolic, denoted as "120/80 mmHg". Globally, the average blood pressure, age standardized, has remained about the same since 1975 to the present, at approx. 127/79 mmHg in men and 122/77 mmHg in women, although these average data mask significantly diverging regional trends (NCD-RisC, 2017)

Traditionally, a health-care worker measured blood pressure non-invasively by auscultation (listening) through a stethoscope for sounds in one arm's artery as the artery is squeezed, closer to the heart, by an aneroid gauge or a mercury-tube sphygmomanometer (Booth, 1977). Auscultation is still generally considered to be the gold standard of accuracy for non-invasive blood pressure readings in clinic (Grim and Grim, 2016). However, semi-automated methods have become common, largely due to concerns about potential mercury toxicity (O'Brien, 2001), although cost, ease of use and applicability to ambulatory blood pressure or home blood pressure measurements have also influenced this trend (Ogedegbe and Pickering, 2010). Early automated alternatives to mercury-tube sphygmomanometers were often seriously inaccurate, but modern devices validated to international standards achieve an average difference between two standardized reading methods of 5 mm Hg or less, and a standard deviation of less than 8 mm Hg (Ogedegbe and Pickering, 2010). Most of these semi-automated methods measure blood pressure using oscillometry (measurement by a pressure transducer in the cuff of the device of small oscillations of intra-cuff pressure accompanying heartbeat-induced changes in the volume of each pulse) (Alpert *et al.*, 2014).

Blood pressure is influenced by cardiac output, systemic vascular resistance and arterial stiffness and varies depending on situation, emotional state, activity, and relative health/disease states. In the short term, blood pressure is regulated by baroreceptors, which act via the brain to influence the nervous and the endocrine systems. Blood pressure that is too low is called hypotension, pressure that is consistently too high is called hypertension, and normal pressure is called normotension (William, 2012). Both hypertension and hypotension have many causes and may be of sudden onset or of long duration. Long-term hypertension is a risk factor for many diseases, including stroke, heart disease, and kidney failure. Long-term hypertension is more common than long-term hypotension. Disorders of blood pressure control include high blood pressure, low blood pressure, and blood pressure that shows excessive or maladaptive fluctuation.

### **Materials and Methods**

#### **Study Duration and Location**

This current project research study was conducted for a period of three months from March, 2022 to June, 2022 in Wukari, Taraba State, Nigeria.



### Study Population

Research questionnaire was distributed to one hundred and twenty (120) youths in Wukari for the purpose of this research study.

### The Inclusion Criteria

The following criteria were included in the study:

- i. Youths, which includes male and female residing in Wukari, Taraba State, Nigeria.
- ii. Age  $\geq 16$  years.
- iii. Agree to fill the questionnaire.

### The Exclusion Criteria

The following criteria were excluded from the study:

- a. Individuals (males and females) in Wukari below the age of 16 years.
- b. People who refused to give consent.

### Data Collection and Data Collection Instrument

Responses used in this study were as collected using the questionnaire designed for this project research purpose. Before distribution of the questionnaire, it was tested for its readability and understanding to the public. All the respondents were asked to answer all questions.

### Results

The results are presented below:

Table 1: Number and percentage of responses received from one hundred and twenty (120) youths on some questions on awareness of hypertension and hypotension among youths in Wukari, Nigeria

Question/information	Number of responses as Yes	Percentage (%) of responses as Yes	Number of responses as No	Percentage of responses as No
Have you heard of hypertension before now? Yes / No.	111.0	92.5	3.0	2.5
Have you heard of hypotension before now? Yes / No.	87.0	72.5	30.0	25.0
Have you suffered hypertension before? Yes / No.	6.0	5.0	105.0	87.5
Have you suffered hypotension before? Yes / No.	6.0	5.0	96.0	80.0
Have you ever checked your blood pressure? Yes / No.	87.0	72.5	18.0	15.0
Do you know anybody that has suffered hypertension before? Yes / No.	87.0	72.5	27.0	22.5
Do you know anybody that has suffered hypotension before? Yes / No.	42.0	35.0	72.0	60.0
Is hypertension a regular health challenge in the community? Yes / No.	72.0	60.0	27.0	22.5

Is hypotension a regular health challenge in the community? Yes / No.	30.0	25.0	45.0	37.5
Do you believe many people are aware of issues of hypertension in your community? Yes / No.	81.0	67.5	27.0	22.5
Do you believe many people are aware of issues of hypotension in your community? Yes / No.	39.0	32.5	48.0	40.0

A good number of the youths have heard about hypertension and hypotension, but only 5% of the respondents have suffered hypertension and hypotension. Exactly 72.5% and 35% of the respondents reported to know someone who had suffered hypertension and hypotension respectively. People suffer hypertension more than hypotension. A good number of people may not be aware of hypotension.

**Table 2:** Percentage of some categorized responses received from one hundred and twenty

Question/information	Percentage (%) of responses				
What is hypertension?	Correct answer: 75.0	Wrong answer: 12.5	---	---	---
What is hypotension?	Correct answer: 52.5	Wrong answer: 15.0	---	---	---
When was the last time you checked your blood pressure?	Within the last 3 months: 17.5	Within the last 4 to 6 months: 7.5	Within the last 7 months to 1 year: 25.0	More than 1 year: 17.5	I can't remember: 10.0
What is the normal human blood pressure?	Correct answer: 25.0	Wrong answer/ I don't know: 55.0	---	---	---
Do you know any common treatment for hypertension?	Yes: 40.0	I don't know: 42.5	---	---	---
Do you know any common treatment for hypotension?	Yes: 7.5	I don't know: 67.5	---	---	---
Between hypertension and hypotension, which one do you think people around you are more aware of?	Hypertension: 92.5	Hypotension: 0.0	---	---	---

A greater percentage of the youths know what hypertension more than hypotension is. Only 25% of the youths know the normal human blood pressure. A good number of the respondents know common treatments of hypertension than hypotension. People are more aware of hypertension than hypotension.

### Discussion

Responses received from 120 youths in Wukari, Nigeria showed that 92.5% of the respondents have heard about hypertension before the distribution of the research questionnaire used in this study, but only 5% of the respondents have suffered hypertension. This result shows that most of the youths are aware of hypertension. The 5% who suffered hypertension showed that hypertension is not only suffered by the aged but may exist among youths. These youths may have therefore experienced the signs and symptoms of

hypertension which is not good for health. It has been reported that long-term high blood pressure is a major risk factor for some conditions such as stroke, coronary artery disease, heart failure, atrial fibrillation, peripheral arterial disease, vision loss, chronic kidney disease, and dementia (Lackland and Weber, 2015; Hernandorena *et al.*, 2017). A good number of the respondents (72.5%) also stated that they know people who have suffered hypertension. Exactly 60% of the youths declared that hypertension is a regular health challenge in their communities. This predicts hypertension to be a common ill health suffered by many in the communities of these respondents. It has been reported in research that for most adults, high blood pressure is present if the resting blood pressure is persistently at or above 130/80 or 140/90 mmHg (Poulter *et al.*, 2015), while different numbers apply to children (James *et al.*, 2014).

The responses received also showed that only 72.5% of the respondents have heard about hypotension before the distribution of the research questionnaire, but only 5% of the respondents have suffered hypotension. A comparison of the two conditions showed that the youths are more aware of hypertension than hypotension. This calls for more awareness of hypotension among youths in the community. This will help youth in avoiding dangers associated with hypotension. Low blood pressure will not deliver enough blood to the organs of the body. The organs may be damaged temporarily or permanently (Fedorowski and Melander, 2013) as a result of low blood pressure. Exactly 35% of the respondents (table 1) also stated that they know people who have suffered hypotension, while 30% of the youths declared that hypotension is a regular health challenge in their communities. This also predicts that beside hypertension, hypotension may also be an ill health condition that affects individuals in the communities of the respondents. A research stated that in 2010, hypertension was believed to have been a factor in 18% of all deaths (9.4 million globally) (Campbell *et al.*, 2015).

On the awareness of hypertension and hypotension in the communities of the respondents, 67.5% of the youths believed that many people are aware of issues of hypertension in their communities, while 32.5% of the youths believed that many people are aware of issues of hypotension in their communities. This also confirms that people tend to be more aware of hypertension than hypotension. Among the respondents, 15% have never checked their blood pressure. It is even possible that out of this 15% youth, some may have suffered either hypertension or hypotension without knowing. High blood pressure was reported to affect between 16 and 37% of the population globally (Poulter *et al.*, 2015).

Among the respondents, only 75% gave a correct answer to what hypertension is (table 2), while 12.5% of the youths gave a wrong answer to what hypertension is. Also, only 52.5% of the youths gave a correct answer to what hypotension is, while 15% of the youths gave a wrong answer to what hypotension is. This means that some of the respondents who reported to have heard of hypertension and hypotension do not actually know their true meaning. Also, only 25% of the respondents know the normal human blood pressure, while a higher percentage (55%) of the youths do not know the normal human blood pressure. These responses showed that only a few youths actually know the normal blood pressure. A research reported that in most adults, the normal blood pressure at rest is within the range of 100–130 millimeters mercury (mmHg) systolic and 60–80 mmHg diastolic (Mancia *et al.*, 2013).

More youths (40%) reported that they know common treatments for hypertension than the youths (7.5%) who reported to know common treatments for hypotension. However, majority of the youths do not know the common treatments for both hypertension and hypotension. This means there is urgent need for a continuous and comprehensive health education and sensitization on hypertension and hypotension to youths in various communities, especially, Wukari. Responses derived from the youths showed that only about 50% of them have checked their blood pressure between now and the last one year. There is need for the youths to improve in the duration they wait for before checking their blood pressure. This will help them detect earlier any onset of hypertension or hypotension. When the youths were asked: between hypertension and hypotension, which one do they think people around them are more aware of? Exactly 92.5% answered hypertension, while none of the youths responded yes to hypotension. This confirms that the youths and people around them are more aware of hypertension than hypotension.

### Conclusion

Most of the youths are aware of hypertension. The 5% who suffered hypertension and hypotension showed that hypertension and hypotension are not only suffered by the aged, but may exist among youths. Exactly 60% of the youths declared that hypertension is a regular health challenge in their communities. A comparison of the two conditions showed that the youths are more aware of hypertension than hypotension. This calls for more awareness of hypotension among youths in the community. Some of the respondents who reported to have heard of hypertension and hypotension do not actually know their true meaning. Only a few youths actually know the normal blood pressure.

### References

- Alpert, B. S., Quinn, D. & Gallick, D. (2014). Oscillometric blood pressure: A review for clinicians. *Journal of the American Society of Hypertension*, 8(12),930–938. DOI:10.1016/j.jash.2014.08.014.
- Booth, J. (1977). A short history of blood pressure measurement. *Proceedings of the Royal Society of Medicine*, 70(11), 793–799. DOI:10.1177/003591577707001112.
- Campbell, N. R., Lackland, D. T., Lisheng, L., Niebylski, M. L., Nilsson, P. M. & Zhang, X. H. (2015). Using the Global Burden of Disease study to assist development of nation-specific fact sheets to promote prevention and control of hypertension and reduction in dietary salt: A resource from the World Hypertension League, *Journal of Clinical Hypertension*, 17(3),165–167. DOI:10.1111/jch.12479.
- Fedorowski, A. & Melander, O. (2013). Syndromes of orthostatic intolerance: A hidden danger. *J Intern Med.*, 273(4),322-335.
- Grim, C. E. & Grim, C. M. (2016). Auscultatory BP: still the gold standard, *Journal of the American Society of Hypertension*, 10(3), 191–193. DOI:10.1016/j.jash.2016.01.004.

- Hernandorena, I., Duron, E., Vidal, J. S. & Hanon, O. (2017). Treatment options and considerations for hypertensive patients to prevent dementia, *Expert Opinion on Pharmacotherapy (Review)*. 18(10), 989–1000. DOI:10.1080/14656566.2017.1333599.
- James, P. A., Oparil, S., Carter, B. L., Cushman, W. C., Dennison-Himmelfarb, C., Handler, J., Lackland, D. T., LeFevre, M. L., MacKenzie, T. D., Ogedegbe, O., Smith, S. C., Svetkey, L. P.,
- Taler, S. J., Townsend, R. R., Wright, J. T., Narva, A. S. & Ortiz, E. (2014). Evidence-based guideline for the management of high blood pressure in adults: report from the panel members appointed to the Eighth Joint National Committee (JNC 8). *JAMA*, 311(5), 507–520. DOI:10.1001/jama.2013.284427.
- Lackland, D. T. & Weber, M. A. (2015). Global burden of cardiovascular disease and stroke: hypertension at the core, *The Canadian Journal of Cardiology*, 31(5), 569–571. DOI:10.1016/j.cjca.2015.01.009.
- Mancia, G., Fagard, R., Narkiewicz, K., Redon, J., Zanchetti, A. & Böhm, M. (2013). ESH/ESC guidelines for the management of arterial hypertension: the Task Force for the Management of Arterial Hypertension of the European Society of Hypertension (ESH) and of the European Society of Cardiology (ESC), *European Heart Journal*, 34(28), 2159–2219. DOI:10.1093/eurheartj/eh151.
- NCD Risk Factor Collaboration (NCD-RisC) (2017). Worldwide trends in blood pressure from 1975 to 2015: a pooled analysis of 1479 population-based measurement studies with 19·1 million participants, *The Lancet*, 389(10064), 37–55. DOI:10.1016/S0140-6736(16)31919-5.
- O'Brien, E. (2001). Blood pressure measurement is changing! *Heart*, 85(1), 3–5. DOI:10.1136/heart.85.1.3.
- Ogedegbe, G. & Pickering, T. (2010). Principles and techniques of blood pressure measurement. *Cardiology Clinics*, 28(4), 571–586. DOI:10.1016/j.ccl.2010.07.006.
- Poulter, N. R., Prabhakaran, D. & Caulfield, M. (2015). Hypertension. *Lancet*, 386(9995), 801–812. DOI:10.1016/s0140-6736(14)61468-9.
- William, A. N. (2012). *Dorland's illustrated medical dictionary (32nd ed.)*, Philadelphia, PA: Saunders/Elsevier.



## EFFECT ON STRENGTH OF CONCRETE MADE WITH PARTIAL REPLACEMENT OF SAND WITH MARBLE DUST

<sup>1</sup>Akinwunmi, Ayoola & <sup>2</sup>Isah, Jimoh Karikati  
Civil Engineering Technology Department  
Federal Polytechnic, Ile-Oluji, Ondo State, Nigeria

---

### **Abstract**

Concrete is a major component of most infrastructural facilities today because of its versatility. Concrete is a critical material in the construction industry. Sand is a major component in the production of concrete while marble dust is a by-product of marble that can be used completely or partially to replace sand in the production of concrete. Using marble dust as an alternative to sand in making concrete enhances its quality. Deteriorating environment caused by excessive exploitation of sand is a reason for exploring another material of similar quality that can replace sand in manufacture of concrete. This study was conducted in order to decide the effect on concrete strength made with part replacement of sand with marble dust. In this project, experiments were carried out to determine the compressive strength of concrete produced with marble dust instead of sand at varying percentages; the optimum replacement level was also determined. Additionally, sieve analysis tests were carried out on the sand and marble dust in order to determine their fineness modulus. All the concrete cubes were allowed to cure over 7-days, 14-days and 28-days separately. From the results obtained, concrete of maximum compressive strength was produced by replacing 50 percent of the sand with marble dust when compared with the other replacement levels. Compressive strength improved for the curing ages from using 100% sand up to 50% replacement of sand with marble dust. The maximum compressive strength obtained was 37 N/mm<sup>2</sup> after 28 days of curing and this occurred at 50% replacement level. The fineness modulus obtained for marble dust was 3.50 while that of the sand was 3.52. Marble dust can therefore be mixed with sand of similar fineness modulus as fine aggregate in concrete production.

**Keywords:** Construction industry, Compressive strength, Sieve analysis, Curing ages, Fineness modulus

---



### **Background to the Study**

Concrete is derived from the Latin word *Concretus*. *Concretus* means hardened or hard. Concrete is a major component in most infrastructural facilities today because of its versatility. Concrete is a material used in construction work and it is made up of cement, aggregates and water. The aggregates include fine aggregates (e.g. sand) and coarse aggregates (e.g. gravel). The hardening of concrete is known as curing. During the hardening process, a chemical reaction takes place between the cement and water to form solid crystals that join the aggregates together. In properly formed concrete, most of the volume is made up of fine and coarse aggregates, stable and grouped such that the fine elements totally seal the spaces between the coarse ones. Every particle is totally covered with a cement-water paste that joins it wholly to the surrounding particles. The greater part of concrete is made up of coarse and fine aggregates (Sandhu, 2019). The curing process does not stop suddenly unless it is manually disturbed. The curing proceeds steadily over long periods of time, but in practice, concrete is normally considered to be totally cured after 28 days (Gambhir). Aggregate materials help to make concrete mix more compacted and bound together by hydrated cement. This implies that the selection of aggregates should be given due attention as it not only affects the strength but the resilience of the structural performance of the concrete. Fine aggregate makes up 26% of the elements of concrete (Gamhir, 2018). Concrete is the most extensively used material in the construction industry in the contemporary age (Sohu, 2018). Aggregates (fine and coarse) make up 78% of the total 11.5 billion tons of concrete expended on a yearly basis (Singh, 2016). This huge amount of used aggregates has become an ecological issue, reducing natural resources at quicker rate than they are being renewed.

Marble is a stone extracted from ancient time as a result of the metamorphic conversion of carbonate stone, resulting in the formation of carbonate crystals. Marble has maintained its status over time because of its ornamental purposes (Celik, 2008). Marble was used in statues in antiquity; it is however mostly found nowadays in construction sites. Marble has the propensity to endure elements and exist for a long time without changing form. Marbles are used on stairways, floors, walls and highways; they also serve as colouring agents and fillers in paints. Marble dust is a by-product of marble rocks. About 25% of treated marble is converted into powder form (Soliman, 2013). There are various companies in Nigeria that deal in the supply of all kinds and sizes of marbles. Marble dust generated from marble industries in Nigeria is also increasing, thus creating a source of menace to the environment. Sand deposits mostly used as fine aggregates in concrete production, are decreasing on a daily basis. There is therefore a need to explore the use of other materials that can replace sand in the production of concrete. Several types of wastes from the marble industry can be used to replace sand (either completely or partially) in the production of concrete.

### **Justification of Research**

Generation of marble dust in Nigeria is increasingly becoming a threat to the environment, hence this research is an attempt to contribute to the sustainable development of the building industry where lots of construction wastes are continually being produced.

### **Aim and Objectives of the Research**

This work is aimed at determining how partial replacement of sand with marble dust will affect the strength of produced concrete. The objectives include:

1. Partially replace sand with marble dust as fine aggregate at 25%, 50% and 75% respectively.

2. Determine compressive strengths of the various concrete produced with different percentages of sand mixed with marble dust.
3. Determine grain sizes of sand and marble dust used in concrete productions.

### Literature Review

Fine aggregates are basically particles gotten from mining activities. Fine aggregates comprise of ordinary sand and other crushed particles of  $\frac{1}{4}$  inches in size or smaller. Examples of fine aggregates include sand, marble dust, fly ash, rice husk ash and sawdust.

**Sand:** Sand is a grainy substance made up of finely separated rock and mineral elements. Sand is composed of various materials but is identified by its particle size. Sand is derived from the destruction of rocks ranging in size from 0.003 inches to 0.2 inches. The particles of sand are bigger than silt but smaller than gravel. The various types of fine aggregates are natural sand, broken stone sand and broken gravel sand. Fine aggregates can be described as fine, medium or coarse sands, depending on their size (Gamhir, 2018).

**Marble Dust:** Marble stone is a kind of metamorphic rock formed from limestone conversion. Cutting and polishing of marble stone produces an unwanted product known as marble dust (Valeria, 2010).

**Fly Ash:** Fly ash is a by-product of burned ground coal in electrically powered plants. Fly ash comprises siliceous and aluminous compound that produces cement when water is present. Fly ash forms a material that is comparable to Portland cement when it is mixed with water containing lime. Fly ash is a key item in many construction materials, such as hollow blocks, mixed cement and mosaic tiles. Fly ash increases the strength and separation of concrete when it is used in concrete mixes, thus making it easier to pump (Reeta, 2021).

**Rice Husk Ash:** This is a by-product from the agro-industrial sector. Rice husk ash is potentially suitable for use as a complementary cementitious material because of its pozzolanic nature and high surface. The burning of rice husk produces rice husk ash. If the rice husk is burned in an open field, bad quality rice husk ash having high carbon content will be formed, a development which can also lead to air pollution. The resulting high carbon level will affect performance of produced concrete in an adverse way (Mo, 2019). Fineness modulus of fine aggregate is a number that denotes the average size of the particles. Fineness modulus are classified into four categories based on their particle sizes and these are namely coarse sand, medium sand, fine sand and extra fine sand (Sadanandam, 2016).

Naga (2019) presented the experimental enquiry on concrete by partially replacing sand with marble powder. That test result shows that using marble powder can improve the strength of the cured concrete. The compressive strength of the resulting concrete improved progressively with introduction of marble powder (from 10% to 50%) and cured for 7-days and 28-days separately. In a similar work presented by Ofuyatan (2019), the highest percentage increase in compressive strength was obtained when 25% of sand was substituted with marble dust.

**Sawdust:** Sawdust is a by-product of woodworking operations such as slicing, milling, grating and routing. It is composed of small chippings of wood. The woodwork operations can be performed by machines, portable power tools or hand tools (Wikipedia).

## **Materials and Methods**

### **Materials**

The materials that were used in the preparation of concrete samples are listed hereunder:

1. Portland cement was purchased at Ile-Oluji, Ondo State.
2. Sand and Gravel were obtained from a construction site within the campus of Federal Polytechnic, Ile-Oluji, Ondo State.
3. Marble dust was procured from a construction company at Oyo, Oyo State.

### **Methods**

The tests conducted at the Geotechnical Laboratory, Department of Civil Engineering Technology, Federal Polytechnic, Ile-Oluji, Ondo State are listed thus:

1. Sieve analysis test.
2. Compressive strength.

### **Sieve Analysis**

**Objective:** To determine the grain sizes of sand and marble dust

**Apparatus:** Sieve shaker, sample tray, weigh balance, stopwatch

#### **Procedure**

- (a) Collect samples from locations
- (b) Use sample tray to take samples to the laboratory;
- (c) Prepare the sieve shaker;
- (d) Weigh the empty sample tray;
- (e) Weigh the empty sieves;
- (f) Weigh the sand and marble dust respectively;
- (g) Pour 500g of sample materials to the shaker;
- (h) Set the stopwatch to five minutes on the shaker;
- (i) Measure the mass of each sieve and retained sample after five minutes.

#### **Precautions:**

- (1) Ensure the material is not forced through the sieve by hand pressure.
- (2) Ensure the samples and apparatus are handled with care

**Conclusion:** At the end of the tests, the percentage grain sizes of the samples (i.e. sand and marble dust) were determined.

### **Compressive strength**

**Objective:** To prepare concrete in cubes for curing in order to determine the strength of concrete

**Apparatus:** Weighing scale, Schmidt hammer, compacting rod, hand trowel, brush, spanner, head pan, curing tank, sieve, shovel, 150mm x 150mm x 150mm cube mould, lubricant, water

#### **Procedure:**

- (a) Loosen the bolt on the steel cube mould;
- (b) Clean the mould, apply lubricant and firmly tighten it back with a spanner;
- (c) Mix fine aggregate, coarse aggregate and cement with even distribution, then add water in batches till consistency is achieved;

- (d) Place the concrete in the cube mould for casting;
- (e) Split the mould into three equal parts;
- (f) Fill 1/3 of the cube mould with concrete, then compact 35 times using the compacting rod;
- (g) Fill 2/3 of the cube mould with concrete, then compact again 35 times using the compacting rod;
- (h) Fill the cube mould to overflow and compact 35 times using the compacting rod;
- (i) Level the topmost surface and even it out with a trowel (place cement mix and spread evenly on the entire area of the sample);
- (j) Indicate curing date on it and store in a cool dry to set for at least 24 hours;
- (k) De-mould the cube after 24 hours and keep specimen submerged in water for different time periods (7, 14 and 28 days respectively);
- (l) After the curing period, take away the specimens from the water and then wipe surplus water from their surfaces;
- (m) Weigh the specimens to determine their respective weights;
- (n) Clean the bearing surface of the Schmidt hammer;
- (o) Hold the Schmidt hammer firmly perpendicular to the cube surface and gradually push toward the cube surface until the hammer hits it;
- (p) Maintain the pressure on the hammer after impacting the cube surface;
- (q) The rebound number is read on the scale and recorded.

**Precautions:**

- (1) Ensure the Schmidt hammer is held perpendicular to the cube surface;
- (2) Ensure the readings on the hammer are recorded correctly.

**Conclusion:** At the end of the tests, the cubes were cured for the stipulated time periods of 7, 14 and 28 days respectively using different proportions of marble dust to sand as fine aggregate.

**Result and Discussion****Result**

Results of the two tests carried out are shown hereunder:

**Sieve Analysis****Table 1: Sieve Analysis Result for marble Dust**

Sieve No	Container Weight (g)	Container + Sample (g)	Mass retained <sup>1</sup> (g)	% retained <sup>2</sup>	Cumulative % retained	% passing <sup>3</sup>
10	114.2	114.4	0.2	0.04	0.04	99.96
5	114.2	130.7	16.5	3.3	3.34	96.66
2	114.2	137.5	23.3	4.66	8.00	92.00
1	114.2	155.3	50.1	10.02	18.02	81.98
0.5	114.2	222.6	108.4	21.68	39.70	60.30
0.25	114.2	332.3	218.1	43.62	83.32	16.68
0.105	114.2	189.9	75.7	15.14	98.46	1.54
0.75	114.2	118.4	4.2	0.84	99.30	0.70
Pan	114.2	117.7	3.5	0.7	100	0.00
Total			500	100		

**Table 2: Sieve analysis result for sand**

Sieve No	Container Weight (g)	Container + Sample (g)	Mass retained <sup>1</sup> (g)	% retained <sup>2</sup>	Cumulative % retained	% passing <sup>3</sup>
10	114.2	114.3	0.1	0.02	0.02	99.98
5	114.2	126.9	12.7	2.54	2.56	97.44
2	114.2	142.4	28.2	5.64	8.20	91.80
1	114.2	169.9	55.7	11.14	19.34	80.66
0.5	114.2	220.7	106.5	21.30	40.64	59.36
0.25	114.2	323.8	209.6	41.92	82.56	17.44
0.105	114.2	193.8	79.6	15.92	98.48	1.52
0.75	114.2	118.7	4.5	0.90	99.38	0.62
Pan	114.2	117.3	3.1	0.62	100	0.00
Total			500	100		

<sup>1</sup>Mass retained = (Container + Sample) – Container Weight

<sup>2</sup>% retained =  $\frac{\text{Mass retained}}{\text{Total mass retained}} * 100$

<sup>3</sup>% passing = 100 – (Cumulative % retained)

**Table 3: Cumulative percentage (%) of fine aggregate retained in sieve**

	Cumulative % of aggregate retained in sieve	
	Marble dust	Sand
	0.04	0.02
	3.34	2.56
	8.00	8.20
	18.02	19.34
	39.70	40.64
	83.32	82.56
	98.46	98.48
	99.30	99.38
Cumulative % retained	350.28	351.18
Fineness modulus <sup>4</sup>	3.50	3.51

<sup>4</sup>Fineness modulus = Cumulative % retained / 100

### Compressive Strength

**Table 4: Compressive strength for 100% sand and 0% marble dust**

Sample: Sand / Marble dust 100% / 0%							
Curing days	Mass (kg)	Volume (mm <sup>3</sup> )	Density (kg/mm <sup>3</sup> )	Area of cube (mm <sup>2</sup> )	Rebound	Compressive strength (N/mm <sup>3</sup> )	Avg. compressive strength (N/mm <sup>2</sup> )
7	7.40	3375000	2.19x10 <sup>-6</sup>	22500	26	24	26
	7.72	3375000	2.29x10 <sup>-6</sup>	22500	29	28	
14	7.08	3375000	2.10x10 <sup>-6</sup>	22500	29	28	30
	7.98	3375000	2.36x10 <sup>-6</sup>	22500	31	32	
28	7.82	3375000	2.31x10 <sup>-6</sup>	22500	31	32	33
	8.10	3375000	2.40x10 <sup>-6</sup>	22500	32	34	

**Table 5: Compressive strength for 75% sand and 25% marble dust**

Sample: Sand / Marble dust 75% / 25%							
Curing days	Mass (kg)	Volume (mm <sup>3</sup> )	Density (kg/mm <sup>3</sup> )	Area of cube (mm <sup>2</sup> )	Rebound	Compressive strength (N/mm <sup>3</sup> )	Avg. compressive strength (N/mm <sup>2</sup> )
7	8.16	3375000	2.42x10 <sup>-6</sup>	22500	27	26	28
	8.50	3375000	2.52x10 <sup>-6</sup>	22500	30	30	
14	8.26	3375000	2.45x10 <sup>-6</sup>	22500	31	32	31
	7.82	3375000	2.32x10 <sup>-6</sup>	22500	30	30	
28	8.34	3375000	2.47x10 <sup>-6</sup>	22500	32	34	35
	8.66	3375000	2.57x10 <sup>-6</sup>	22500	33	36	

**Table 6: Compressive strength for 50% sand and 50% marble dust**

Sample: Sand / Marble dust 50% / 50%							
Curing days	Mass (kg)	Volume (mm <sup>3</sup> )	Density (kg/mm <sup>3</sup> )	Area of cube (mm <sup>2</sup> )	Rebound	Compressive strength (N/mm <sup>3</sup> )	Avg. compressive strength (N/mm <sup>2</sup> )
7	7.94	3375000	2.35x10 <sup>-6</sup>	22500	27	28	29
	8.40	3375000	2.49x10 <sup>-6</sup>	22500	30	30	
14	8.14	3375000	2.41x10 <sup>-6</sup>	22500	33	36	33
	7.80	3375000	2.31x10 <sup>-6</sup>	22500	30	30	
28	8.74	3375000	2.59x10 <sup>-6</sup>	22500	31	32	37
	8.86	3375000	2.63x10 <sup>-6</sup>	22500	37	42	

**Table 7: Compressive Strength for 25% Sand and 75% Marble Dust**

Sample: Sand / Marble dust 25% / 75%							
Curing days	Mass (kg)	Volume (mm <sup>3</sup> )	Density (kg/mm <sup>3</sup> )	Area of cube (mm <sup>2</sup> )	Rebound	Compressive strength (N/mm <sup>3</sup> )	Avg. compressive strength (N/mm <sup>2</sup> )
7	6.88	3375000	2.04x10 <sup>-6</sup>	22500	27	26	27
	7.38	3375000	2.19x10 <sup>-6</sup>	22500	29	28	
14	7.72	3375000	2.29x10 <sup>-6</sup>	22500	29	36	32
	7.18	3375000	2.13x10 <sup>-6</sup>	22500	33	28	
28	7.16	3375000	2.12x10 <sup>-6</sup>	22500	30	30	34
	7.56	3375000	2.24x10 <sup>-6</sup>	22500	34	38	

**Table 8: Variations in Compressive Strength**

A	B	C	D	E	F	G	H
	0% marble dust	25% marble dust		50% marble dust		75% marble dust	
Curing days			Variation in strength (%) <sup>a</sup>		Variation in strength (%) <sup>b</sup>		Variation in strength (%) <sup>c</sup>
7	26	28	7.7	29	11.5	27	3.8
14	30	31	3.3	33	10	32	6.7
28	33	35	6.1	37	12.1	34	3.0

## Discussion

The sieve analysis was carried out to find out the grain size of the fine aggregates (i.e. marble dust and sand) used for the production of concrete. The grain size of the aggregate is expressed as fineness modulus. Please find hereunder the classification of fineness modulus.



**Table 9: Fineness Modulus classification**

S/No	Class	Fineness modulus range	Average particle size
1	Coarse sand size	3.1-3.7	$\geq 0.5\text{mm}$
2	Medium sand size	2.3-3.0	0.35-0.5mm
3	Fine sand size	1.6-2.2	0.25-0.35mm
4	Extra fine sand size	0.7-1.5	$< 0.25\text{mm}$

**Fineness modulus is a number representing the average size of the particles.**

From the test results, the fineness modulus for marble dust was 3.50 while that of the sand was 3.51. These figures show that both materials (i.e. marble dust and sand) used can be categorized as coarse sand (refer to Table 3.0 above).

The concrete cubes were cured in water for 7-days, 14-days and 28-days respectively. The compressive strength results showed variances in strength with diverse percentages of marble dust. It was also noticed that cubes cast with 25% and 50% marble dust had greater values of compressive strength than cubes cast with 75% marble dust. The use of marble dust improved the compressive strength of concrete by 7.7% for 7 days, 3.3% for 14 days and 6.1% for 28 days at 25% replacement of sand with marble dust. Using marble dust improved the compressive strength of concrete by 11.5% for 7 days, 10.0% for 14 days and 12.1% for 28 days at 50 percent replacement of sand with marble dust. The adding of marble dust improved the compressive strength of concrete by 3.8% for 7 days, 6.7% for 14 days and 3.0% for 28 days at 75% replacement of sand with marble dust. The highest percentage rise in compressive strength was obtained at 50% part replacement of sand with marble dust.

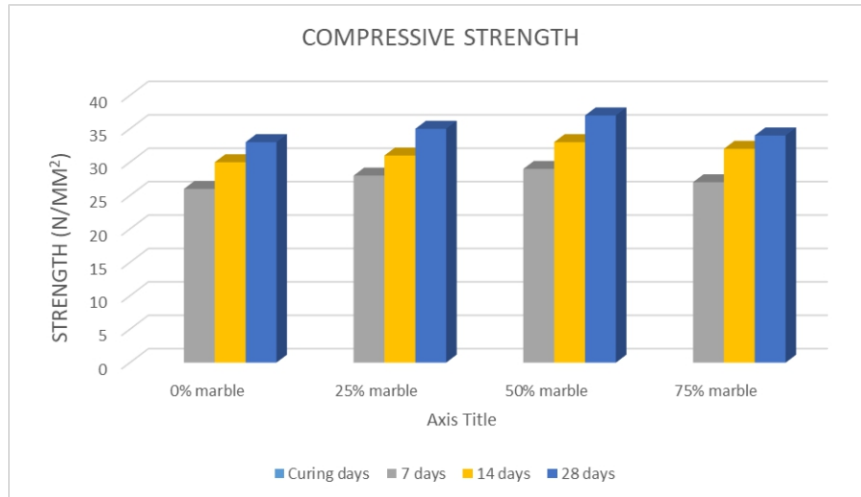

**Figure 1.0: Bar chart showing compressive strengths at different percentages of marble dust**

### Conclusion

Strength assessment of cement samples with varying amounts of marble dust show that concrete strength increases due to introduction of marble dust. Fifty percent measure of the marble dust as part replacement for sand is concluded as the peak amount from the results obtained. The compressive strength improved for all the curing ages from 0% to 50%

replacement of sand with marble dust. The maximum compressive strength that was obtained after curing for 28 days is 37 N/mm<sup>2</sup> and this occurred at 50% replacement level, resulting in 12.1% increase in compressive strength over concrete made with 100% sand as fine aggregate.

It can also be concluded from the sieve analysis test carried out on the marble dust and sand utilized for the concrete production that both materials used as fine aggregate fall under the same category of fineness modulus as they are categorized as coarse sand. The results obtained in this work are therefore applicable to the use of fine aggregates which can be classified as coarse sand.

### **Recommendation**

Following from this research work, the following recommendations are hereby made:

1. Sand can be used in combination with marble dust as fine aggregate in the production of concrete in equal ratio (i.e. 50% sand and 50% marble dust);
2. Sieve analysis test should be carried out on the sand and marble dust prior to using them in order to determine their individual fineness modulus.

### **Further Research Work**

There is a need to further research on this work by using a combination of marble dust and sand that belong to other classes of fineness modulus (i.e. medium sand, fine sand and extra fine sand respectively). This will help to ascertain if the fineness modulus of fine aggregate combination in concrete production has an impact on the compressive strength of concrete. A combination of different classes of fineness modulus for sand and marble dust mixture can also be explored. Tensile strength of the concrete may also be tested.

### **References**

- Celik, M. Y. & Sabah, E. (2008). Geological and technical characterization of Iscehisar (Afyon-Turkey) marble deposits and the impact of marble waste on environmental pollution, *Journal of Environmental Management* 87, 106-116
- Fadamiro, J. A., Ogunsemi, D. R. (2005). *Fundamentals of building: Design, construction and Materials*. Fancy Publications Limited, Ile-Ife, Nigeria
- Gambhir, M. L. & Jamwal, N. (2005). *Building and construction materials testing and quality Control*, Mcgraw
- Gambhir, M. L. & Jamwal, N. (2018). *Building materials: Products, properties and systems*, Tata McGraw Hill Education Private Limited, Nagar, New Delhi 110008.

<https://en.wikipedia.org/wiki/concrete> on Compressive Strength of Recycled Aggregate Concrete

Mo, K. H., Jhatial, A. A., Goh, W. I., Sohu, S., & Bhatti, I. A. (2019). Green and sustainable concrete-the potential utilization of rice husk ash and eggshells, *Civil Engineering Journal* 5(1), 76

Ofuyatan, O., Olowofoyeku, A. M., Obatoki, J., & Oluwafemi, J. O. (2019). Utilization of marble dust powder in concrete, *IOP Conference Series Materials Science and Engineering* DOI:10.1088/1757-899X/640/1/012053

Poon, C. S., Shui, Z. H., Lam, L., Fok, H., & Kou, S.C. (2004). Influence of moisture state of natural and recycled aggregates on the slump and compressive strength of concrete, *Cement and Concrete Research* 34(1), 31-36

Reeta, C. (2021). Fly ash an environmental issue and construction material, *Journal of Emerging Technologies and Innovative Research (JETIR)* 8(6) ISSN-2349-5162

Sadanandam, A. (2016). Fineness modulus of sand (Fine Aggregate)-calculation, values, <https://theconstructor.org/practical-guide/fineness-modulus-of-sand-calculation/12465/?amp=1>

Sandhu, A. R., Lakhari, M. T., Jhatial, A. A., Karira, H. & Jamali, Q. B. (2019). Effect of river Indus sand and recycled concrete aggregates as fine and coarse replacement on properties of concrete, *Engineering, Technology & Applied Science Research* 9(1), 3831-3834

Saran, T.N., & Das, T. V. (2019). Experimental investigation on concrete with partial replacement of fine aggregate by marble dust powder, *International Journal of Recent Technology and Engineering (IJRTE)* 7(6C2)

Singh, S., Tiwari, A., Nagar, R., Agrawal, V. (2016). Feasibility as a potential substitute for natural sand: A comparative study between granite cutting waste and marble slurry, *Procedia Environmental Sciences* 35, 571-582

Sohu, S., Ullah, K, Jhatial, A. A., Jaffar, M, Lakhari, M.T. (2018). Factors adversely affecting quality in highway projects of Pakistan, *International Journal of Advanced and Applied Sciences* 5(10), 62-66

Soliman, N. M. (2013). Effect of using marble powder in concrete mixes on the behavior and strength of R.C. slabs, *International Journal of Current Engineering and Technology* 3(5), 1863-1870

Valeria, C., Giacomo, M., & Tarun, N.V. (2010). Characterization of marble powder for its use in mortar and concrete, *Construction and Building Materials* 24, 113-117



## THE EFFECTIVENESS OF INVENTORY MANAGEMENT AND PROFITABILITY OF MANUFACTURING FIRMS

<sup>1</sup>George Charisma (PhD) & <sup>2</sup>Igho Enamejewan Gift

<sup>1&2</sup>Department of Accounting, School of Management Science,  
Federal Polytechnic Ekowe, Bayelsa state, Nigeria

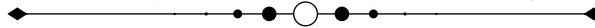

### Abstract

*This qualitative research study the effectiveness of inventory management and Profitability of Manufacturing Firms. The specific objectives were to review the effectiveness if inventory management and profitability in manufacturing firms and examine and review the extent at which effective inventory management methods lead to Profitability of manufacturing Firm., Base on the above findings, the following conclusion were made; effective inventory management oof finished goods leads to profitability manufacturing firms it therefore recommended that manufacturing company cannot regulate the importance of evolving, and maintaining effective inventory control system, there are needs for them to adopt a proactive attitude towards the issue. Being proactive requires maintenance of a right level of inventory at any point in time. Organizations should avoid the dangers that are inherent to little or too much of stock. Manufacturing company in Nigeria should develop a policy framework to facilitate faster implementation of best inventory management practices. Manufacturing companies should adopt the inventory keeping method that best suits their operations and also prevent stock-outs. There is also the need for organizations to train their personnel in the area of inventory control management. What this means is that only trained professionals with the required professional skill takes charge.*

**Keywords:** IFRS, Financial Reporting, Financial Institutions, Liquidity, Financial Statement

---

### **Background of the Study**

Inventions are vital to the successful and manufacturing and retailing organization. The need for inventory control cannot be overemphasized as it is a means for improving the performance of manufacturing industries. Inventory is one of the resources that are managed by the organization and its work first recorded in 1601. Inventory can be defined as record of a business current assets including property owned, merchandise on hand and the value of work in progress and work complete but not sold and it is classified as a current asset because it can be turned into liquid cash within a short period of time (Moore, Lee and Taylor, 2003:23). Inventory has created a great impact on the profitability on the manufacturing firm which led to the deep research of this topic. Inventory plays a major role in the operation of many business and manufacturing companies. In manufacturing, inventories of raw materials allow companies to operate independently of their source of suppliers. Day to day operation is not dependent on deliveries from suppliers since inventory of the necessary materials is maintained and used when needed. Without inventory control, millions of naira could be lost because of non-profitability of stocks and inaccurate checks and balances. According to Ohno (212) the process of control and management of inventories is an important factor in the success and failure of any business for example. Little inventory will result in inventory out which will disrupt the production distribution cycle that is crucial to the survival of the manufacturing companies, while too much stock will tie down the resources of a company. Poor or inadequate inventory can present a serious challenge to the productive capacity of the manufacturing organization. In addition to raw materials and finish goods, many companies also supply business firms and general operation supplies often constitutes of the most significant part of current assets companies.

In the public limited companies, inventories are approximately 60% of current sales assets on the average (Jonah, 2011). The US bureau of the census started inventory and accounts receivable are the two largest account of equal magnitude and together they comprise almost 80% of current assets over 30% of total assets for all manufacturing companies in 1982. Considering the large sum of money that is committed to the stocks of raw materials work in progress and finished goods, it is therefore paramount necessity. In inventory there is an optimum level therefore inadequate cause loss of sale and disrupts the production process while excessive stock levels lead to unnecessary carrying cost and obsolescence or spoilage risks. According to Charles T. Harrent (21), the optimum inventory level lies between the inadequate inventories and the excessive inventories. Inventory management aim at maintaining an optimum inventory level that will be carried at the least cost.

### **Objectives of the Study**

The specific objectives of the study are as follow:

- i. To review the effectiveness of inventory management and profitability in manufacturing firms
- ii. To examine and review the extent at which effective inventory management methods lead to Profitability of manufacturing Firms.

## **Review of Related Literatures**

### **Concept of Inventory**

There is need for installation of proper inventory control techniques in any business organization in developing countries, like Nigeria. According to Kotter (2005), inventory management refers to all the activities involved in developing and managing the inventory levels of raw materials, semi-finished material (work-in-progress) and finished goods so that adequate supplies are available and over or under stocks are low. Rosenblatt (1996) says “the cost of maintaining inventory is included in the final price paid by the buyer, good inventory represents a cost to their owner, and manufacturer has the expense of materials and labour. The wholesalers also have funds tied up” therefore the basic goal of researcher is to maintain a level of inventory that will provide optimum stock at lowest cost

Falope et al (2009) opened that inventory management in its broad perspective is to keep economical amount of one kind of asset in order to facilitate an increase in the value of all assets of the organization-human and materials resources. Ken et al (2002) in their text also state that the major objectives of inventory management and control is to inform manager how much of good to re-order, when to re-order the goods, how frequently orders should be placed and what appropriate safety inventory is for minimizing stock-outs. Thus, the overall goal is to have what is needed and to minimize the number of times one is out of inventory. Inventories are vital to the success of manufacturing and retailing organizations. This is because many companies hold inventories as part of current assets of most companies especially the manufacturing companies, the need for management to ensure inventory control if properly managed cannot be over emphasized.

A firm neglecting inventory management will be jeopardizing its long run profitability and it may end up failing in its business of inventories has been defined by many professional bodies scholars in different ways. The Microsoft Encarta premium defined it as the quantity of goods and materials on hand. A manufacturer's inventory represents those items that are ready and available for sale. According to Nwandu (2010), inventory can be defined as a tangible property held to resale in the ordinary course of business, in the production for sale, to be consumed in the production of goods and services. According to Moore et al (2003), inventory is the aggregate of these items of intangible property which are held for sale in the ordinary course of the business, held in the process of production for such sales to be currently consumed in the production for such sales to be currently consumed in the production of goods and services to be made available for sale. However, according to Amogu (2009), inventory is the stock of goods a firm is producing for sale and the components that make up the goods.

### **Types of Inventories**

Vishery (2011) classified inventories according to the purpose for which they are held, he stated that inventories may be held for a variety of purpose, but in general these are five types of inventories that an organization can be used for serving these purposes and they include



**Movement Inventories**

Is also called transit inventories it is due to the first that transportation time is involved in transferring substantial number of resources for example, when goods on transit they cannot provide any services to the consumer.

**Buffer Inventories**

This is also known as reserve stock, this is a stock of basic commodity accumulated by a government when supplies are plenty, and prices are low and for use when supplies are short to establish the price. Buffer inventories are so as to protect against the uncertainties of demand and supply. An organization generally knows the average and could well exceed it. To be able to handle this kind of situation, inventories may be held in excess expected demand.

**Anticipated Inventories**

These inventories are held for the purpose of the future demand for a product. This situation occurs when a company embarks on the production of some specialized before the season for them set in for example, the production of umbrella and rain coat before the raining season sets in.

**De-coupling Inventories**

This is to disengage different parts of the production system. Inventories in between the various machines are held in order to disengage the processing on these machines. Different machines and people formally work at different rates so that when a machine breaks down the work will not stop. The coupling inventories act as a cushioning effect in the face of the varying works rates and machine failure.

**Cycle Inventories**

These inventories are held for the purpose of purchases which are usually made in lots rather than for the exact amounts which may be needed at a point in time. If all purchases are made exactly as at when the item is required, these could be in cycle inventories.

**Classification of Inventories**

According to Lucy (2009) inventories are classified in manufacturing companies as follows:

**Raw Materials**

This is defined as an unprocessed nature product used in manufacturing processes. Hardly et al (2007:37) defined raw materials are directed materials inside inventory awaiting use in the manufacturing process. Finished goods of an ordinary industry might be the raw materials of another. Pandey (2010) defines raw materials as these basic inputs that are covered into finish products through the manufacturing process. This usually consists of the essential item needed to create or make a finished product.

**Work-In-Progress**

This can be defined as an incomplete ongoing piece of work; it also refers to items that are partially completed but yet finished products. It also refers to the inventory of all materials are

usually found between raw materials and finish good. Walter et al (1999/307) defined work-in-progress as partly finished goods and materials subassemblies between manufacturing stages

### **Finished Goods**

These are the products that are completed and that are ready to be purchase by consumers. Pandey (2019) defined goods as those products that are completed and ready for sale.

### **Inventory Policy**

This type of decision to be taken about inventory management is similar regardless of the size and complexity of the business. However, all decision may be made by one man in a simpler or smaller business, while a bigger or separate level of top management will usually be concerned with inventory decision in complete business.

Inventory policy is used as guides in the process of establishing programs and controls in business organizations so that a suitable rate return will be earned in the inventory investment. In most cases the decision or policies will recover:

- i. How much to order i.e. the optimal quantity of an item could be ordered whenever an order is placed
- ii. When should and order be placed?
- iii. How much safety stocks should be kept?

### **Reasons for Inventory**

These are many reasons why organizations maintain inventory of goods. Th3e fundamental reasons for doing so that it is either physically impossible or economically unsound to have goods manufactured whenever they are demanded for without inventory of goods, customers would have to wait until goods they ordered for are manufactured.

There are some other reasons for keeping inventory they are: the fluctuation nature of price of raw materials may make an organization stock up inventory to buy in large quantity and keep it in inventory so it can last through high price seasons.

According to organ (2013) the reasons for inventory are as follows

1. To give customers assurance of availability
2. To handle production variations
3. To provide customers service in the face of sales fluctuation and other problem
4. To await shipment to fill unexpected order.
5. To allow for batch production
6. To provide raw materials storage
7. To keep storage equipment operational
8. To protect against strike and work stop pages
9. To be ready when unforeseen circumstances occur.

According to Pandey (2002:1885) a company should maintain adequate stock of materials for an interrupted production for customer's supply

The following are reasons for inventory

- i. To take advantage of seasonal fluctuation in price and price will be minimized by having inventories of raw materials.
- ii. To take advantage of price discounts when order are placed in large quantities.
- iii. To allow firms to meet orders that is placed in spite of temporary unexpected fluctuation in the rate fo output.

### **Inventory Control**

Control in management is the activity of determining whether resources have been provided and production carried out in accordance with plan and where this is not the case, taking corrective measure are needed. Control is the process of instituting procedures and obtaining feedback as needed to ensure all parts of the organization are functioning effectively and moving towards the overall company goals.

Inventory control can be defined as an inventory policy designed to obtain right quantity and right quality of raw materials at the right places. It can also include the recording and monitoring of stock levels. Forecasting future demand and deciding when and how many to order. Nweze (2004:423), defined inventory control as the means for ensuring that actual flow of inventory in an organization confirm a plan. Ekeani (2010:25), defined inventory control as the technique used by store managers to ensure that materials are made available when they are needed in the quantity, quality and price that they are needed without the risk of inventory out and over stocking.

However, for inventory control to be effective there must be a plan which is the development of objectives in an organization and preparation of various budgets to achieve these objectives, planning of inventory is very essential in an organization. A firm should be able to determine its optimum level of investment in inventories. This situation can only be possible when the company ensures that stocks are sufficient to meet the requirements of production and sales, and the companies avoid holding surplus inventories that are necessary because it increases the risk of obsolescence. Against this, a company cannot afford loss of sales because of insufficient inventories and at the same time, is expensive to have more inventories on hand than necessary. Various departments within the same company adopt different views attitude towards inventories for instance, the sales department of a company might desire large inventory in reserve to meet virtually every demand that comes. The production department with in the same company would similarly ask for large inventories of materials so that the production system will not be interrupted. On the other hand, the finance department would always request for a minimum investment in inventories so that the fund can be used somewhere else for other purpose. Therefore, inventory control involves the recording and monitoring of stock levels, determining the optimal levels and forecasting future demands and decisions. The main aim to inventory control is minimize cost associated with stocks.

### **Inventory Level**

- i. **Re-order Level:** This is the level where an item in inventory reaches and these will be an order for replenishment. There will be a certain level which the items in stock will

fall and it will necessitate a new order to be placed. Some of the re-order point and the y include; lead time, the economic quantity and the average time. Lead time is the time taken in receiving the delivery after the order has been placed.

**ii. Maximus Inventory Level:** The maximum inventory level is set after considering the storage capital available and its cost. The supply of capital deterioration and obsolescence and economic purchasing quantities.

**iii. Maximum Inventory Level:** Due to the fact that each item in inventory has a minimum level, the actual inventory held should not fall below this level if operations are not to be disrupted. Joseph Bagger saw minimum stock level as the buffer stock. He stated that the minimum stock is consumption during emergency period the minimum inventory level is the lowest quantity to which a particular product should be allowed to drop if deliveries are to be maintained and in arriving at this, the factors to be considered are: the length of time required for the delivery on the part of the supplies and the possibility of late deliver or delivery time accurately.

The demand for goods may fluctuate from day to day or from week to week. Also, the actual delivery time may be different from the estimated lead time. In a case where the actual usage increase or delivery of inventory is delayed, the firm can have a problem of stock-out which will be very costly to the firm. The firm or company a safety in order to guard it against inventory out.

**Optimal Inventory Levels:** The optimal inventory is the inventory that is either too large or too small that is to say it is between the maximum inventory level. The inventory level of a company depends on the nature and the volume of the operation.

**Inventory Valuation Method.** The main objective of inventory value is to produce accurate and meaningful value for purchase of product cost and income determination and this is because the different valuation methods have differed effect on a firms order.

- a) First-In-First-out (FIFO): This method implies that the oldest are issued first that is material or goods may not be issued out in this but it will be good and effective store keeping practice if this order is contained because it checks material obsolescence, deterioration and depreciation and it ensure these materials are issued out at the actual cost thereby avoiding unrealized profit or losses which may result from random issues of the materials. FIFO method does problem in time of prices being changed because the cost of goods sold is likely to be underestimated during inflation as old prices are adopted to value the materials used.
- b) Last-in-first-out: This method is an opposite of the FIFO method because it implies that the latest materials received are issued out first thereby leaving oldest in inventor and this means that the materials which are issued for production charged on the recent process while the inventory on hand is valued at the prices. The current production cost are simultaneous with the current sales revenue in order to obtain a realistic profit of the current period and this is because the most important advantage of this method is that it has the ability to give the most current cost of a product since the materials used are charged at the current prices, the disadvantages of this method that the oldest materials are left in inventory thereby exposing them to risk of loss through obsolescence, deterioration or depreciation.

- c) Base inventory method: This method is not an independent because it makes use of the both FIFO and LIFO method. The base stock method, according to Zipkin (2009), implies a fixed minimum stock carried at the original cost. He said it should be set aside and should be issued out when an emergency situation arises. Except the minimum of buffer inventory, the subsequent materials received may be issued and charged on the basis of any inventory valuation method.
- d) Standard price method: This method uses a predetermined price of pricing all the materials that are issued out. The standard prices may be set over a given period of time after all factors which affects prices may result in profit if the actual material price is low and it may also result if the reverse is the case. The main objective of the standard price is to ensure the efficiency in the purchase of materials. Most times it is difficult to establish an acceptable standard price of materials.
- e) Average price method: This method is the weighted average which determines the unity price by dividing the total cost by the quantity materials issued are charged on the average and this price makes the cost materials.

### **Inventory Accounting System**

Store accounts facilitators materials cost in two ways. They provide prices by which any particular item can be calculated. Secondly, a comparison of the total value of materials charges to various activities provides a check that all the materials have been properly analyzed effective inventory accounting system facilitates the provision of relevant inventory data to the management in determining the number of inventories at the end of each accounting period and it minimized efforts used in processing. Accountants are needed in inventory management because of the important role of the inventory accounting system in inventory management. The counting system provides useful and accurate figures to managers for adequate inventory valued. The accounting system gathers and transmits data to the inventory managers to enable him to carry out his duties effectively and efficiently.

### **Profitability Measurement**

Anyanwu (2003) defined profit as the excess of total revenues over total costs or excess of receipts over expenses. The measure of success in a business has been profit. It is this measure that distinguishes a business from all other forms of social organizations such as government, the armed forces, non-profit making organizations, etc. Boderhom (1998) in Egai and Ajie (2008) defined profit in connection with a particular time and period, and deflects some of the activities of the firm during the period. He then considered it in terms of the first three concepts relating to the status of firms at the beginning and ending of the period. They are as follows:

1. Stockholder's Initial Investments: This is the market value for the stock at the beginning of the period. It is the stakeholder's investment in the sense that it represents what the stakeholder could get by selling their shares at the beginning of the period, and is the amount of their wealth, which they have entrusted to the firm for the period.
2. Stockholder's expected end of period wealth: At the start of the period, the stakeholders expect that their initial investment will yield a return during the period. Their expected end of the period wealth  $E(W)$  consists of the expected net cash flow



- of the period,  $nl$  plus the expected end-of -period Inventory value. This means that the expected return during the period is normal rate of return on the Initial Investments as given by the discount rate.
3. Stakeholder's actual end of period wealth: This is the cash flow that actually takes place during the period,  $CL$  plus the actual Inventory value at the end of the period, i.e., the investment that the stockholder carried over into the next period.
    - i. The cash flow of the period is different from what has been expected.
    - ii. The cash flow expected in the future periods has changed since the start of the period.
    - iii. In a world of certainty where expectations always come true and are never changed, actual wealth would increase from period to period by the discount rate multiplied by the actual investment.

The above analysis throws light on the varied definitions of pure profits by economics, business-men and accountants. The normal economist usually defines pure profit as a return in excess of the normal or invested capital which in the case is the discount rate since the normal return is regarded as the cost.

### **Methodology**

The research Philosophy adopted here in this study is the qualitative and idiographic methodology. which emphasizes on inferences based on deductive analysis, and also attempts to identify the evidence of validity across various studies which have examined related variables within other contexts using similar tools and statistical techniques. The qualitative method was considered suitable as it offers the study the avenue for cross-assessment of findings alongside the evidence presented in other studies. *The* qualitative method of data was collected a to play supportive role in the formulation of conclusion and recommendation

### **Conclusion**

Base on the above findings, the following conclusion were made; effective inventory management oof finished goods leads to profitability manufacturing firms. Finally, we concluded that inventory management have significant effect on the profitability of manufacturing company in Nigeria.

### **Recommendations**

Since manufacturing company cannot regulate the importance of evolving, and maintaining effective inventory control system, there are needs for them to adopt a proactive attitude towards the issue. Being proactive requires maintenance of a right level of inventory at any point in time. Organizations should avoid the dangers that are inherent to little or too much of stock. Manufacturing company in Nigeria should develop a policy framework to facilitate faster implementation of best inventory management practices. Manufacturing companies should adopt the inventory keeping method that best suits their operations and also prevent stock-outs. There is also the need for organizations to train their personnel in the area of inventory control management. What this means is that only trained professionals with the required professional skill takes charge.



## Reference

- Augustine, A. N. & Agu, O. A. (2003). *Inventory management on organizational effectiveness information and knowledge management*, 3(8) 92-100
- Aniogu, O. E. (2011). *Elements of production management*, Enugu; Ktek Publishers
- Aliyaniou, J. C. (2005). *Monetary economic theory, policy and institutions*, Onitsha: Hybrid publishers
- Falope, O. I. & Ajirole, O. T. (2009). Working capital management and corporate profitability; evidence from panel data analysis of selected quoted companies in Nigeria, *Research Journal of Business Management* 3.73-84
- Kotter (2005). *Strengthening in purchase supplier partnership*, A Working Paper Cornell University.
- Lucy, T. (2009). *Quantitative techniques. 4<sup>th</sup> edition*, London: Ashfold Colour Press.
- Moore L.J, Lee S. M. & Taylor, D. B. W. (2003). *Management science 4<sup>th</sup> edition*, Allyn and Bacon, Needhan Heights MA.
- Noly, N. A. (2008). *Fundamentals of research in behabioural science and humanities*, Calabar: Wusas Publishers.
- Ogbe A. L. Onyekanma & ukpere, W. L. (2004). The impact of inventory control management on organizational performance, *Mediterranean Journal of Social Science*, 5 (10) 109-118.
- Vichery (2009). *Cost accounting: A managerial emphasis*, New Delhi: Practice Hall International Publishers.



## HARNESSING THE SIGNIFICANCE OF EFFECTIVE TAX ADMINISTRATION FOR TAX INCOME AND ECONOMIC GROWTH IN BENUE STATE

<sup>1</sup>Osayi, Valentine Igbinedion, & <sup>2</sup>Akemieyefa Matthew  
<sup>1&2</sup>Department of Banking and Finance, Federal University,  
Wukari, PMB 1020 Taraba State, Nigeria

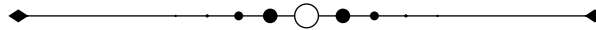

### Abstract

*This study examined effective tax administration and economic development of Benue State. The study adopted the ex-post factor design. The study covered Benue State Economy with data obtained from the state Board of Internal Revenue for the period of 32 years (1989-2019). Data collected were analyzed using the Ordinary Least Square Regression (OLS) with the aid of Eview 8.0. It also used descriptive statistics to evaluate the nature of data collected. The study's findings revealed that there is a significant negative relationship between Agricultural Income Tax (AIT) and Economic growth of Benue state as well as no significant relationship between Company Income Tax (CIT) and economic growth of Benue state within the period under focus. The study recommended that Benue State Government should as a matter of urgency formulate and review the existing agricultural tax policy to enhance adequate collection of Agricultural Income Tax (AIT) in Benue state. Also, the study recommends that the relevant authority in Benue state such as the Benue Inland Revenue Service (BIRS) should review the Company Income Tax policy of the state such that would attract many companies into the state. This would boost the collection of company income tax in the state and would go a long way in boosting the internally generated revenue through taxation.*

**Keywords:** Agricultural Income Tax, Custom and Excise Duties, Company Income Tax.

---

### **Background to the Study**

The level of economic growth and development of nation depends on the amount of the revenue generated and channeled towards the development of the country. One of the sure ways of generating revenue is through tax. A country's tax system is a major determinant of the macroeconomic indexes for developed and developing economies; hence, there exist a relationship between the tax structure and the level of economic growth (Libabatu, 2014). According to Kiabel (2009) and Vincent, (2001), there is a strong relationship between the level of economic growth, tax base and tax policy objectives which vary with the stages of development. Similarly, the economic criteria by which a tax structure is to be judged and relative importance of each tax source vary over time (Vincent, 2001). Using tax as a source of revenue generation in financing development activities in Nigeria has been a difficult issue primarily because of various forms of resistance, such as evasion, avoidance and corruption in the administration. These activities are considered as sabotaging the economy and government readily present them as reasons for the underdevelopment of the country.

The purpose of government among others is to provide basic amenities, protect the lives and property of the citizens and create the enabling environment for individual and corporate organization to strive. However, for the government to carry out this responsibility, it needs to mobilize revenue through taxation of the citizens and corporate organization. Thus, the whole essence of tax is to generate revenue which could be used to advance the welfare of the citizen and to regulate the economy (fiscal policy). While taxation plays a significant role in income redistribution, protection of weak and infant industry, the revenue generated through it plays a crucial role in promoting economic growth and development. However, if the tax is poorly administered the revenue generated will not contribute much to economic growth and development.

All levels of governments in Nigeria do no longer perform their responsibilities simply because of financial crisis experienced from internally generating revenue. This bad financial situation is further aggravated by the prevailing inflationary situation in this country which erodes the value of funds available to render essential social service to the people. Okafor, (2012) and Sanni (2007) advocated the use of tax as an instrument of social engineering, to stimulate general and/or sectoral economic growth. In that regard, taxation could have a positive or negative effect on both the individual and the government. This is because the bulk of revenue needed for development purposes is derived from oil. Crude oil export has continued to account for over 80% of the total federal government revenue, while the remaining 20% is contributed by nonoil sector in previous years (Oduola, 2006).

In Nigeria, tax revenue contributes the highest revenue to the federation account which is shared by the three tiers of government- federal, state and local governments. The tax system is structure in line with the fiscal power of the tiers of government with each having different tax jurisdictions. However, as observed by Oduola (2004), the tax system is lopsided and dominated by oil revenue which accounted for at least 70% of the revenue; this indicates that traditional tax revenue has never assumed a strong role in the country's management of fiscal policy. Revenue generated through tax has not met the expectation of government. Government has equally expressed this disappointment and is working towards expanding the non-oil tax revenue (Festus & Samuel 2007). It is in the light of the foregoing that this study examines the extent to which tax revenue has contributed to economic growth of Benue State.

## **Literature Review**

### **Conceptual Review**

Tax is a compulsory levy imposed by the government of a country or its appropriate agency on taxable persons, individuals, businesses and other bodies to allow the government to source money needed for the provision of infrastructural development. The Institute of Chartered Accountants of Nigeria (ICAN) (2006) and the Chartered Institute of Taxation of Nigeria (CITN) (2002) viewed tax as an enforced contribution of money, enacted pursuant to legislative authority. It therefore means that if there is no valid statute by which it is imposed; a charge is not a tax. On the other hand, tax revenue is seen as the income that is generated by government agency through the implementation of the various tax policies of government. According to Anyanwu, (1997), tax revenue is the compulsory transfer of payment (or occasionally of goods and services) from private individuals, institutions or groups to the government. Tax revenue on purchase comes in two forms: it can be as a percentage of the price added to purchases, such as sale tax in the U.S and VAT in the UK, which are also administered in Nigeria, and “Duties” which are a fixed amount added to the purchase price.

There are various forms of taxation from which government generates its revenue from but the potentials inherent in agricultural income tax for which Benue state government stands to gain huge advantage because of the agricultural opportunities available in the state is yet to be fully harnessed for the benefits of the mass of the people. Agricultural income tax is administered and collected by the local financial departments and the local tax bureaus. The revenue collected belongs to local government. According to the regulations on agriculture tax, the people’s government at the provincial level may, upon approval by the people congress at the same level, collect this surtax for the public benefit of the local populace.

### **Overview of the Nigerian Tax System and Structure**

Tax revenue has been in existence even before the Amalgamation of Nigeria as a political entity in 1914. Direct taxes, which were introduced into the northern part of Nigeria, were successfully administered because the citizens were already used to one form of tax or another before the formalization of direct taxes. With the amalgamation of the North and the South in 1914, direct tax revenue was introduced into Western region in 1916 and into the Eastern provinces around 1927. The enabling laws and regulations were fashioned after those of Britain. The two major legal bodies connected to the administration of company income tax, petroleum profit tax, and personal income tax, value added tax, withholding tax, education tax and custom excise duty in Nigeria are Joint Tax Board (JTB) and Federal Inland Revenue service (FIRS). The Joint Tax Board was established in 1961 to offer advice and coordinate various aspects of tax revenue and also to promote uniformity both in the application of personal income tax Act 1993, and in the incidence of tax on individual throughout Nigeria. The Company Income Tax Act (CITA) 2004 further confirmed that FIRS is established to carry out the following functions: to exercise the powers and duties conferred on it by any enactment of the Federal Government in respect of the above mentioned taxes; to advise the Federal Government on request on double tax revenue arrangement; to promote uniformity both in the application of the personal income tax Act 1993 and the incidence of tax on individual; to advise the Federal government on request on capital allowances rate and other tax revenue matters, and to impose its decisions on matter of procedure and interpretation of the PITA 1993 on any state of the Federation for the purposes of conforming to such agreed interpretation. The Federal Board of Inland Revenue was established with the power to administer Company Income Tax Act (CITA) 1990. The operational arm of FBIR is the

Federal Inland Revenue Service (FIRS) which was established in 1993. FIRS have the responsibility of income tax assessment, collection, accounting and administration.

The Nigerian tax system has experienced series of reforms since 1904 to date. The effects of various reforms in the country are as follows: introduction of income tax in Nigeria between 1904 and 1926; grant of autonomy to the Nigeria Inland Revenue in 1945; the Raisman Fiscal Commission of 1957; formation of the inland Revenue Board in 1958; the promulgation of the Petroleum Profit Tax Ordinance no. 15 of 1959; the promulgation of the Companies Income Tax Act (CITA) 1979; establishment of the Federal Inland Revenue Service (FIRS) between 1991 and 1992; and tax policy and administration reforms amendment 2001 and 2004 Ogbonna & Ebimobwei (2011).

### **Tax Administration in Nigeria**

Successive governments have expressed concern over the low level of revenue generated by the Nigerian tax system. This has been attributed largely to the deficiencies in the tax administration system, complex legislation, and apathy (Ndekwa, 1991; Ariyo, 1997). In order to make the administration of tax system effective, many developing countries undertook tax reforms in the 1980s. According to Ola (2006) tax administration in Nigeria does not measure up to appropriate standard because tax is inequitable. Many of the supposed taxpayers know nothing of the rule which they are to pay tax or the range of deductible expenses and the allowance available to them; they cannot be at ease to disclose their taxable income.

According to Enegbu, Akujuobi & Appah (2011), the Nigerian tax system has undergone several reforms aimed at enhancing tax administration with minimal enforcement cost. The recent reforms include the introduction of TIN, (Tax Identification Number), which became effective since February 2008, automated tax system that facilitates tracking of tax positions and issues, by individual taxpayer, E-payment system which enhances smooth payment procedure and reduce the incidence of tax touts, enforcement scheme which engage special tax officers in collaboration with other security agencies to strict compliance in payment of taxes. Section 8(9) of Federal Inland Revenue Service (FIRS) Establishment Act 2007 has led to an improvement in the tax administration in the country, thus, the integrated tax offices and authorities now have autonomy to access, collect and record tax. According to Oni (1998), a critical challenge before tax administration in the 21<sup>st</sup> century Nigeria is to advance the frontiers of professionalism, accountability and awareness of the public on the imperative and benefit of tax revenue in national development. According to Okpe (1999), tax administration in Nigeria is guided by the following Acts and Decrees:

**Personal Income Tax Decree (1993) referred to as Decree 104 of 1993.** This governs the taxation of individual trustees, executors, partnership, communities and families.

**Company Income Tax Act (CITA) 1979 referred to as 1979 Act** which regulates the taxation of registered company.

**Petroleum Profit Tax Act (PPTA) 1959 as amended up to 1995 up to referred to as PPTA 1959 as amended.** This Act regulates the government and collection of petroleum profits tax payable by organizations that engage in the extraction and sales of petroleum products in Nigeria.



**Capital Gain Tax Decree (CGTD) 1969** which was introduced by Decree 44 of 1967. This decree takes care of gains accruing to any person on or after 1st April, 1967 on the disposal of chargeable assets.

**Value Added Tax (VAT) Decree 106 of 1993** which imposes tax on some selected goods and service manufactured in or imposed into the country. The repeated sales tax in the country.

**Education Tax Decree No 104 of 1993.** An education tax of 2% of assessable profits is imposed on all companies incorporated in Nigeria. This tax is viewed as a social obligation placed on all companies in ensuring that they contribute their quota in developing educational facilities in the country.

The study observed that the above acts and decrees as the case may be in their original state when they were promulgated. However, a number of amendments to reflect the current tune and economic realities have since been carried out on them. The principal of these amendments is contained in the Finance Acts of 2020 which was recently signed into law by President Muhammadu Buhari in 2021. Every other amendment done is predicated on these original ones.

### **Theoretical Review**

#### **Socio Political Theory**

This theory of tax revenue states that social and political objectives should be major factors in selecting taxes. The theory advocated that a tax system should not be designed to serve individuals but should be used to cure the ills of society as a whole. It is in line with this theory that Okpe (1997) describes taxes as one of the major sources of revenue for all government both in Nigeria and across the globe in order to avail it of the resources to cure the ills of the society. The taxes paid to the government come back to the taxpayers in the form of provision of social amenities by the government. Nigerian tax system is assessment imposed by the federal and state government to enable them to charge taxpayers appropriately in order that they are able to provide social services for Nigerian citizens. According to Rabni (1981), the citizens cannot provide all the social and basic amenities which are the social services that enhance their living standard; they contribute a fractional part of the huge amount used in the provision of these basic amenities through the payment of taxes and government provide the remaining part. Without the imposition of tax on individuals and companies, it would be difficult for government to provide the social services needed. According to Okpe (1997), the ways by which taxes are used in the provision of social services are:

- a. **In Funding the Education Sector:** Government uses part of the revenue from tax collected in the payment of the teaching staffs and non-teaching staffs especially in secondary schools and some tertiary institutions.
- b. **In Financing Expenditure on Health:** Taxes collected are used by the government in the payment of salaries to the doctors who work in the government hospitals, nurses and other categories of staffs that are found in the hospital.

**Agricultural Sector:** This sector is very important to the economy of every government, therefore, needs to be protected for continual existence and growth. Agriculture produces e.g. cocoa, latex, forms part of the country's export which brings about economic development. Government uses the revenue from taxes to encourage farming activities instead of



concentrating only on white collar jobs. And also, to finance the payment of Extension workers whose duty is to go about advising people on the methods of farming. There is also the Agricultural income tax mainly imposed on agricultural goods and services. Agriculture is seen as the bedrock of any economy especially in Africa (Adama, Asaleye, Oye, & Ogunjobi, 2018). Strong economies are built on its ability to explore its potentials and opportunities using natural resources, except in technologically developed countries like Japan. Agriculture plays a vital role in the national development of the economy of most developed nations. They see agriculture as a means of reducing over dependency on some particular sector or activities of the economy like oil sector. Some benefits that will accrue to such countries are increases in the rate of exportation, enhancement of foreign exchange, provision of employment opportunities, reduction in poverty levels and contribution to economic growth (Ojeka, 2016; Asaleye et al., 2018). In 1960, the agricultural sector contributed upto about 70 per cent of Nigerian exports. This later reduced to 40 per cent in the late 1970s and gradually decreased to 2 per cent in the late 1990s. In recent times, agriculture has been neglected by the majority in Nigeria. Agriculture is only practiced on a small scale in rural societies of the country. Although Nigeria has been described as one of the top countries endowed with natural resources and massive land area, only 40% of its land area is cultivated and used for agricultural purposes. There is a lack of motivation amongst the farmers due to lack/poor financing, poor transportation due to bad roads and also lack of market (people rather import foods).

**Manufacturing Sector:** Government also uses part of the taxes collected in the payment of salaries to those who work in government owned companies.

### **Empirical Review**

Several empirical studies have been conducted on the impact of taxes on economic growth with mixed findings. Among the various empirical studies are the works of Success and Ifurueze (2012) who studied the impact of petroleum profits tax on economic development (2000-2010) using the Ordinary Least Square (OLS) method of analysis and posited that petroleum profits tax has significant and positive impact on the Gross Domestic Product (GDP) used as proxy for economic growth of Nigeria. They claimed that the coefficient of determination indicates that petroleum profits tax contributes 72% to the Gross Domestic product using oil revenue and petroleum profits tax as regressors. They argued that petroleum profits tax and oil revenue are determinants of growth of the Gross Domestic Product of the Nigerian economy which will subsequently lead to economic development via the multiplier effect.

Stoilova & Patonov (2012), also examined the impact of taxation on economic growth in 27 European Union countries, using data for the period 1995 – 2010. They discovered that; direct tax revenue made more efficient impact on economic growth in EU countries than indirect taxes. Also, Ogbonna & Appah (2012) investigated the impact of tax reforms on economic growth in Nigeria using data collected from the Statistical Bulletin of the Central Bank of Nigeria (CBN) for the period 1994 - 2009. They found that, tax reform variables such as petroleum profit tax, companies' income tax, value-added tax, education tax, personal income tax, and custom and excise duties had significantly impact on economic growth in Nigeria.

Umoru & Anyiwe (2013), investigated the correlation between the New National Tax Policy and economic growth in Nigeria using co-integration technique and error correction model to analyze data. The results of their analysis revealed that, direct taxation revenue had significant positive relationship with economic growth, while indirect tax revenue had no significant but negative impact on economic growth in Nigeria.

Ihenyen and Mieseigha (2014), examined taxation as a financial instrument for economic growth in Nigeria using data obtained from the Central Bank of Nigeria for the period 1980 – 2013. They employed Ordinary Least Squares technique (OLS). The results revealed that, corporate income tax and value-added tax impacted positively on Gross Domestic Product (GDP).

In a similar study, Edame & Okoi (2014), examined the impact of taxation on investments and economic development in Nigeria, using data covering the period 1980 – 2010. They discovered that, corporate income tax and personal income tax were negatively related to investment, but positively related to government expenditure. Chude & Chude (2015) also investigated the impact of company income tax on the profitability of brewery companies in Nigeria. The work revealed that, there was a positive correlation between taxation and profitability.

Ayuba, (2014), investigated the impact of non-oil tax revenue on economic growth in Nigeria, using secondary data collected from the CBN Statistical Bulletin from the period 1993 - 2012. His results showed that, non-oil tax revenue impacted positively on economic growth in Nigeria. Ofoegbu (2016), studied empirical analysis of effects of tax revenue on economic development of Nigeria using annual time series data for the period 2005 - 2014. They discovered that, there was a significant relationship between tax revenue and economic development. The results also revealed that, measuring the effects of tax revenue on economic development using Human Development index (HDI) gave lower relationship than measuring the relationship with GDP gives a painted picture of the relationship between tax revenue and economic development in Nigeria.

Cornelius, Ogar & Oka (2016), examined the impact of tax revenue on the Nigerian economy. The study covered the period from 1986 to 2010 using CIT, PPT and NOR as independent variables against GDP. Their findings revealed that, there was a significant relationship between petroleum profit tax and the growth of the Nigeria economy. It also showed that, there was a significant relationship between non-oil revenue and the growth of the Nigeria economy. They found that, there was no significant relationship between company income tax and the growth of the Nigeria economy. Abata (2014) wrote on the impact of tax revenue on Nigeria economy using descriptive survey design and simple random sampling technique. His findings revealed that, tax revenue has a significant impact on Federal Government Budget implementation and revenue generated in Nigeria.

In a related study, Ogbonna & Appah (2016) investigated the effects of tax administration and revenue on economic growth of Nigeria. Data collected from the questionnaires and secondary data were analyzed using relevant regression analysis. Their results revealed that, there was a significant relationship between the following: Personal income tax revenue (PITR) and per capita income; Company income Tax Revenue and Gross Domestic product

of Nigeria; VAT revenue and PCI of Nigeria, Petroleum Profit Tax revenue and GDP of Nigeria

**Methodology**

**Research Design:** The study adopts the longitudinal causal research design. This involves collecting data for a long period of time and measure the effect of the independent variables on the dependent variable. In this case, the various forms of tax will be the regressors while Gross Domestic Product (GDP) will be the regressive.

**Sources of Data:** The study utilized secondary data obtained from Federal Inland Revenue Service (FIRS), Benue Inland Revenue Service (BIRS), National Bureau of Statistics (NBS) and the Central Bank of Nigeria (CBN) Statistical Bulletin for various years.

**Model Specification:** The analytical model used in this study is based on the works of Osayi, Kasimu and Abang-Anoh (2018) as well as Ogbonna & Appah (2016) with slight modifications. Thus, the functional relationship between effective tax administration and economic development in Benue State is specified below:

$$GDP = f(AIT, CED, CIT) \dots \dots \dots (1)$$

The econometric form of the model is specified thus:

$$GDP = \beta_0 + \beta_1 AIT_t + \beta_2 CED_t + \beta_3 CIT_t + \mu \dots \dots \dots (2)$$

Where:

- GDP = Gross Domestic Product
- AIT = Agricultural Income Tax
- CED = Customs and Excise Duties
- CIT = Companies Income Tax
- $\mu$  = Stochastic error term.
- $\beta_0$  = Constant
- $\beta_1, \beta_3$  are beta weight or regression coefficient

The coefficients of all the explanatory variables are expected to be either positive or negative, depending on the peculiarity of the state's tax structures. The intercept term is expected, *a priori*, to be positive as tax variables are not the only contributors to the state's economic growth rates.

**Data Analytical Technique:** The study conducted the descriptive statistic test as well as the Augmented Dickey Fuller (ADF) unit root test for the normality and stationarity of the series respectively. With the aid of Eview 8.0 econometric software, the Least Square Method (LSM) of linear regression model was used to analyze the impact of Effective Tax Administration and Economic Development of Benue State in Nigeria. The Ordinary Least square regression used in this study help to predict the behavior of the dependent variable upon the manipulation of the independent variables.

**Descriptive Statistics:** The individual descriptive statistic for Gross Domestic Product (GDP), Agricultural Income Tax (AIT), Custom and Excise Duties (CED) and Company Income Tax from 1989- 2019.

### Descriptive Statistics

Table 1 below shows the individual descriptive statistic for Gross Domestic Product (GDP), Agricultural Income Tax (AIT), Custom and Excise Duties (CED) and Companies Income Tax (CIT) from 1989-2019.

**Table 1: Descriptive Statistics**

	GDP	AIT	CED	CIT
Mean	579367.3	2813.516	30274.00	26548.39
Median	527576.0	2887.000	8787.000	25823.00
Maximum	999765.0	3252.000	98927.00	35050.00
Minimum	262250.0	2141.000	1758.000	24952.00
Std. Dev.	284239.7	430.2244	39072.84	2381.966
Skewness	0.299210	-0.503817	1.076707	2.645435
Kurtosis	1.454627	1.644709	2.211065	9.640148
Jarque-Bera	3.547283	3.684015	6.793659	93.10962
Probability	0.169714	0.158499	0.033479	0.000000
Sum	17960385	87219.00	938494.0	823000.0
Sum Sq. Dev.	2.42E+12	5552792.	4.58E+10	1.70E+08
Observations	31	31	31	31

**Source:** Researcher's computation, 2021 using Eview 8.0

From the descriptive statistics in table 1 above, GDP has a mean value of 579367.3; AIT has a mean value of 2813.516 while CED and CIT have means values of 30274.00 and 26548.39 respectively. All these show the average returns of the variables within the period. The median values as shown in the table reveal that the variables are distant from the averages except AIT. This means that there is a high degree of disparity among the data within the period. The standard deviation also confirmed this as low values in relation to the mean suggest low degree of variation of the data over the period, while high values mean high variation of the data within the period. As for the skewness of the distribution, all the variables are positively skewed except AIT, indicating that values for the respective variables lie to the left of their respective means. The kurtosis of the distribution shows that it only CIT that is leptokurtic (Fat tail) as its value is more than three (3); while GDP, CED and CIT are platykurtic (flat tail) as their values are less than three (3). The J-B values for the variables are low except for CIT and they all pass the test of significance at the 5 percent level except CED and CIT.

### Unit Root Test

The unit root test was conducted using the Augmented Dickey-Fuller (ADF) test to find out whether the variables exhibit unit roots property. The table below shows this:

**Table 2: Summary of Unit Root Test Results**

Variables	ADF Test Statistic	95% Critical ADF Value	Order of Integration	Remarks
GDP*	-5.158124	-2.967767	1(1)	Stationary
AIT*	-5.185315	-2.967767	1(1)	Stationary
CED*	-10.90424	-2.967767	1(1)	Stationary
CIT*	-4.498885	-2.963972	1(1)	Stationary

**Source:** Researcher's computation, 2021 using Eview 8.0\* indicates significant at 5% levels.

From the table above, it is seen that all the variables are stationary at first difference except for CIT which is stationary at levels. This is confirmed from the ADF statistic which is greater than the 95% critical ADF values for all the variables. This shows that the time series properties of the data were relatively stable as there is no biasedness of information, indicating that the result is reliable.

**Table 3: Model Estimation and Interpretation**

Dependent Variable: GDP				
Method: Least Squares				
Date: 06/18/21 Time: 15:05				
Sample: 1989 2019				
Included observations: 31				
Variable	Coefficient	Std. Error	t-Statistic	Prob.
C	769141.1	300002.9	2.563779	0.0162
AIT	-245.0390	53.52269	-4.578228	0.0001
CED	5.857824	0.618455	9.471701	0.0000
CIT	12.14038	10.14943	1.196164	0.2420
R-squared	0.823231	Mean dependent var		579367.3
Adjusted R-squared	0.803590	S.D. dependent var		284239.7
S.E. of regression	125969.8	Akaike info criterion		26.44539
Sum squared resid	4.28E+11	Schwarz criterion		26.63042
Log likelihood	-405.9035	Hannan-Quinn criter.		26.50570
F-statistic	41.91396	Durbin-Watson stat		2.100525
Prob(F-statistic)	0.000000			

**Source:** Researcher's computation, 2021 using Eview 8.0

### Interpretation

From the regression result above, it can be seen that the R-square of 0.82 is very high, revealing that 82 percent of the systematic variation in the rate of taxation and Economic Development of Benue state is captured by the model. The model could not capture the other 18 percent. The adjusted R-square of 0.80 is also very high, implying that the model has 80 percent predictive ability. The Durbin Watson (DW) statistic of 2.1; which is squarely within the acceptable range shows the overall performance of the model and shows that there is no serial correlation.

### Empirical Validation of Hypothesis Using t-Statistic

**H01:** There is no relationship between Effective Tax Administration and Economic Growth and Development of Benue State in Nigeria.

The estimated regression results in table 3 above show that the calculated t-statistic of 4.5782 and 9.4717 representing Agricultural Income Tax (AIT) and Custom and Excise Duties (CED) respectively are greater than the critical t-tabulated value of 2. Meanwhile, the t-statistic decision rule on test of hypothesis is to reject the null hypothesis and accept the alternate hypothesis when the computed t-value is greater than the tabulated t-value or decide otherwise when the computed t-value is less than the tabulated t-value. Hence, the study rejects the null hypothesis and concludes that there is significant relationship between



Effective Tax Administration and Economic Growth and Development of Benue State in Nigeria.

### **Discussion of Findings**

It can be seen from the result of the study that agricultural income tax has significant negative relationship with economic growth of Benue state. The relationship can best be described as negative significance as revealed in the table above. This is similar to the findings of Ayuba (2014), as well as Abata (2014) who investigated the impact of non- oil tax revenue on economic growth in Nigeria. In addition, as can be observed from the result in the table above, company income tax has a positive but not significant relationship with economic growth of Benue state. This is again similar to the findings of Cornelius, Ogar and Oka (2016) who examined the impact of tax revenue on the Nigerian economy from 1986 to 2010. Also, it was observed from the study that there is significant positive relationship between custom and excise duties and the economic growth of Benue state. The finding is contrary to Okafor (2012) who examined tax revenue generation and Nigerian economy. These findings are however not surprising, as they reflect the realities on ground. Benue state being agrarian state and the food basket of the Nation has huge agricultural potentials that are yet to be fully harnessed. A number of their agricultural products such as yams and other fruits like mangoes, oranges cannot find their way into international market as they are not well packaged and most times waste away in their raw state.

### **Conclusion and Recommendation**

The significance of effective tax administration in the growth and development of the modern economy cannot be over emphasized. This is in the light of the huge revenue generating capacity of effective tax administration can offer Benue state. Payment of taxes is a compulsory civic duty of any responsible and patriotic citizen failure of which attracts sanctions from the Government. From empirical analysis carried out, it is found out that there is strong significant relationship between agricultural income tax and economic growth and development of Benue state in Nigeria. Also found out is that there is significant positive relationship between customs and excise duties and economic growth of Benue state in Nigeria. The study also found out that there is no significant relationship between company income tax and economic growth of Benue state within the period under focus.

Based on the findings of the study, the following recommendations are therefore made;

- i. The Benue State Government should as a matter of urgency formulate and review the existing agricultural tax policy to enhance adequate collection of agricultural income tax in Benue state.
- ii. The relevant authority in Benue state such as the Benue Inland Revenue Service (BIRS) should review the Company income tax policy of the state such that would attract many companies into the state. This would boost the collection of company income tax in the state.
- iii. The Benue state Government should formulate policies and guidelines in order to further enhance the collection of custom and excise tax in Benue. This would go a long way in boosting the internally generated revenue through custom and excise tax in the state.



## References

- Abata, M. A. (2104). The impact of tax revenue on Nigeria economy (A case study of FBIR), *Journal of Policy and Development Studies* 9. (1) 109-121
- Adama, I. J., Asaleye, A. J., Oye, A. J., & Ogunjobi, O. J. (2018). Agricultural production in rural communities: Evidence from Nigeria, *Journal of Environmental Management and Tourism*, 9(3), 428-438.
- Ariyo, A. (1997). Productivity of the Nigerian tax system: 1970 to 1990, *African Economic Research Consortium*, Nairobi Kenya.
- Anyanwu, J. C., (1997). *Nigerian public finance*, Joanne Educational Publishers, Onitsha.
- Ayuba, A. J. (2014). Impact of Non-oil revenue on economic growth: The Nigeria perspective, *International Journal of Finance and Accounting*, 3(5), 303 – 309
- Capital Gains Tax Act, (1967), As amended by Decree 1998
- Central Bank of Nigeria – (2007), *Annual Report and Statistical Bulletin*
- Chartered Institute of Taxation of Nigeria CITN (2002), *Nigeria Tax Guide and Statutes*, CITN Publication
- Company Income Tax Nigeria [http://resourcedat.com/2010/12/company income tax](http://resourcedat.com/2010/12/company-income-tax) (Assessed on 12/07/12)
- Companies Income Tax. Act 2000 as amended
- Companies Income Tax (Amendment) Act, 2007
- Customs Excise Tariff (Consolidation) Amendment ACT of 1998
- Central Bank of Nigeria (2014). *Annual statistical bulletin*, Abuja: Central Bank of Nigeria
- Cornelius, M. O, Ogar, A. & Oka, F. A. (2016). The impact of Tax revenue on economic growth: Evidence from Nigeria, *IOSR Journal of Economics and Finance*. 7(1) 32-38
- Edame, G. E., & Okoi, W. W. (2014). The impact of taxation on investment and economic development in Nigeria, *Academic Journal of Interdisciplinary Studies*. 3 (4),209- 218. doi: <https://doi.org/10.5901/ajis.2014.v3n4p209>.
- Enegbu, E. C., Akujuobi, L. E., & Appah, E. (2011). An empirical study on the causality between economic growth and tax revenue in Nigeria, *Current Research Journal of Economic Theory*, 4(2), 29-38.

- Festus, A. F. & Samuel, F. A. (2007). Company income tax and Nigeria economic development, *European Journal of Social Sciences*, page 22-23.
- Ihenyen, C. J. & Mieseigha, E. G. (2014). Taxation as an Instrument of Economic Growth (The Nigerian Perspective). *Information and Knowledge Management*, 4(12): 49– 53.
- Institute of Chartered Accountants of Nigeria ICAN (2006). *Tax Management and Fiscal Policy in Nigeria* 1st edition 46-50
- Kiabel, B. & Nwokah, N. (2009). Boosting revenue generation by state governments in Nigeria: The tax consultants option revisited, *European Journal of Social Science*, 8(4), 532– 539.
- Ndekwa, E. C. (1991). *An analytical review of Nigeria's tax system and administration*, Paper presented at a National Workshop on Tax structure and Administration in Nigeria, Lagos, 15-17 May.
- Odusola, A. (2006). *Tax policy reforms in Nigeria*, United Nations University- World Institute for Development Economics Research (UNU-WIDER) Research Paper No.2006/03
- Ofoegbu, G. N. Akwu. D. O. & Olive, O. (2016). Empirical analysis of effect of tax revenue on economic development of Nigeria, *International Journal of Asian Social Science*, 6(10), 604-613
- Ogbonna, C. & Ebimobowei, E. (2012). Effect of tax policy on firm's performance in Nigeria: A study of quoted banks, *Journal of Social Sciences and Finance* 2(3).
- Ogbonna G. N, & Appah, E. (2012). Impact of petroleum revenue and the economy of Nigeria, *Current Research Journal of Economic Theory* 4(2), 11-17,
- Ogbonna, G. N. & Appah, E. (2012). Impact of tax reforms and economic growth of Nigeria: A time series analysis, *Current Research Journal of Social Sciences*, 4 (1), 62-68.
- Ogbonna, G. N. & Appah, E. (2016). Effect of tax administration and revenue on economic growth in Nigeria, *Universal Journal on Sustainable Developmental Research (USDR)*
- Ojeka, E. C. (2016). Constraints to Agricultural Development in Nigeria, *International Journal of Development and Economic Sustainability*, 1-15
- Okafor, R. G. (2012). Tax revenue generation and Nigerian economic development, *European Journal of Business and Management*, page 19.
- Olatunji, L. A, Olaleye, M. O. & Adesina, O. T. (2007). *Principles of Taxation in Nigeria. 2nd Edn*, Published by Mighty Productions, Ibadan.
- Osayi, V. I, Kasimu, A. & Abang-Anoh, C. Y. (2018). Tax revenue and economic growth in Nigeria, *Journal of Accounting and Management (JAM)*, 1(2),69-91.

Personal Income Tax (Amendment) Act, 2011

Personal Income Tax Act 1993 as amended by Acts 1996 and 1998

Personal Income Tax (Amendment) Act. 2005

Success, M., Success, E. & Ifurueze, M. (2012). Impact of petroleum profits tax on economic development of Nigeria, *British Journal of Economic Finance and Management Sciences*, 5(2), 60–70.

Vincent, O. O. (2001). Fiscal federalism: The Nigerian experience, *Public Lecture Series*, 4, NES.  
44



## SPACE AND SPATIALITY AS SEMIOTIC TOOLS FOR BUILDING AN ADMIRABLE COMMUNITY

**Samaila Yakubu**

*Department of English and Literary Studies  
Federal University Wukari, Taraba State*

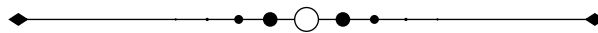

### **Abstract**

*Didan community is well built since members of the public deployed space and spatiality to create space between their domiciles and environs. They deploy space and spatiality to create space between their domiciles and domicile of head of the community, to create space between individual domiciles, to create space between their domiciles and town hall, to create space between their domiciles and police station, to create space between their domiciles and community secondary school, to create space between their domiciles and community toilets, to create space between their domiciles and community borehole. Moreover, they employ space and spatiality to create space between their domiciles and market square, to create space between one stall and another, to create space between their domiciles and community garden, to create space between different age groups, and between individuals in each group during social gathering. Furthermore, Ayirikpu cult also deploys space and spatiality to create space between domiciles of its leader and members, to create space between domiciles of its members, to create space between domiciles of its members and non-members, to create space between groups and between individuals in each group during ceremony or rituals. Space created between domiciles of members of the community and environs, between different groups, and between individuals during ceremonies includes close space of personal distance, close space of social distance, space management, public close distance, public close space, and public far space. The study concludes that space and spatiality are best tools for building fine communities*

**Keywords:** *semiotic analysis, space, spatiality, Ayirikpu cult, Didan Community, Domicile.*

## **Introduction**

Didan community is admirable. Members of the public deploy space and spatiality to create space between their residences and residence of community head, to create space between their residences, to create space between their residences and town hall, to create space between their residences and police station, to create space between their residences and community secondary school, to create space between their residences and community toilet, to create space between their domiciles and community borehole. Besides, they deploy space and spatiality to create space between their residences and market square, to create space between one stall and another, to create space between their residences and community garden, to create space between age groups, and between individuals in each group during social gathering. Furthermore, Ayirikpu cult also employs space and spatiality to create space between the residence of its leader and other members of the cult, to create space between domiciles of its members, to create space between domiciles of its members and non-members, to create space between groups and between individuals in each group while performing ceremony or ritual. The cult defends the territory where it performs its ceremony or ritual against intruders. To buttress this fact, Tuan (1997) asserts that space is a place that belongs to someone and is defended against intruders. This assertion indicates that space is an area which belongs to somebody and is protected against encroachers. Any non-member of the cult who encroaches into the territory of Ayirikpu cult is warned to go back, if he insists to proceed, he is attacked.

## **Space**

The Britannica dictionary defines space as “the amount of an area, room, surface, etc, that is empty or available for use” (“space”, n.d.). This definition suggests that any place, room or surface which is uninhabited or accessible to the people can be described as space. The dictionary further explains that space is “an area that is used or available for a specific purpose” (“space”, n.d.). This description connotes that space is a place which is utilised or is ready for use. Moreover, it describes space as “an area of land with no buildings on it.” This definition indicates that any land which people have not built anything on it can be described as space. Oxford learner dictionaries define space as “an amount of area or of a place that is empty or that is available for use” (“space”, n.d.). This definition implies that a place which is vacant and is at one’s disposal can be explicated as a space. It further describes space as “a place, especially a room or a building that can be used for a particular purpose.” (“space”, n.d.). Any point, chiefly an erection or structure which can be utilised for a specific motive is described as space. Cambridge dictionary described space as the place which is around everything which exists. This definition connotes that any area which is around everything that exists can be called space. Longman dictionary of contemporary English defines spaces as “an empty place between two things or between two parts of something” (“space”, n.d.). This definition suggests that space is a vacant area between two entities or between two components of something. Sultana (n.d) says that space is often regarded as an area which has link to ownership. This assertion suggests that space is a place which has its owner. According to Gaines (2006), semiotics of space is a procedure of exploring the relationship between objects and their spatial contexts. This assertion indicates that

semiotics of space is concerned with the process of investigating the relations between objects and their spatial contexts.

### **Spatial**

Spatial concept (n.d.) explains the relationship between us and objects along with the relationship of objects to each other. It points out further that as our knowledge starts to grow in early life, spatial concepts like in front of, behind, top, bottom, over, under, last, between, furthest, in, background, on, etc, assist us to grasp directions more precisely, ask detailed questions and communicate our ideas to other people. Mcgregor (2004) describes spatiality “in terms of relationship between different kinds of space and place, including the network spacer of relations and objects” (p.348). This definition implies that spatiality can be described with respect to relationship between various types of space and place as well as interrelation between space and objects. Vocabulary dictionary points out that spatial explicates how objects fit together in space whether among the planets or here on earth. Cambridge dictionary defines spatial as something “relating to the position, area and size of something (“spatial”, n.d.). This definition connotes that spatial relates to location in which something is, the region where it is and the size of the thing. Schulze (2014) describes spatial analysis as methods for studying the location, distribution and relationship of spatial phenomena. This description suggests that spatial analysis explicates methods for studying the location, distribution and relations of spatial phenomena. According to Kabayashi (2017), space and spatiality are historical concepts which deal with the relationship between people and things. The concepts space and spatiality are concerned with the relationship between human beings and objects. Hollink et al (2004) view spatial as the description of objects in their locations. Spatial is the explication of objects in their positions and spatial relations between the objects. Eco (as cited in Remm, 2011) asserts that the space of city is semiotic; meanings are allocated to it, spatial forms are created to indicate their functions. This assertion connotes that the area of the city is semiotic; semantic imports are assigned to it, spatial shapes are generated to indicate their roles.

### **Method of Data Collection**

The researcher used two methods to collect data for this study. One of the methods he used is the interview method. Interview simply means the techniques used by a researcher to collect information from others in a face-to-face contact. Another method which the research employed to collect data for this research is the observation method. Observation simply means an act of watching or noticing things happening.

### **Data Collection**

The researcher did not find it easy to collect data pertaining to Ayirikpu cult. He tried his best to record the responses of the interviewees on his android phone, it proved abortive because members of the cult who were supposed to grant the interview refused to allow the researcher to record their responses on his android phone. The interviewees insisted that they would only grant interview if their responses would be written down rather than recorded on android phone. The researcher had to yield to their demand as he had no power



to compel them to act according to his wish. Moreover, the interviewees warned that they would not respond to questions which would land them in trouble. They pointed out to the researcher that it was dangerous for them to reveal what they do among themselves to a non-member. The researcher pointed out to the interviewees that the study was purely an academic exercise nothing else. However, they were reluctant to grant him interview. He pleaded with them again and again and bought local alcoholic drink called Burukutu for them before they granted him interview. The researcher conducted the first interview with three elderly members of the cult on rituals performed in the forest and wrote down their responses in his jotter. The researcher was not allowed to move from one residence of the cult member to another to conduct interview rather he was allowed to conduct interview with the cult members elsewhere within the residence of one of their leaders. He conducted the second interview with three other members of the cult on the rituals performed at home and wrote down their responses in his jotter. In all, the researcher interviewed six members of Ayirikpu cult made of six men.

The researcher observed space between domiciles of members of the public and the domicile of community head, space between domiciles of members of the public, space between domiciles of members of the public and town hall, space between domiciles of members of the public and police station, space between residences of members of the public and community secondary school, space between residences of members of the public and pit toilets, and space between residences of members of the public and community borehole. Moreover, the researcher observed space between members of the public and markets square, space between one stall and another, space between domiciles of members of public and gardens, space between different age group and spaces between individuals in each group during social gathering. Besides, he observed cult members carry food and local alcoholic drink (burukutu) to the forest, he observed the cult members during marriage and naming ceremonies as well as funeral rites as they sit group by group and individually. Further, he observed space between the domicile of the cult's leader and members, space between domiciles of the cult members and non-members. He also observed group of dancers and individual dancers during ceremonies.

### **Discussion of Data**

Members of the public in Didan community deploy space and spatiality to create space between their residences and the residence of the community head. The lengths of space between the residence of the community head and the residences of members of the public is twenty-eight feet. Public far space is deployed to create space between the residence of the community head and members of the public as the length of space between their residences and the residence of community head is twenty-eight feet. Space and spatiality are deployed by members of the public to create space between their residences and town hall. The width of space between their residences and town hall is twenty to twenty-five feet. Public close space is deployed to create space between their residences and town hall as the width of space between their residences and town hall is twenty to twenty-five feet. Members of the public in Didan community deploy space and spatiality to create space between their residences

and police station. The length of space between their residences and police station is twenty-eight feet. Here, public far space is deployed to create space between their residences and police station since the length of space between their residences and police station is twenty-eight feet.

Besides, space and spatiality are deployed to create space between residences of members of the public and secondary school in the community. The length of space between their residences and the secondary school is twenty-eight feet. Here, public far space is deployed to create space between the residences of members of the public of this community and secondary school as the length of space between their residences and secondary school is twenty-eight feet. Members of the public deploy space and spatiality to create space between their residences and community toilet. The width of space between their residences and community toilet is twelve to fifteen feet. Public close space is deployed to create space between residences of members of the public and the community toilet since the widths of space between their residences and community toilet is twelve to fifteen feet. Space and spatiality are deployed to create space between the residences of the members of the public and community borehole. The length of space between residences of members of the public and the community borehole is twenty to twenty-five feet. Public close space is deployed to create space between residences of members of the public and community borehole since the length of space between their residences and borehole is twenty to twenty-five feet

Moreover, members of the public in Didan community deploy space and spatiality to create space between their domiciles. The width of space from one domicile to another is six feet. Close space of social distance is deployed to create space between domicile of one member of the public and another since the width of space from one residence to another is six feet. Members of the public employ space and spatiality to create space between their residences and market square. The width of space between their residences and market square is eight to twelve feet. Space arrangement is deployed to create space between residences of members of the public and market square since the width of space between their residences and market square is eight to twelve feet. Members of the public in the community deploy space and spatiality to create space between one stall and another. The length of space between one stall and another in Didan community is six feet. Close space of social distance is deployed to create space between stalls as the distance from one stall to another is six feet.

Equally important, members of the public in this community deploy space and spatiality to create space between their residences and community garden. The length of space between their residences and community garden is twenty-eight feet. Public far space is deployed to create space between residences of members of the public of this community and community garden as the length of space between their residences and community garden is twenty-eight feet. Space and spatiality are deployed by members of the public of the community to create space between different age groups during social gathering. The width of space between one group and another is six feet. Here, close space of social distance is deployed to create space between groups as the distance between one group and another is

six feet. Members of the public of this community also employ space and spatiality to create space between individuals in each group during social gathering. The width of space between one person and another during social gathering is one and half to three feet. Close space of personal distance is deployed to create space between individuals since person since the width of space between one person and another in each group is one and half to three feet.

Likewise, Ayirikpu cult employs space and spatiality to create space between its members and non-members when they carry food and local alcoholic drink (burukutu) to the forest. The length of space between the cult members and non-members when they carry food and drinks to the forest is twenty-eight feet. Public far space is employed by the cult members to create space between their members and non-member as the length of space between their members and non- members is twenty-eight feet. Space and spatiality is deployed by the cult to create space between groups when it performed rituals. The width of space between one group and another is six feet. Close space of social distance is deployed to create space between groups as the width of space from one group to another is six feet. Space and spatiality are also deployed by the cult to create space between individuals in each group while performing rituals. The width of space between one member and another is one and half to three feet. Close space of personal distance is deployed to create space between individuals in a particular group as the width of space between one member and another is one and half to three feet.

In addition, Ayirikpu cult employs space and spatiality to create space between groups of dancers. The width of space from one group of dancers to another is six feet. Close space of social distance is employed to create space between groups of dancers as the width of space between one group and another is six feet. The cult deploys space and spatiality to create space between individual dancers. The width of space between individual dancers in each group is one and half to three feet. Close space of personal distance is deployed by the cult to create space between individual dancers since the width of space from one dancer to another is one and half to three feet. The cult deploys space and spatiality to create space between members while performing marriage and naming ceremonies. The width of space from one member to another is one and half to three feet. Close space of personal distance is employed by the cult to create space between members as the distance from one member to another is one and half to three feet. The cult employs space and spatiality to create space between residence of its leader and members. The length of space between the residence of cult's leader and the residences of the members is twenty to twenty-five feet. Public close space is deployed to create space between the residence of cult leader and the residences of the members as the width of space between the residence of the cult's leader and the residence of the members is twenty to twenty-five feet.

Again, Ayirikpu cult employs space and spatiality to create space between residences of its members. The distance between residence of one member and another is six feet. Here, close space of social distance is employed to create space between residences of its members as the

distance from residence of one member to another is six feet. The cult deploys space and spatiality to create space between residences of its members and residences of non-members. The width of space between the residences of members and residences of non-members is twenty to twenty-five feet. Public close space is employed to create space between residences of members of Ayirikpu cult and residences of non-members as the width of space between residences of members of the cult and non-members is twenty to twenty-five feet.

Furthermore, the cult deploys space and spatiality to create space between groups during funeral rite. The width of space from one group to another is twelve to fifteen feet. Public close distance is deployed to create space between groups during funeral rite as the distance from one group to another is twelve to fifteen feet. The cult also deploys space and spatiality to create space between individuals in each group during funeral rite. Close space of personal distance is deployed to create space between individuals in each group as the distance from one member to another is one and half to three feet. The cult creates space between the point where it performs rituals and danger zone. If a non-member intrudes into the danger zone, he is warned to go back. If he proceeds to the point where rituals are performed, he is attacked. The distance between the point where rituals are performed and danger zone is twenty-eight feet. Public far space is deployed to create space between the point where rituals are performed and danger zone as the width of space between the point and danger zone is twenty-eight feet.

### **Findings**

The researcher noticed that members of the public in Didan community deployed space and spatiality to create space between their domiciles and domicile of community head, to create space between their domiciles, to create space between their domiciles and town hall, to create space between their domiciles and police station, to create space between their domiciles and community secondary school, to create space between their domiciles and community toilet, to create space between their domiciles and community borehole. Moreover, they deploy space and spatiality to create space between their domiciles and the market square, to create space between one stall and another, to create space between their domiciles and community garden, to create space between age groups, and between individuals in each group during social gathering. Besides, the researcher found that Ayirikpu cult employed space and spatiality to create space between its members and non-members while carrying food and drinks to the forest. It also deployed space and spatiality to create space between the residence of its leader and members, to create space between residences of its members and non-members, to create space between groups of dancers, and between individual dancers during ceremonies, to create space between groups and between individuals in each group during marriage and naming ceremonies, as well as during funeral rites. Moreover, Ayirikpu cult deployed space and spatiality to create space between the point where it performs ritual and danger zone. Space and spatiality which members of the public and Ayirikpu cult deployed to create space between their domiciles and environs and between different groups during social gathering or ceremonies are close

space of personal distance, close space of social distance, space arrangement, public close distance, public close space and public far space.

### **Conclusion**

The study reveals that space and spatiality are deployed by members of the public in Didan community to create spaces between their domiciles and environs. Ayirikpu cult deployed space and spatiality to create space between their members and non- members while carrying food and drinks to forest; they also employed space and spatiality to create space between residence of its leader and members, to create space between different groups and between individuals in each group while performing rituals or ceremonies. The study concludes that different aspects of space and spatiality deployed to create spaces between people's domiciles and environs explains why the community is well structured

### **References**

- Fox, C, Manning, E, Murphy, M, Urban, R & Marwick. K.C, (2003). Space In Longman Dictionary of Contemporary English: person Education.
- Graines, E. (2006). Communication and semiotics of space. *Journal of creative communication*, 8(2), 174-181 <https://doi.org/10.1177/0973258606000>.
- Hollink, L, Wielinga, B.J & Schrelber, G. (2004). Adding special semantics to image annotations. [fill:///C:/Users/YAKUBU/Downloads/download-2.pdf](file:///C:/Users/YAKUBU/Downloads/download-2.pdf)
- Kobayashi, A. (2017). Spatiality. <https://doi.org/10.1002/9781118786352.wbieg1167>
- Mcgregor, J. (2004). Spatiality and the place of material in schools, pedagogy, culture and society. <https://doi.org/10.1080/14681360>
- Remm, T. (2011). Understanding the city through semiotic spatiality. *Sign system studies*, 39(2/4), 1-21. <https://doi.org/10.12697/SSS.2011.39-2-4.06>
- Schulze, B.A. (2014). Spatiality analysis. In Michalos, A.C. (Ed). *Encyclopedia of quality of life and well-being research* (pp 6259-6261). Springer, Dordrecht. <https://doi.org/10.1007/978-94-007-0753-5-2818>
- Space (n.d.). In *Britannica Dictionary*. Retrieved from <https://www.britannica.com/dictionary>

Space (n.d.). In Oxford Learner's Dictionary. Retrieved from <https://www.oxfordlearnersdictionaries.com/definition/english/space-1>

Space (n.d.). In Cambridge Dictionary. Retrieved from <https://dictionary.cambridge.org/dictionary/english/space>

Spatial (n.d.). In Cambridge Dictionary (3<sup>rd</sup> ed). Retrieved from <https://dictionary.cambridge.org/dictionary/english/spatial>

Spatial (n.d.). In vocabulary.com dictionary. Retrieved from <https://www.vocabulary.com/dictionary/spatial>

Spatial concepts (n.d). Retrieved from [https://spetacokids.com/spatial concepts](https://spetacokids.com/spatial-concepts)

Sultana, C. (n.d.). Location, space and time in geography. [www.mkc.ac.in/pdf/study-material/geography/2ndsem/1512624915conceptoflocation.pdf](http://www.mkc.ac.in/pdf/study-material/geography/2ndsem/1512624915conceptoflocation.pdf)

Tuan, Y. (2017). Space vs place (Revised edition). Geography ruhosting. [nl/geography/index.php?title=space-vs-place&oldid=5653](http://nl.geography/index.php?title=space-vs-place&oldid=5653)

## **Appendix**

### Appendix: Names of interviewees

1. Bwanu Endajo
2. Endagwa Janu
3. Fachanu Chuseh
4. Fadwa Boma
5. Museh Echati
6. Bwaseh Tidwa





## THE IMPACTS OF WOMEN ASSOCIATION IN PROVIDING SANITATION FACILITIES ON COMMUNITY DEVELOPMENT IN CROSS RIVER STATE

<sup>1</sup>Bassey Ekpenyong Anam, <sup>2</sup>Virginia Emmanuel Ironbar, <sup>3</sup>Otu Offiong Duke  
& <sup>4</sup>Esther Esien-Cobham Uzoh

<sup>1</sup>Institute of Public Policy & Administration, University of Calabar, Calabar

<sup>2</sup>Department of Continuing Education and Development Studies,  
University of Calabar, Calabar

<sup>3</sup>Department of Public Administration, University of Calabar

<sup>4</sup>Department of Social Work, University of Calabar

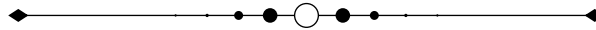

### **Abstract**

*For decades, women's associations have been major participants in community development. This study examines the impacts of women's associations in providing sanitation facilities on community development in Cross River State. The Ex-post facto research design was used in the study. 140 respondents were used for the study. A simple percentage statistical tool was used for the analysis of data. The results show that women's associations play a significant role in providing sanitation facilities in rural communities of Cross River State.*

**Keywords:** *Women's association, rural development, sanitation facilities*

---

### **Introduction**

Alamin (2007) observed that “in most African traditional societies, women have been regarded as fragile and should be subordinate to the man, but they can play a vital role for the betterment of the society”. This fragile nature has proved her domineering influence on many occasions in the history of mankind. Across the country, women have created innovative and comprehensive socio-economic activities to meet the needs of their communities. Women have established themselves as leaders in the community development process and have acquired the skills that have positively changed their communities. This is significant for the women's associations in Calabar South Local Government Area, of Cross River State. Their structural formation, objectives, and economic

activities have placed them as builders of social capital, otherwise referred to as income-generating activities, and providers of basic economic activities in their homes, communities, and the state (Kalu, 2014). Also, these women's associations mobilize other members of the community, especially the youth, provide sanitation services, provide water facilities, and maintain important relationships and networks in their communities which leads to social solidarity and peaceful coexistence.

For lack of adequate economic resources and financial abilities, to take on and complete specific projects, women play complementary and supportive roles to their male counterparts. While implementing specific projects like town halls, health centers, sanitation, water facilities, etc, women help in carrying sand, fetching water, and other supporting roles. This has helped in achieving the objectives of community development (Chinendu, 2008). Their funds are often derived from income-generating activities such as agriculture and voluntary contributions. For effective development to occur, their contributions need not be disputed.

This notwithstanding, Kalu (2014) disclosed that these women associations women are often faced with challenges of racial, cultural, economic, and political barriers that exist in the community development process. Women lack the training and the means to bloom, and this is needed for advancing the position of women: strengthening their capacities and skills and expanding the opportunities for women to more fully develop their roles (Kerlinger, 1986). Most women live and work under deteriorating material conditions due to economic and social decline and conflicts (Alufohai and Ahmadu, 2005). There are developmental costs of ignoring women and denying them access to key resources and the severe economic constraints tend to undercut it (Nawaz, 2009). The continuing poverty and deprivation in the country, declining terms of trade, and the burden of external debt create an unfavourable environment for development. Of the limited resources available, little is directly allocated to women.

However, Rahman and Naoroze (2007) maintained that “in many cases overcoming those barriers becomes their motivation”. While their comprehensive approach has influenced the evolution of the community development field, women's contributions have been neither widely acknowledged nor explicitly credited. Studies that examine the role of women associations in development provide deeper insights into women's thinking about community development, the barriers they perceive to women's leadership, and the kind of efforts that should be made to facilitate and promote their status and roles in the field. Notwithstanding these challenges, women associations in Calabar South local government area of Cross River State and other parts of the world have shown ways they support the process of their community development. They have proven to be effective entry points for initiating economic activities or development projects in the community that are beneficiary to all members of the community. This paper will examine the contribution of women's associations in community development, using the Calabar South Local Government Area, of Cross River State.

### **Statement of the problem**

In Cross River State, as it may be observed elsewhere, it is believed that men's work is outside the home and women's work is inside the home. Gender inequality contributes to the low contribution of women to community development. Women are mostly in their domestic sphere and not in certain matters expected to be in the men's domain. Also, the economic and domestic workloads deprived women of the time to effectively function in their associations. Of course, this limits the objectives and operations of women's associations in the Calabar South local government area and further affects the extent to which they contribute meaningfully to community development in the state at large.

Certain laws and customs also impede the association's access to economic opportunities, credit, productive inputs, employment, education, information, and politics. Women associations in the Calabar South local government area lack funds for the day-to-day running of their organisational goals and this problem led to the abandonment of some projects. The group finds. As a result, they contribute little to the community development process. Income-generating activities are slowed and the contribution of women's associations in sanitation and the development of small and medium-scale enterprises are not significant. With these problems, women's associations in Calabar South local government area have not been able to contribute meaningfully to the development of their community. This concern forms the basis for this study. This study examines the impacts of women's associations in providing sanitation facilities on community development in Cross River State.

### **Research questions**

Does the provision of sanitation and water facilities by women's associations contribute to community development?

### **Literature review**

#### **Women's association in community development in Nigeria**

According to Kalu (2006), a woman's organisation is an association of women who have come together for their interest and that of their community, Women organisation can be found in different levels or areas across the world. It can be found in the villages, towns, or at the state and national levels. According to Bell (1970), we have uncountable women organisation; local, national, and international based, for example, we have Women Community Development Organisation (WCDO), Women Community Development (WICD), Black Christian Women's Organisation (BCWO) Women-led Community Development Organisations (WLCDO), Catholic Women Organisation (CWO) and many more. All these groups have the common aim of contributing to the development of their communities through their numerous activities (Clayton, 1994). Through the infrastructure, comprising regional support organisations, networks, women's centers, and local groups engage in a diverse range of valuable contributions to promoting equality, social and economic inclusion, peacebuilding, and the development of their communities.

For the past three decades, women have been major participants in community organisations (Dalton, 1998). In the 1960s and 70s, community women advocated for control of local services and neighbourhood preservation (Alufohai and Ahmadu 2005). In the 1980s, they were among the few forces pursuing neighbourhood preservation in the face of uncontrolled downtown growth. Religious congregations, particularly those formed by women have been an integral part of community development during the same period and their connection has been a factor in attracting talented women to the field (Ditcher, 1992). Hundreds of community development organisation began life in the church basement while national councils and local congregations have supplied millions of dollars, staff, services, and ongoing support. This spiritual dimension is usually among current social reform initiatives. The faith-based legacy, stressing a holistic view of community revitalizing, is compatible with the approach many women embrace. The willingness of faith-based grassroots groups to accept women as leaders offer valuable providing ground, and many women have gone to apply those lessons, and the resources of their organisation to strengthen their communities (Drasgupta, 1990).

For the past 20 years, organisation with strong women's leadership have resisted the narrow definition of community development as consideration of affordable housing and economic development agency for international development (1974). These organisations have always defined community development issues as these responding directly to the needs of women, children, and families, even in the absence of funding for such broader concerns. Foundations and governments have only recently begun to recognize the wisdom of the approach (Drezer and Sen, 1990). The current emphasis in public policy initiatives and foundations funding on comprehensive community initiatives (CCIS) affirms the long-term commitment of many women-led organisations and the role women play as catalysts for social changes. Women build social capital through leadership, community participation, and networking. There is a continuum of women's leadership styles ranging from an inclusive, collective, "feminist" model to a more traditional hierarchical mode. As in previous gender-specific research in other fields, women community development leaders describe themselves as open, consultative, and supportive of staff both in the community and within their organisation they are committed to participation process and internal democracy, and many women reported a preference for consensus building and this approach to seeking peaceful resolution of issue contributes to a participating style of leadership (Friedman, 1992).

Women also focused on social change as a goal. The desire to create social change is at the core of much of women's community development work. Women's vision of change broadly aims to change people's lives, deepen their investment in their neighbourhoods, and increase their access to resources to improve the quality of life in the community. Friedman (1992) many women measure organisational success in terms of the health of their communities and empowerment of residents in addition to more traditional, quantifiable measures. Women have created a pattern of activities designed to create an environment where changes can happen in communities. Not every women-led organisation offers a range

of comprehensive services, but they are all characterized by their degree of awareness of the interconnection between personal, social, and economic issues affecting community residents.

Women's organisation by their very role and contribution first and foremost to community development by providing life-changing opportunities to women across the full range of ethnic and religious backgrounds ages sexual orientations, abilities, and educational levels. Meanwhile, according to the task force on resourcing the voluntary and community sector, community development can be defined as “empowering individuals and groups to take issues that affect their lives and the communities in which they live (Inglehart, 1997). The task force acknowledges that to do this, people need to work together and “in partnership with other groups and statutory agencies”. The impact of Christian women's organisations goes much further than the immediate benefit to their direct service users. For example, Dalton (1998) states that women's centers are invariably at the heart of community development initiatives within the communities such as economic and physical regeneration projects as well as their particular on “a wider range of advisory bodies and partnership” (Dalton, 1998).

Women's associations have gathered themselves into strong organisation with different aims and objectives. They have contributed immensely towards community development. In another development, women's associations have emphasis so much in development programmes like road construction and maintenance, building of classroom blocks, church projects, civic, etc, with or without government involvement. They are involved in an innovative project to promote the living conditions of individuals in the communities. They set up training centers in the community for male and female drop-outs and those who cannot do agricultural work are allowed to become self-dependent. They teach woodwork, carpentry, tailoring, embroiling, hairdressing, electrical work, and mechanics (Jackman, 1987).

The important but other invisible contribution of women's groups in the economic and social development of their communities and the plight of low-income women has been well acknowledged and publicized by the United Nations Decade for Women (1976-1985). This shows that the contribution of women's associations in community development projects such as housing, which provides women with marketable skills and income but also in a wilder context embraces health, childcare, better household management, and control of the environment combined with providing an opportunity for women to organize and negotiate for better control of their lives and develop their potential for community leadership (Dalton, 1998).

In the parts, it was evident that women's activities were inhibited by formal organisations which tended to be dominated by men but the emergency of the involvement of women's associations in community-based information production and childcare, gives women associations, the opportunity to associate with each other and articulate their concerns

develop new skills and finally manage activities. Initially, it could be safely assumed that the involvement of women's associations in community participation is a national and automatic process with the result of achieving self-reliance of all the community members. The women's association contributes to the development of their communities by raising funds for the church and other community development projects. They believe that they are the financial backbone of the church. The money that they have raised has been used to finance revival meetings, build churches, pay for salaries to teachers in church-owned schools, finish the church and the ministries' house, buy food for church functions, and help the poor, the sick, and the bereaved in the community. In other words, the functional leadership of the church was de facto in the hands of the Christian women's organisations. Khan and Rahaman (2007) maintained that in their bid to contribute to the development of their community women's associations embark on praying for peace in times of war. They embarked on praying and fasting, they became prayer warriors in the fight against sickness and death in their families and the community. They referred to the fighting groups as "our children" hence the intensive prayers for peace.

During the apartheid era, they prayed about political violence and after two months, the violence stopped, because their prayer for peace was answered. Women leaders from various church organisations gathered on several occasions to pray for peace especially when the elections were approaching. They prayed for peaceful elections, and they believed that god answered their prayers. And since there might not be any meaningful development during the time of war and political unrest, the women's association through their prayers for peace, has contributed immensely to the development of their communities.

Little (1964) observes that before the development of the formal social welfare system in West Africa, women's voluntary organisation took the major responsibility of catering to the needs of the sick, the poor, and the disabled in the society focusing on Nigeria. Little reported that women's groups have always played an important role in community development through village associations and councils. Egboh (1987) reported that various women's associations such as the Umuada, and the married wife association of various village groups in the Eastern part of the country, undertook various aspects of community development. Egboh reported that the women organized various activities for the welfare of both the members of their natal and marital home and also organized peaceful relations among warring communities and in such a way-maintained peace. He pointed out that those women equally organized activities that could enhance their welfare such as dancing groups etc, where they could raise some resources for development projects that would be beneficial to all.

Robinson (2006) observed that women's contribution to community development has improved in recent years and the number has continued to improve. He pointed out that women, considering their passionate nature, are in the best position to effectively carry out community development initiatives. Robinson categorically stated that in areas where men have dialed to deliver the goods to the people in the community, women have succeeded,



especially in providing succor to the motherless children as well as the disabled or physically challenged citizens in the society. This research therefore acknowledges the activities and contributions of women's association to the development of their communities.

### **Women's associations and the provision of sanitation and water facilities**

Sanitation is defined as access to a convened-pit latrine in which the feces are kept isolated from the environment. Sanitation also includes safe disposal of children's feces proper hand washing practices before eating and after defecation, and hand washing after cleaning the feces of a child (BBS and UNICEF, 2009). Like in many other developing countries, sanitation facilities are still a major challenge in Nigeria. The low sanitation coverage (43% of households) in Nigeria poses a serious public health concern. Among the 43%, only 13% use sanitary latrines, and another 30% use homemade pit latrines (World Bank, 2010). It is estimated that 71% of rural households and 40% of urban households practice open defecation or use unhygienic latrines. The conditions are worse in rural areas; ignorance, poverty, the traditional practice of open defecation, the use of hanging latrines (flimsy structures built on stilts over rivers and streams), and lack of knowledge about handwriting pose a serious threat to hygiene and the environment. In addition, LGD (2005) reported that 42% of households do not have latrines due to a lack of financial resources, lack of awareness, and so on.

Inadequate access to safe water and sanitation leads to various health problems for people. Water and vector-borne diseases like diarrhea, dysentery, typhoid, worm infestation, polio, malaria, hepatitis, and other parasitic infections are too common in Nigeria and cause numerous deaths. In rural areas, about 69,000 children below the age of five die of diarrhea every year because of inadequate sanitation (HO, 2009), which is easily preventable by improving sanitation and creating awareness to practice hygiene such as simple hand washing, with soap. GoB, UNICEF and ICDDR, B (2008) reported that less than 1% of Bangladeshis wash their hands with soap before they eat and fewer than 17% wash their hands with soap or ash after defecation. According to WHO and UNICEF (2006), about 22% of the population of the country is still exposed to drinking water which does not comply with WHO standards. On the other hand, surface water is usually polluted and requires treatment. Many parts of the country have arsenic contamination in the groundwater (UNICEF, 2006; UNDP, 2000). Still, the government claims that about 90% of people have access to safe water (BBS 2008).

Reiterating the importance of women in sanitation, Khan and Rahaman (2007) say the government through several non-government organisations, bilateral development partners, and the United Nations jointly declared their commitment to ensuring the right to safe water in rural communities in Nigeria by training rural women on the strategies for effective environmental sanitation and other health-related activities. To cover safe drinking water and sanitation nationwide, the government of Nigeria's NGOs, development partners, civil society, media, and private sector institutions are currently pursuing an integrated approach by promoting a package of increased tube well installation, improved sanitary

practices like the promotion of home-made pit and water seal latrines combined with health education so that the spread of waterborne and other contagious diseases can be reduced or even prevented. Women play a very important role in the achievement of this objective.

### **Challenges of women's association contributions to community development**

The women's associations face various barriers in their bid to contribute to the development of their communities. Khan and Rahaman (2007) identify some of these challenges to include;

- i. Lack of funds: Women's associations lack funds for day to day running of their organisational goals. This problem leads to the abandonment of some projects. Because of a lack of funds, local government and most communities are not able to undertake or complete undertaken projects. As a result of the lack of funds, women's associations have not been able to contribute to the extent they should have contributed to the development of their community. The group finds it difficult to raise funds for a meaningful project, because of this, they contribute little to the community development process.
- ii. Embezzlement of funds: This is one of the problems facing various kinds of organizations, and the case of women's associations is not an exception. This problem is more disheartening and discouraging people's morale is always low when the first contribution is not accounted for, due to mismanagement of funds. This disrupts the interest of people. Some projects have been suspended because of public embezzlement of funds. Because when the first attempt is not well accounted for, people tend to withdraw or contribute to such development or project.
- iii. Inflexible work schedules: This has posed a problem to a good number of women's associations. This is because, women who are primary caregivers find it difficult to take positions such as executive director or community organizer, which often require extensive attendance at night meetings which is difficult for women caring for young children or elderly parents. In a situation where they must attend a conference out of town, they must schedule their time around their families, and this is usually not easy for them and in turn, poses problems and barriers to their contributions to community development.
- iv. Illiteracy: The inability of many women to pursue education has caused a lot of problems in their contribution to the development of the rural community. Most of the citizen in rural areas is illiterates. Cultural traits and skills persist because of illiteracy. it contributes to inadequate planning for development projects. Many women have overcome this barrier have done so by pursuing training or degrees to fill specific gaps in skills or by obtaining credentials but for many others, the lack of conventional education is a major barrier. The reason for this illiteracy is the time they devote to raising families and the lack of good, affordable daycare which leads to

their inability to pursue education. As education is one of the key factors to development, and some women lack it, it poses a problem because these women will contribute little or nothing to the development of their communities.

- v. Limited access to the political network: Women's associations do not feel they have adequate access to political leaders' corporate executives, and other powerful groups that generally consist of men. Women's access to power brokers does, however, vary from city to city and region to region. Many women leaders testified that they did not have control over the money that they had raised. The male church leaders do control the money. This is because of limited access to political networks or power in the church. This contributed to the problem encountered by the women's association in community development.
- vi. Disunity: As well as known, there cannot be any meaningful development in the present of the disunity. No wonder the saying that "two cannot move, except they agreed". The issue of disunity is a problem that hinders the contribution of the women Christian groups to the community development process. This is because, where there is disunity, the period of gathering may be defeated. People have different opinions and read meanings into any suggestion made by the other. Such people may discuss for hours without achieving a point. Women's association, in times of disunity, cannot contribute immensely to community development.
- vii. Land disputes: Women's associations at times experience land disputes as barriers to developmental projects. This might be a refusal of the landowners to give out or sell the land for the project at hand. If the land in question is located at a very good site for the project, the dispute might hinder the progress of such a project and might lead to the delay or abandonment of such a project.
- viii. Low level of community participation: This is another issue women association in Mbaise, cannot do it all alone. This is because for any meaningful development to occur, all hands must be on deck. Many community women cited issues related to personal, class, and cultural barriers to their participation in community development. They lack economic security, such as lack of childcare, the lack of freedom to leave domestic responsibilities, and feelings of powerlessness. Family and other personal issues have posed significant obstacles to their contributions and involvement in the community development process.

## **Methodology**

### **Research design**

The Ex-post facto research design will be used in this study. According to Kerlinger (1986), Ex-post facto is a systematic empirical inquiry in which the scientist does not have direct control of independent variables because they are inherently not manipulable. In effect, there is no manipulation of the independent variables used in this study. Denga and Ali

(1983) observed that an Ex-post facto research design is a situation where causes are studied after variables have presumably exerted their effects on other variables before the researcher got there.

The variables in this study are presumed to have already impacted the communities in Calabar South Local government area of Cross River state before the time of this research. Therefore, there won't be manipulation of the variables by the researcher. The researcher will attempt to describe the effects of such variables as found in existence during the study. The design is assumed to be appropriate because the study is concerned with examining the impact of women's associations in community development in Calabar South local government area of Cross River state.

### **Sample size**

The sample size of this study will be one hundred and forty (140). Twenty (20) persons will be selected from each of the 7 women associations and used as the sample size of the study.

### **Sampling technique**

Purposive sampling will be used for this research. The researcher will personally visit the villages used for the study. The research instrument will be randomly administered to the identified members of the women's associations selected for the study. However, it is important to note that there will be a pre-visit and consultation with women's association leaders. The exercise will take place on Sunday evenings. This is because the associations usually meet on Sundays. The categorization of respondents will be based on membership for at least 5 years. After identifying these in their category, the researcher will do a ballot using papers. Purposively, the researcher will write out "Yes" and "No" into 20 places each, shack them well in a bag, and ask members to pick from the basket. The twenty people who will pick "Yes" in the distribution will be used for the study. By this method, the researcher will eliminate all forms of bias.

### **Sources of data**

Data will be drawn from Primary and Secondary sources. Primary data involve information obtained from field surveys by the researcher, otherwise known as first-hand information, while the secondary data will be derived from already available information from other authors, state government and local government publications, texts, journals, thesis, etc.

### **Method of data analysis**

Data collected will be properly checked to make sure all items were responded to. Thereafter, they will be edited, coded, and analyzed using appropriate statistical methods. Simple percentages will be used for data analysis.

### **Discussion**

This section presents data obtained from the research instruments and their analysis. In this study, one major research question is raised. Does the provision of sanitation and water facilities by women's associations contribute to community development?

### Research question

Does the provision of sanitation and water facilities by women's associations contribute to community development?

**Table 1:** Showing the distribution of respondents on the research question

Responses	No/Respondents	Percentage (%)
Yes	84	60
No	76	40
<b>Total</b>	<b>140</b>	<b>100.00</b>

Source: Researcher's field work, 2022

The result in Table 1 shows that 84 respondents said Yes, while 76 respondents said No. Since the number of respondents that said Yes is more than No, the study reveals that the provision of sanitation and water facilities by women's associations contributes to community development.

### Conclusion

The study reveals rural women play pivotal roles in almost every aspect of our society. They have made important contributions in creating access to human, natural, financial, physical, and social capital for making their livelihood sustainable. All phases of agricultural activities from seed sowing to harvesting and processing of crops are ultimately done by rural women. Women participate in both farming and non-farming activities directly or indirectly with men. The small farmland and homestead area is being used mostly by women. The study therefore concludes that, for there to be meaningful rural and community development, women should be effectively empowered.

Based on the results obtained, the study recommends the need for sustained efforts towards rural sanitation and the provision of potable water in communities in Cross River State. Moreso, rural/community women should be trained and retrained through literacy programmes. This will enhance their socio-economic status and more contributions to community development.

### References

- Afrin, S; Islam, N; and Ahmed, S. U. (2008) *A Multivariate Model of micro credit and rural women entrepreneurship development in Bangladesh*. International Journal of Business and Management, 3(8):169-185.
- Ahmad, M. (1997) *Education Watch Report 2003/4: Quality with Equity: The primary education agenda*. Dhaka: Campaign for popular education 207.
- Alamin, S. (2007) *Role of women in maintaining sustainable livelihoods of Char Landers in selected areas of Jamalpur district*. Ph.D Thesis Department of Agricultural Extension Education Bangladesh.

- Alufohai, G. O. and Ahmadu, J. (2005) Queue management by Nigerian agricultural cooperative and rural development bank (NACRDB) in farm credit delivery: The case of Benin Branch, Edo State, Nigeria. Proceedings of the 39th.
- BBS and UNICEF (2009) Progotir Pothey: preliminary report. Dhaka: Bangladesh Bureau of Statistics and UNICEF 2010.
- Bebbington, A. (1999) *Capitals and capabilities: A framework for analyzing peasant viability, rural livelihoods and poverty*, world development 27 (120: 2012-44).
- Bell, D. (1970) *The coming of postindustrial society: A venture of social forecasting*. New York: Basic Books.
- Brown, A. (1994) *Group work 3rd edition* Great Yarmouth: Ashgate publishing.
- CBN (2005). National Economic Report, Vol. 89.
- Chowdhury, M. J. A. (2007). Does participation in the Microcredit programmes increase the consumption of participating households? The case of the Grameen Bank in Bangladesh. Center for Microfinance and Development (CDM) working paper 03, University of Dhaka, Bangladesh, 1-16.
- Clayton, A. (1994) *Governance democracy and conditionality: What roles for NGOs?* Oxford: INTRAC.
- Dalton, R. (1998) "Citizens politics; Public opinion and political parties in Advanced Western democracies". 2nd ed. Chatham, N. J. Chatham House.
- Denga, D. I. and Ali, B. (1983) *Understanding group behavior*. Ibadan: University press.
- Ditcher, T. (1992) *Demystifying popular participation*. Bhatnagar and Williams (eds). In people's participation in development projects. Pg. 6.
- Dasgupta, P. (1990) Well-being and the extent of its realization in poor countries. *Economic journal Cambridge*, Vol. 100 No. 400.
- Dreze, J. and Sen, A. (1990) *Hunger and public action*. London: Oxford Press.
- Fakir, S. K. (2008) *Women empowerment through participation in income generating activities of sabalamby Unnayan Samity*. Ph.D Thesis Department of Agricultural Extension Education Bangladesh Agricultural University, Mymensingh.



- Friedman, J. (1992) *Empowerment: The politics of alternative development*. Oxford: Blackwell.
- GoB, UNICEF, and ICDDRDB (2008) *Baseline survey results in the final report, Health impact study: Sanitation, Hygiene and water supply in Bangladesh*.
- Gupta, M. V. (1992) *Aquaculture for small farmers: technical development and dissemination strategy*. Small farmer vulnerability. ICLARM contribution No. 845. Manila: ICLARM. 120-127.
- Haque, M. S. and Yamao, M. (2008) *Can micro-credit alleviate rural poverty? A case study of Bangladesh*. *World academy of science, engineering, and technology*, 46: 648-656.
- Harper, M. (2003) *Microfinance evolution, achievement, and challenges*. 25-26.
- Hoque, M. and Itohara, Y. (2008) *Participation and decision-making role of rural women in economic activities: A comparative study for members and nonmembers of the micro-credit organisations in Bangladesh*, *Journal of social sciences* 4(3): 229-236.
- Hossain, K. S. Rahman, M. (1999) *Role of Grameen Bank in entrepreneurship development: A study on some selected entrepreneurs Islamic University (Part C)*, 2:7-13.
- Inglehart, R. (1997) *Modernization and post-modernization*. Princeton: N. J. Princeton University Press.
- Islam, M. S. and Aktaruzaman, M. (2001) *Teg problems of rural women entrepreneurs in Bangladesh: A case study of Ijenaidah District Islamic University (Part C)* (491) 1-19.
- Jackman, R. (1987) *Political institutions and voter turnout in industrialized democracies*. *American Political Science Review*. 81-405-423.
- Kalu, V. B. (2014) *Cooperative movements: A way out of poverty*. Longman: Macmillan publishers pp. 9-10.
- Kerlinger, G. (1986) *Labour migration and rural transformation in post-colonial Swaziland*. *Journal contemporary African studies*, 13 (2), 206-207.
- Khan, A. and Rahaman, A. (2007) *Impact of microfinance on living standards empowerment, and poverty alleviation of the poor people: A case study on microfinance in the Chittagong District of Bangladesh*. Master Thesis Fall 2007, Umea School of Business (USBE), Department of Business Administration.

- Momen, M. N, and Begun, M. (2006) Impact of microcredit programme development in Bangladesh: A case study of BRAC. *Asian journal of information technology*, 5(11) 1269-1283.
- Nawaz, F. (2009) Critical factors of women entrepreneurship development in rural Bangladesh. *Bangladesh development research working paper series 5 (BDRWPS)* 1-16. 222.
- Rahman, M. H. and Naoroze, K. (2007) Women empowerment through participation in Aquaculture: Experience of a large scale technology demonstration project in Bangladesh. *Journal of social science* 3(4):164-171.
- Sherif, M. (1984) *Attitude change and attitude formation*. London: Oregon Press.
- UNDP (1997) *Promoting sustainable livelihoods: A briefing note submitted to the executive committee, June 4, 1997 (mineo)*.
- UNICEF (2006) *Environmental sanitation hygiene and water supply project in rural areas (ESHQWRA)*. Dhaka UNICEF.
- UNIFEM (1998) *Gender considerations in sectoral planning for pacific island planners in Agriculture, fisheries and forestry*, UNIFEM Pacific regional office, Suva, December.
- Warner, K. (2000) *Forestry and sustainable livelihoods: What part can forest, and forestry play in reducing poverty?* *Unasylva*, 202, Vol. 51, 2000, pg. 3-12.
- WHO (2009) *Macroeconomics and health: investing in Health for Economic Development. Report of the commission on macroeconomics and health*. Geneva.
- World Bank (2010) *Bangladesh GD data and country report: Global finance*. Available at [www.gfmag.com/archives/April2011](http://www.gfmag.com/archives/April2011)(Searched date: 20 July 2011).



## SWEM AS AN AGENT OF JUSTICE IN TIV PHILOSOPHY

<sup>1</sup>Tughhembra Terfa Nicholas & <sup>2</sup>Ogaba, Solomon Isenyo

<sup>1&2</sup>Department of Philosophy

Federal University Wukari, Taraba State-Nigeria

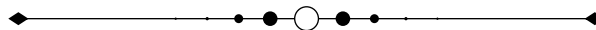

### *Abstract*

*Since time immemorial in the history of man, efforts have been made to order the steps of mankind in a manner that society will enjoy peace, growth and stability. In Tiv society, Swem was inaugurated an agent of justice. Due to its rapid result, the Tiv thought it wise to use it to end dishonesty and evil. Thus, the study examined Swem as an agent of justice in Tiv society today. Qualitative research design was employed for this study. The historical method was used to trace the origin of Swem. The expository method was used to explain Tiv thought system as well as the basis of Tiv conception of Swem while the analytical method was adopted to examine the place of Swem in the enforcement of justice and cohesion in Tiv society. The effects of modernity on the use of Swem in Tiv society today. The researcher found out that Tiv society has lost her order in most communities as a result of the relegation of Swem to the background. This has led to injustice, untimely death, wickedness, greed, irresponsibility, envy and disunity. The paper therefore concluded that there is need to reintroduce Swem in the affairs of mankind in order to return peace, order and development in human society. This has become imperative to save truth and fairness from the modern law courts where justice is denied and, even bought.*

**Keywords:** *Agent, Justice and Philosophy*

### **Background to the Study**

According to Tiv worldview, the universe was created by the Almighty God-*Aondo*, the Supreme Being. *Aondo* has made available to man, or, spirit beings as intermediaries that are meant to assist him in his various needs. It is with the help of the spirit beings that the Tiv enforce the will of God in their society. They use *tsav*, witchcraft, to control the supernatural for the good of the society. According to Iyo (1990:126), *tsav* was the most powerful instrument in the hands of the elders. To buttress further, Dzurgba (2007:180) acknowledged that with *tsav*, the Tiv have *Swem*, a mystical force whose power lies in the community to protect the innocent, identify the unjust and punish them by death. The use of *Swem* became necessary given that the use of human sacrifice to "repair the land" by communities degenerated to the

level that some witches and wizards were killing for self-aggrandizement. Accordingly, Rubingh (1969:94) contended that through the years the malevolent side of *tsav* came to the fore and the possessors of *tsav* as a class became known as *mbatsav* and were greatly feared for the terror they brought through sorcery, causing disease and death.

Today, with the influence of Christianity and modernity, most 'civilized' Tiv communities have relegated this traditional value that picture the Tiv understanding of justice to the background. *Swem*, is no longer used in most Tiv communities to enforce justice. Even where it seems to be in practice, there are cases of abuses, where the elders 'falsely' involve it on issues that are unjust. At the same time, because of belief in Christianity, many consider swearing on *Swem* as ungodly and it is being replaced by the Bible in matters of oath taking. However, given that the Bible does not have immediate consequences like *Swem* and it seems difficult to use to bring out the truth in critical situations, many today prefer it. This has led to the collapse of the mechanism for enforcing justice in Tiv society. In this work, we seek to establish the challenges in the use of *Swem* as an agent of justice in Tiv society today, noting cases of unjust abuse of the practice. We shall also re-state the fact that the relegation of this traditional practice to the background has given room to corruption and wickedness as well as sorcery to thrive in Tiv society. Revival of this great agent of justice and its true practice will meaningfully contribute to recovery of justice system in Tiv Society and enhance law and order.

### **Tiv Thought System**

Philosophy is an all-embracing subject based on the peculiar nature and scope of the subject. At the beginning, philosophy was an attempt at unraveling the mystery of all that is in the universe and finding answers to fundamental questions. This makes philosophy impossible to define and shows clearly that its definition is better imagined than said. With this, it is referred to as the mother of all sciences.

The insurmountable disagreement by philosophers on the definition, nature, scope and method of philosophy has led to many philosophies as there are many philosophers. This diversity has been accommodated and today philosophy is an unbounded enterprise and unrestricted to a definite person, age and race. Today, we have Indian philosophy, Buddhist philosophy, American Philosophy, Islamic philosophy, African philosophy and Catholic philosophy etc. In Africa today, we have Bantu philosophy, Yoruba philosophy, Igbo philosophy and Tiv philosophy etc. all these indicate that not anything can be taken as philosophy. Every school of thought referred to as philosophy must have to do with the search for meaning in human existence, truth, certainty, understanding of transcendental reality and how the spiritual affect the physical realm of the universe, rational explanation of reality and logical analysis of language. With this scope, philosophy is said to be meaningful to humanity.

The Tiv word for philosophy is *ieren*, meaning the act of doing something; the way a thing is done; the doing of a thing. According to Anshi (2004), "it connotes the understanding of the facts of a thing." By definition, Tiv *ieren*, philosophy is "... the system of thought underlying the behavior of the Tiv people" (xii). It also means the way the Tiv people think, talk and act. It

is the Tiv understanding of reality, truth, the metaphysical realm, human relationship and the universe at large. In other words, Tiv philosophy:

*...can be defined as a way, method and systemic way of doing things and or understanding events reflecting both the mental and the experiential capabilities of the person and or the group... whatever activity we are engaged in, whether at the level of critical thinking, analysis, speculation and sense experience in all ieren. Tiv ieren is therefore, the fundamental basis of understanding the Tiv people in their metaphysical, epistemological, aesthetical, logical, political behaviors. Tiv ieren eschews all undue reliance on transcendentalism being without the accruing benefit for man (xii).*

The philosophy of a people is the way they perceive reality, in thought and action. It is basically concerned with right living and this is the concern of Tiv philosophy. Tiv philosophy deals with the good and bad, right and wrong behavior of the Tiv people, with the aim of projecting the good and emphasizing it as acceptable *modus operandi* for the good of humanity.

#### **Gbaaondo: The Basis of Tiv Conception of Swem**

According to Akwaki (2006), *gbaaondo* is derived from two Tiv words, *gba* and *aondo*, meaning fall, or create and God respectively. *Gbaaondo* means God's creation or what is made by God. The Tiv teach that the universe was made by a just God. This just God made gods or spirits to be the intermediaries between him and mankind. The spirits made by God were meant to help man in all his needs. The Tiv before used the spirits to enforce justice. For they believe, the spirits are made by God and help in carrying out God's will on earth. As shown above, justice did not originate from man but from God himself. The Tiv believe God is just and has made the spirits, *ajov*, to mediate between man and him to sustain justice in the society. It is these actors, *ajov*, that enforce the will of God through the use of *Swem*.

#### **Definition of Swem**

*Swem* means a place, the most important and central Tiv Akombo (Moti & Wegh, 2008). *Swem* is a name the Tiv gave to the hills on which they lived when they were migrating from central Africa. *Swem* is a mystical force that protects an individuals' right to life, to his children's lives and welfare. It protects the innocent, identify and punish those that violates religious and social justice. Even if the evil is perpetrated under the auspices of *mbatsav* or *azov*, *Swem* deals with it very well. According to Dzurgba (2007) "*Swem* '...swells the stomach of the guilty person and kills him, but protects the innocent. Thus, it is the last resort in seeking for justice." *Swem* therefore is a symbol of truth '*mimi*', justification '*chia*', universal justice, and enforcing power, the symbol of totality of Tiv society and culture in all its sacredness.

#### **The Origin of Swem**

The origin of *Swem* is ambiguous but many Tiv people believe when their father died, he was buried at *Swem*, the foot of one of the mountains. Before the burial his children cut off his head and carried it along their journey. When they discover it was going bad, they burnt it and carried the ashes. It is these ashes that are used in preparing *Swem* (Moti & Wegh, 2001).

Another legend has it that there was a Tiv man called Ikaragbe from Nongov in Northern Tiv society who practiced *tsav* and used his entire family for sacrifice as payment for the debt of the other peoples' flesh that he ate. When he discovered that his community was not happy with him, he fled to *Utyusha* in Southern part of Tiv society. Two men known for their bravery and strength, *Kpamberakpa* and *Anyamazenga* were sent to bring him back. When they got there and caught him, instead of bringing him back, they killed him. Before his death, he sought for permission to prepare, *wuha Swem*. He was given, and he took a small pot, filled it with ashes, *gbaaye*, 'iron wood', *ayande* and *ijembeaondo*. After a few days, they killed Ikaragbe. When they returned, they fell ill and died. It was believed that *Swem* had killed them. This is while the Tiv consider *Swem* as a sacred weapon against injustice.

### **Constituents of *Swem***

The primary constituents of *Swem* are the ashes of Tiv's head. In addition to the ashes is *gbaaye*, 'iron wood', *ayande* 'mystical plant', *ijembe aondo* 'axe of God', *wua* 'guinea corn', *inya* 'sand' *ingyur* 'feathers', *kor* 'camwood', *ityegh* 'pot' and or 'man' (Akwaki, 2006). *Gbaaye* (iron wood) represents strength (Moti & Wegh, 2001). *Wua* (guinea corn) represents foodstuff. *Ityegh* (pot) represents the microcosm of the microcosm, the universe. *Ayande* (mystical plant) represents peace and vegetation. It means the Tiv should live in peace and cultivate land. *Ijembeaondo* (axe of God) represents the wrath of God (Akwaki, 2006). The axe belongs to God and falls on the disobedient. When all these items are linked together, they summon the spirits of both the living and the dead. It captures the symbol of totality of Tiv society and culture in all sacredness, a pictorial representation of Tiv collective spirit.

### **The Place of *Swem* in the Enforcement of Justice in Tiv Society**

According to Tiv worldview, the universe was made by a just God who created the world and gave man the intermediaries, spirited beings – *ajov* as a guide for mastery. It is these intermediaries that manifest the power of God. As the Tiv practiced *tsav*, at a point it required the use of human sacrifice to appease the gods to repair the land. This led to the introduction of human sacrifice in Tiv culture. But after some time, the ritual degenerated to a vile level that individual witches and wizards started killing to acquire power and prestige. As individuals became powerful, *tsav* was abused as people unjustly attack their brothers (Akwaki, 2006). This made the elders to introduce *Swem* to curtail the trend. *Swem* being considered as *gbaaondo* justice was used to punish evil men and protect the just.

*Swem* is a witchcraft power of the community, *ityo* (patrilineage). When prepared, it summons the power of the entire community for the realization of justice. According to Moti and Wegh (2001:48), "not everyone can *wuha*, dress *Swem*. Only those who have been initiated into great *akombo*, cultic emblem, can do this. And it is *ityo* (patrilineage) who must decide to *wuha* (dress) and *hembe*, break *Swem* for a specific reason. If an individual persists in carrying out anti-social activities, he may sometimes be made to *bum Swem*, swear on *Swem*." When someone is made to *bum swem*, swear by *Swem*, he is asked to take up the pot, *Swem* with two hands, refer to the crime he is alleged to have committed saying: "if I have committed such an evil, *Swem* should catch me." Then he places the *Swem* on his feet, stomach and head. If the person is guilty, after few days it swells his stomach and kills him. *Swem* affects everyone



including the Tiv and non-Tiv, through the invocation of the elders (Moti & Wegh, 2001). *Swem* had respect for nobody except the just and responsible. It sustained fairness, communality, tranquility and harmony in Tiv society. Ushe (2007:47) affirmed this, "it instills in the people a great deal of the sense of justice which is exhibited in character and behavior." However, *Swem* was the last resort in seeking for justice.

### **The Effects of Modernity on *Swem***

With the imposition of the Western culture on the Tiv people, there was a shift in emphasis on traditional ideas to Western belief system. The intrusion helps the missionaries to plant Christianity on Tiv soil, therefore, eroding Tiv metaphysical beliefs and tenets in most communities. According to Anshi (2008), "the destruction of Tiv belief system, world view and philosophy, has affect drastically the ancient practice of *tsav* for the benefits of members of the society and the maintenance of justice."

Today, *Swem* which was the mystical power that enforced justice has lost its place in most Tiv communities. Most Tiv men and women today claim they are Christians and deem swearing on *Swem* as evil and ungodly. They, therefore, use the Bible in taking oath instead of *Swem* which has immediate consequences. This has led to a relegation of the practice of the *Swem* ritual to the background, therefore making the Tiv society vulnerable and overwhelmed by falsehood, deceit, greed, corruption and injustice.

### **The Significance of *Swem* in the Unity of the Tiv Society**

The Tiv teaches that man is a social being. He is connected with others in the society by nature. In the society, each person has the responsibility towards the other person. For the society to be peaceful, developmental and stable, everyone has responsibility to live a good and responsible life. This attitude is captured in the word, justice. Justice, for them, is a web which holds any society together (Otakpor, 1994). With justice, there is unity, peace, development, progress and order in the society. The society is the field within which everyone has to live and accomplish his or her ends. Accomplishment of one's pristine destiny depends wholly on one's participation in the activities of life and his involvement with others, as no one is considered indispensable. By activating one's relationship with others, the individual achieves true development.

Upon discovery that there were social vices in Tiv society that affected the ontological order of the society and the problem goes beyond *Igbe I duun*, and that human sacrifice is needed, the Tiv elders introduced the use of human sacrifice to repair the land. This was carried out by the *mbatsav*, witches and wizards, for the survival of the community. In line with Anshi and Akwaki (2006:20-21), when it was discovered that the *mbatsav* were killing not only for repairing the land but for their individual interests, power and prestige, the Tiv society therefore introduced *Swem* to regulate people's actions towards the good. Upon discovery of fact that *Swem* has the power to extract the truth in people and instill a great deal of a sense of justice in them which is exhibited in character and behavior, they used it to eliminate evil and wicked men who tried to hamper the development and progress of individuals and the society.

This was realized by the elders in summoning *Swem* to carry out justice. When it is summoned, a far-reaching decision is sealed by breaking the *Swem* to let loose the ancestral powers of against evil men and women that are perpetrating evil in the society. If it is an individual that has misbehaved and is denying, he or she is made to swear by *Swem* and break it. The death of the evil and unjust person served as a deterrent to other members of the community that have such tendencies. *Swem* therefore, sustained good behavior and made the society stable and progressive. It made Tiv people united and communalistic.

### **The Challenges of the Practice of *Swem* in Tiv Society Today**

The first thing we have to note here is that the Tiv did not only teach their people how to behave well, they used witchcraft, *Swem*, to enforce their belief in building a just society. With this, it was difficult to disrupt the relationship between man and the spirits of the universe that often cause disorder and malfunctioning of the entire cosmic nature and social equilibrium. This made the Tiv society to be orderly and cohesive. However, with the coming of the British Colonialists and the imposition of the capitalist system on the Tiv, there has been great damage done to the practice of using *Swem*, witchcraft, to enforce justice. Anshi (2008) affirmed this when he argued that "...the destruction of Tiv belief system, world view and philosophy has affected drastically, the ancient practice of *tsav* for the benefit of members of the society and the maintenance of justice."

Good behavior and consciousness of the welfare of the other in human relationship is in a way directly or indirectly still being emphasized but there is loss of the sense of community spirit in most Tiv communities and this has affected the effective use of *Swem* to enforce justice. What is often seen today is an abuse of the practice in the political arena, where unjust people unjustly break *Swem*. This does not mean, communities that have sustained the practice too does not effectively use *Swem* in enforcing justice, they do. But with the attack of the colonialists and the missionaries on the practice of *tsav*, most Tiv people have embraced the Western religious belief, Christianity, therefore considering most traditional practices as evil and ungodly. This has made the Bible, which does not unleash immediate consequences on the unjust, to take the place of *Swem* (Agundu, 2008). Today, due to the perpetual advancement of personal interest, injustice is celebrated in most Tiv communities instead of justice. The Tiv society has lost her order in most communities, therefore embracing injustice, sorcery, wickedness, greed, irresponsibility, envy and selfishness.

### **Conclusion**

We have established the fact that the practice of *Swem* features prominently and indispensably in the Tiv conception of justice. In Tiv society, living a just life was highly emphasized and any individual that violated the principle of justice was made to repair it with his life by swearing and breaking *Swem*, the Tiv mystical force that punished defaulters. This ensures fairness in the allocation of resources. As aforementioned, the study has looked at the definition of and origin of *swem* with emphasis made that *Swem* is *gbaaondo*. At the same time, the damaging and bastardizing effects of colonialism on the Tiv notion of justice has been pointed out, where we have shown clearly that *Swem* has been replaced by the Christian bible since most Tiv men and women today are Christians. This seems to make many Tiv communities to lose

the sense of community spirit. The common good of the community is no longer the pursuit of every member of the community, as individualism in the form of selfishness and greed have swallowed up the kind and altruistic thought of most people. Today, it is sad that justice which made the Tiv society united has been bastardized giving way to the celebration of injustice in most of their communities. Today, even though in a Westernized society, we can still strictly practice justice as obtainable in the pre-colonial times. It is appreciated that some Tiv communities are still doing well in this regard. They have integrated the Western system with the Tiv belief system without crisis. Just as *Swem* is used to enforce justice in some remote Tiv communities like Shangev-Ya, Agagbe, Ugbe in Kwande etc., *Swem* could still be used in the entire Tiv society to curtail the level of injustice and corruption in the land. It is sad that there is lack of fairness, equity, and community driven spirit in most communities. This is as a result of the relegation of the use of *Swem* to the background. We therefore sue for re-enactment of the practice of using *Swem* to enforce justice by all the communities in Tiv society. We have seen the harm done to Tiv society by the relegation of the traditional ideal of justice to the background, since there is no mystical force to enforce it, and it is clear that even though we cannot return to the pre-colonial times, we can still imbibe values and the traditional metaphysical belief of making people to swear on *swem* even when taking the oath of office, to enforce good governance and hurt injustice. This traditional seal must be restored since we have tried its abandonment and our society has been swallowed up by corruption. The elders understood the lukewarmness and recklessness of the African man and the place of the spirits in ensuring fairness in Tiv society, which was why they used the mystical force, *Swem*, to regulate human behavior towards perpetual goodness. A return to this practice is necessary to save the Tiv society from displacement and destruction. This regrettable deviation from tradition should serve as a lesson to other African societies that have abandoned their traditional ideals.

## References

- Akwaki, N. (2006). *Ghaaondo: An alternative for social justice reform in Nigeria*, M.A. Dissertation, Department of Religion and Philosophy, Benue State University Makurdi.
- Agundu, O. A. (2008). *Critical evaluation of the concept of justice among the Tiv*, Unpublished M.A. Seminar, Department of Philosophy, University of Nigeria Nsukka.
- Anshi, M. W. (2008). *Tie Cuning Faces of Tsav (Witchcraft) phenomenon in the maintenance of justice in Tiv society*, A Paper Presented at the International Conference on Philosophy and Law in Africa, University of Nigeria Nsukka.
- An introduction to Tie Philosophy*. Makurdi: Obeta Publishers.

The concept of the person in Tiv philosophy. In *Personhood and Personal Identity: A philosophical study*, Edited by Martin F. Asiegbu & Chidozie J. Chukwuokolo, Enugu: SNAAP Press Ltd.

Anyam, E. A. (2010). Man and his community in Tiv Beliefs, *African Journal of Local Societies Initiative*. (2010): 10-14.

Dzurgba, A. (2007). *On the Tiv of central Nigeria*, Ibadan: John Achters Limited.

Iyo, A. J. (1990). *Tiv nationalism and some aspects of British Rule 1954-1960*, Ph.D Thesis, Department of History, University of Calabar.

Moti, S. & Wegh, S. (2001). *An encounter between Tiv religion and Christianity*, Enugu: Snaap Press Ltd.

Otakpor, N. (1994). *A sense of justice," in rending in social and political philosophy. ed. FA. Adeigbo*, Ibadan: Claverianum Press.

Tseayo, I. J. (1975). *Conflict and incorporation in Nigeria: The integration of the Tiv*. Zaria: Gaskiya Corporation Ltd.

Ushe, M. U. (2007). *Kpor of Tiv culture*, Enugu: SAN Press Ltd.

